

RAFNA R-450 RAILGEAR

2017 and Up Ford F-450/550 CC

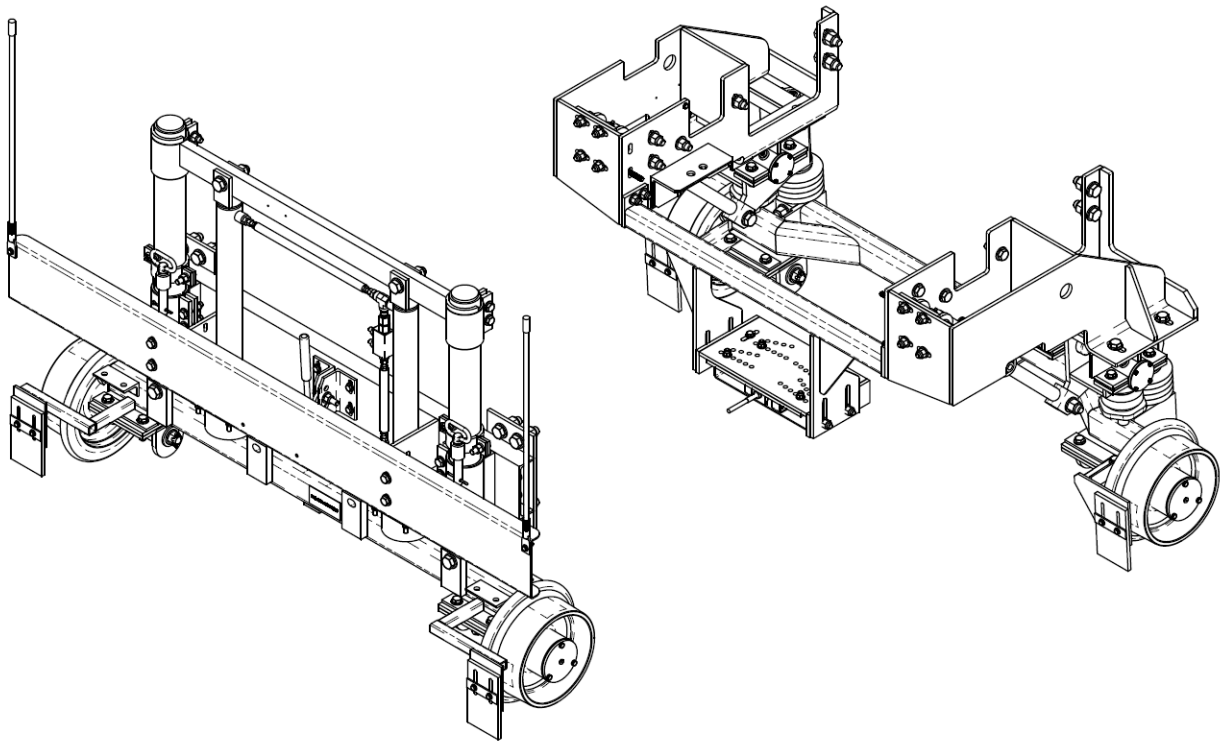

INSTALLATION / OPERATIONS / SERVICE MANUAL

THIS PAGE INTENTIONALLY LEFT BLANK

Table of Contents
DESCRIPTION

SECTION	DESCRIPTION	Pg.
1.0	GENERAL RAILGEAR INFORMATION	7
	Safety Precautions.....	7
	General Railgear Information	9
	Limited Warranty	13
	Warranty Policies and Procedures For Installers and Customers.....	14
	Warranty Claim Form	16
	Technical Service Bulletins.....	18
2.0	FRONT MOUNTING KIT	21
	Installation Safety Precautions	21
	Installation of R-450 Front Mounting Kit	22
	Operation Safety Precautions.....	28
	Operation and Service of R-450 Front Mounting Kit	29
3.0	FRONT RAILGEAR KIT	31
	Installation Safety Precautions	31
	Front Railgear Kit.....	32
	Diesel Exhaust Modification (2017 Ford SD F-250 Thru F-450 & Chassis Cab)	38
	Operation Safety Precautions.....	41
	Operation of Vertical Front Railgear Kit	42
	Placing the Vehicle on Rail - To Lower the Railgear:.....	42
	Removing the Vehicle from Rail - To Raise the Railgear:	42
	Service of Vertical Front Railgear Kit.....	43
	Rail Wheel Bearing Adjustment.....	46
	Rail Sweep Adjustment	46
	Vehicle Front Tire Clearance Adjustment	47
	Railgear Lock System Adjustment	48
	Railgear Alignment	49
	Parts of Vertical Front Railgear Kit	53
	R-450 Pre-Delivery Checklist	60
4.0	AXLE LOCKUP KIT (ROD, CABLE, & HYDRAULIC)	63
	Installation Safety Precaution	63
	Installation of Rod Operated Front Axle Lock Kit	64
	Operation Safety Precautions.....	73
	Rod Operated Front Axle Lock Operation	74
	Rod Operated Front Axle Lock Adjustment	74
	Service of Rod Operated Axle Lock Kit	75
	Installation of Cable Operated Front Axle Lock Kit.....	76
	Operation Safety Precautions.....	85
	Cable Operated Front Axle Lock Operation.....	86
	Cable Operated Front Axle Lock Adjustment	86
	Service of Cable Operated Axle Lock Kit	87
	Installation of Hydraulic Operated Front Axle Lock Kit	88
	Operation Safety Precautions.....	96
	Hydraulic Front Axle Lock Operation	97
	Hydraulic Front Axle Lock-Up Adjustment	97
	Service of Hydraulic Front Axle Lock Kit	98
5.0	REAR RAILGEAR KIT	99

Installation Safety Precautions	99
Rear Railgear Kit	100
Installation of Rear Railgear Kit	101
Rear Lock-Up Cable Installation Procedure	104
Rear Lock-Up Lever Installation Procedure	105
Operation Safety Precautions	107
OPERATION OF ROTATING REAR RAILGEAR	108
Placing the Vehicle on Rail - To Lower the Railgear:	108
Removing the Vehicle from Rail - To Raise the Railgear:	108
SERVICE OF ROTATING REAR RAILGEAR	109
RAILGEAR OVER-CENTER ADJUSTMENT	112
RAIL WHEEL BEARING ADJUSTMENT	114
RAIL SWEEP ADJUSTMENT	114
RAIL WHEEL LOAD ADJUSTMENT	115
Check each rail wheel load as follows:	115
Adjust each rail wheel load as follows:	116
RAILGEAR ALIGNMENT	118
RAILGEAR LOCK SYSTEM ADJUSTMENT PROCEDURE	121
6.0 HYDRAULIC KIT (HYDRAULIC PUMP & PTO)	141
Installation Safety Precautions	141
Installation of Hydraulic Kit w/ Pump	143
Operation/Service Safety Precautions	150
Operation of Hydraulic Kit (PUMP)	151
Location and Operation of the Railgear Hydraulic System Controls:	151
Service of Hydraulic Kit	152
Hydraulic System Relief Valve Setting	153
Electrical System Troubleshooting	154
Parts of Hydraulic Kit	155
Installation of Hydraulic for PTO Applications	157
Operation/Service Safety Precautions	160
Operation of Hydraulic Kit (PTO)	161
Location and Operation of the Railgear Hydraulic System Controls:	161
Service of Hydraulic Kit	162
Hydraulic System Relief Valve Setting	163
7.0 HYDRAULIC FRONT & REAR BRAKE KITS	165
Safety Precautions	165
Installation of Front Hydraulic Brake Kit	166
Installation of Rear Hydraulic Brake Kit (Optional)	171
Operation/Service Safety Precautions	176
Operation of Hydraulic Brake Kit	177
To Operate The Vehicle On Rail:	177
To Operate The Vehicle On Road:	177
Service of Hydraulic Brake Kit	178
Brake Shoe To Rail Wheel Clearance Adjustment	179
Hydraulic Brake Relief Valve Setting	180
Parts of Hydraulic Brake Kit	181
8.0 STEERING WHEEL LOCK	187
Safety Precautions	187
Installation Of Steering Wheel Lock	188
Operation Safety Precautions	191

Operation of Steering Wheel Lock	192
Service of Steering Wheel Lock.....	192
9.0 EMERGENCY HAND PUMP FOR PTO APPLICATIONS	193
Installation Of Emergency Hand Pump.....	194
Emergency Hand Pump Operation.....	198
10.0 VERTICAL FRONT MANUAL LOCK KIT	201
Installation Safety Precautions	201
Installation of Front Railgear Manual Lock Kit.....	202
Operation & Service Safety Precautions.....	205
Operation of Front Railgear Manual Lock Kit	206
To Engage Manual Lock:	206
To Disengage Manual Lock:.....	206
Service of Front Railgear Manual Lock Kit	207
11.0 RAILGEAR KITS/PARTS LISTS	209
NOTES	219

RAFNA "CUSHION-RIDE" RAILGEAR

**OPERATION, SERVICE AND
PARTS MANUALS
&
INSTALLATION MANUALS**

**READ THESE MANUALS BEFORE
INSTALLING THE RAILGEAR EQUIPMENT
AND/OR BEFORE OPERATING THE
RAILGEAR EQUIPPED VEHICLE**

**THIS SET OF MANUALS IS FOR RAILGEAR
SERIAL NUMBERS:**

_____ & _____

1.0 GENERAL RAILGEAR INFORMATION

SAFETY PRECAUTIONS

If any problems are encountered, please call G&B Specialties, Inc. for technical assistance.



- Failure to heed to any of the following warnings could result in severe bodily injury and/or equipment damage.
- Read and understand all manuals completely before attempting operation of the railgear equipped vehicle or service or installation of the railgear.
- Generic instructions provided below only address RAFNA railgear equipment. Applicable railway company procedures and policies must be adhered to.
- Ensure that the position and function of all railgear controls are known before attempting operation.
- Railway company rules governing rail travel must be observed at all times.
- Rail travel speed should always be in conformance with railway company regulations and should be reduced during inclement weather, passing through road crossings, switches, frogs, bridges, and curves. Curves of greater than 20 degrees should be negotiated with extreme caution. Operation of this vehicle at unsafe speeds could result in derailment.
- Ensure the railgear is locked in road or rail position before starting road or rail travel respectively.
- This vehicle will not operate crossing signals. At level crossings, ensure that no other vehicles are approaching and flag the crossing to ensure safety. Use caution when approaching and traversing level crossings.
- Never operate the vehicle if the Gross Vehicle Weight Rating (GVWR), Gross Axle Weight Rating Front or Rear (GAWR), or the wheel or tire load ratings are exceeded.
- Before performing any work under the vehicle or railgear, ensure the engine is turned off and the parking brake is set.
- Ensure all body parts and loose clothing are clear of any moving parts of the equipment.

- If misalignment of the railgear equipment is indicated, promptly perform the alignment procedure. Note that excessively worn rail wheels, vehicle pulling to one side while on rail, and vibration through the vehicle while on rail are indicators of railgear misalignment.
- Following the first 100 km (62 miles) of combined road and rail travel, the vehicle road wheel and spacer lug nuts should be re-torqued as per the Road Wheels and Tires Kit Operation, Service, and Parts manual if applicable.
- On newly installed railgear, following the first eight (8) hours of rail travel, inspect the rail wheel bearing end-play as per the Railgear Kit Operation, Service, and Parts manual. During this time, the bearings will have seated and may require adjustment of end-play. If the end-play is not in accordance with specifications, bearing failure could occur and would not be covered under warranty. Also check for sufficient grease in the wheel bearings.
- If the vehicle was derailed or involved in an accident, a thorough inspection of the complete railgear package for damaged parts should be carried out before the vehicle is put back in service.

GENERAL RAILGEAR INFORMATION

The RAFNA railgear is a hydraulically operated road-to-rail conversion system. The front and rear railgear are mounted to the vehicle frame and hydraulically raise and lowered via a 12 VDC electric hydraulic pump or an alternative hydraulic pump (e.g. PTO driven pump). During road travel, the front and rear railgear are mechanically locked in the road position. During rail travel, the front and rear railgear are locked in rail position via hydraulic check valves or mechanical locks, depending on model. A steering wheel lock keeps the vehicle front wheels straight during rail travel. The railgear’s spring suspension system ensures constant rail wheel to rail contact and a comfortable ride. Propulsion and braking on rail are provided by the vehicle original systems through the vehicle’s wheels contact with the rail. Additional on rail braking may be provided by an optional rail wheel brake package.

The RAFNA railgear is supplied with a group of Operation, Service, and Part Manuals and Installation Manuals which are specific to the railgear, mounting, hydraulic, wheel, steering wheel lock, and/or other or optional kits ordered. As a group, the manuals provide all the information relative to the particular railgear package. The group of manuals may not be interchangeable with other railgear equipped vehicles due to different options and/or applications. If replacement manuals need to be ordered, the railgear serial number and/or the kit numbers must be provided to G&B Specialties.

All the manuals should be read in their entirety before any installation or operation is attempted. This will ensure that all the information is covered.

All manuals use the “Driver’s Seat” orientation convention. All directions, i.e. right, left, front and back, are from sitting in the driver’s seat of the vehicle.

The railgear serial numbers, model numbers, and dates of manufacture for both the front and rear railgear should be recorded below for future reference. This information is stamped on the railgear identification plate riveted to each railgear.

	Front Railgear Info	Rear Railgear Info
Serial Number:	_____	_____
Model Number:	_____	_____
Date of Manufacture:	_____	_____

TECHNICAL SERVICE BULLETINS

Any changes and/or additional procedures that are issued for this equipment can be found in the G&B Specialties Technical Service Bulletins. These technical service bulletins are available on the RAFNA web site (www.rafna.com) as well as from G&B Specialties directly.

GENERAL INSTALLATION INFORMATION

The installation procedure consists of installing various supplied kits. Each kit is supplied with an Installation Manual as well as an Operation, Service and Parts Manual. Consult the respective kit manuals for installation instructions. The kits should be installed in the following order, as applicable:

- Road Wheels & Tires Kit
- Steering Wheel Lock Kit
- Front & Rear Mounting Kits
- Front & Rear Railgear Kits
- Front Axle Lock-up Kit
- Hydraulics Kit
- Rail Wheel Brakes Kit
- Option Kits

Ensure the serial numbers on the railgear on the vehicle match the serial numbers on this set of manuals and then ensure this entire set of manuals is given to the operator upon delivery of the vehicle.

GENERAL OPERATION INFORMATION

The following are only general operation instructions. For detailed operation instructions, consult the Operation, Service and Parts Manual provided with each individual kit.

Placing the Vehicle on Rail - General Info:

1. Prior to using the railgear equipment the following items should be inspected:
 - Inspect the condition of steel or rubber tread rail wheels if applicable
 - Check for damaged or worn parts
 - Check for loose wheels and/or fasteners
 - Check for leaking or damaged hydraulic hoses, fittings, cylinders, etc.
 - Check for leaking or damaged air brake hoses, fittings, chambers, etc. if applicable
 - Check for proper lubrication at the specified intervals
 - Ensure the vehicle is in good operating condition as per the manufacturer's operating guide
2. At a level crossing, reverse the vehicle onto and parallel to the rails so that the rear railgear rail wheels are aligned directly over the rails and the front railgear rail wheels are somewhat aligned with the rails.
3. Deploy the rear railgear as per the Railgear Kit Operation, Service, and Parts manual.

4. Reverse the vehicle until the front railgear rail wheels are aligned with the rails.
5. Deploy the front railgear and front axle lock-up (if applicable) as per the Railgear Kit and Front Axle Lock-up Kit Operation, Service and Parts manuals.
6. If applicable, turn on the rail wheel brake system as per the Rail Wheel Brake Kit Operation, Service, and Parts manual.
7. Engage the steering wheel lock as per the Steering Wheel Lock Kit Operation, Service and Parts manual.

Driving the Vehicle on Rail - General Info:

Before and while driving the vehicle on rail, the following general guidelines, as well as those in all the Operation, Service and Parts manuals, must be followed.

1. The vehicle may be driven on rail as normal however without steering and at reduced speeds.
2. Braking ability on rail is considerably reduced and the brakes must be applied gradually to avoid skidding the vehicle wheels.
3. Ensure that both the front and rear railgear are fully deployed.
4. Ensure that the railgear lock systems are engaged.
5. Ensure that the vehicle front axle lock-up is engaged if applicable.
6. Ensure that the steering wheel lock is engaged.
7. Ensure that the rail wheel brake system is turned on if applicable.
8. Ensure that the railgear hydraulic pump is turned off if applicable.

Removing the Vehicle from Rail - General Info:

1. Remove the vehicle from rail at a level crossing or other suitable location.
2. Retract the front railgear and front axle lock-up (if applicable) as per the Railgear Kit and Front Axle Lock-up Kit Operation, Service and Parts manuals.
3. Retract the rear railgear as per the Railgear Kit Operation, Service and Parts manual.
4. Turn off the rail wheel brake system as per the Rail Wheel Brake Kit Operation, Service and Parts manual.
5. Disengage the steering wheel lock as per the Steering Wheel Lock Kit Operation, Service and Parts manual.
6. Drive the vehicle carefully off the rails and onto the road.

GENERAL SERVICE INFORMATION

If any technical service issues arise, please contact the G&B Specialties, Inc. Also, please find attached the G&B Specialties Limited Warranty policy and procedures.

GENERAL PARTS INFORMATION

For general parts orders, please contact the G&B Specialties, Inc.

G&B Specialties, Inc.

LIMITED WARRANTY

G&B Specialties warranty covers a period of TWELVE (12) months after the date of the railgear's entry into service. This warranty applies to the Railgear itself, along with the hydraulic pump/motor assembly provided with our R-450 Railgear. The warranty asserts that each new railgear sold will be free from defects in material and workmanship under normal use and service. G&B Specialties' obligation under this warranty is limited to repairing or replacing at its factory, or other locations as designated by the company. Any defective part or parts must be returned within 30 days of the date of failure or notice of defect for factory inspection or as designated by G&B Specialties, Inc.

Equipment or parts not manufactured by G&B Specialties, but which are furnished in connection with G&B Specialties products are covered directly and solely by the warranty of the original equipment manufacturer supplying them.

The obligation of G&B Specialties under this warranty is limited to the replacement of parts that appear to be defective after review and inspection by our firm or designated representative. This warranty does not oblige G&B Specialties to bear the Customer's cost of labor or transportation charges concerning the return of defective parts. However, if found to be defective the outbound direct ground freight on the part will be prepaid to locations within continental United States and Canada by G&B Specialties, Inc. The warranty does not cover normal wear parts such as rail wheels, guide tubes, bearings, seals, rail sweeps or responsibility for customer's claims arising from abuse, misuse, neglect, or alteration of the railgear. All claims are subject to inspection of said parts by our firm.

This warranty is in lieu of other warranties, expressed or implied, including any implied warranties of merchantability or fitness for a particular purpose and any liability for special or consequential damages.

PRODUCT IMPROVEMENT LIABILITY DISCLAIMER

G&B Specialties, Inc. reserves the right to make any changes in or improvements on its products without incurring any liability or obligation whatever and without being required to make any corresponding changes or improvements in products previously manufactured or sold.

IMPORTANT NOTICE

This warranty will be considered void if G&B Specialties Installation instructions or Service and Maintenance schedule is not followed according to the detailed instructions contained in both our Installation Manual and our Operation and Service Manual.

Rev. date: 8/31/07

WARRANTY POLICIES AND PROCEDURES FOR INSTALLERS AND CUSTOMERS

Installers & Customer Warranty:

To prevent unnecessary delays or misunderstandings in handling Installers' or Customers' warranty claims, it is required that all warranty requests be authorized prior to any repairs, modifications or adjustments being started.

Warranty information and authorization can be obtained from G&B Specialties.

G&B Specialties' warranty will not apply if the railgear or any of its components have been modified or replaced without the written consent of the company.

Additional Billing, Installers & Customers:

If during installation, it is found that incorrect parts have been shipped, G&B Specialties will cover all costs involved in replacing these parts and return of incorrectly shipped parts.

All warranty claims concerning short / incorrect shipment of parts or accessories must be made within 30 days of delivery.

To maintain control over extra or additional billing due to incorrect shipments, only the Engineering Manager or Customer Service Manager can issue a Purchase Order authorizing replacement parts, shipping, or work to be performed by an outside source.

Warranty Claim information and requirements:

G&B Specialties will require the following information at time of claim as well as the properly filled out "Warranty Claim Form" reference "Warranty Form v#2 04/01"

- Information Required:
- 1) Customer Purchase Order number.
 - 2) G&B Specialties railgear serial number.
 - 3) Vehicle unit number.
 - 4) Vehicle VIN number.
 - 5) Purchaser of G&B Specialties railgear.
 - 6) Date of purchase.
 - 7) Name of end user.
 - 8) Company requesting warranty claim.
 - 9) Ship to Address.
 - 10) Bill to Address.

On approval of warranty claim, and where return of parts is requested by G&B Specialties, the Installer or Customer will issue a Purchase Order to G&B Specialties, Inc. to cover the defective parts and out bound freight for part values exceeding \$50.00 US and \$75.00 CDN. G&B Specialties will in turn ship all required parts pre-paid ground direct to the Installer or Customer. On receipt of claimed warranty parts, G&B Specialties or their sub supplier will inspect defective parts and if deemed warranty, a credit will be issued to the Installer or Customer. If claimed warranty parts are not received within 30 days, a credit will not be issued.

Labor Warranty and /or additional labor charges:

Either the G&B Specialties Warranty or any of G&B Specialties sub-suppliers does not cover labor or additional labor charges such as travel.

Faulty Railgear Installations:

If a warranty claim arises due to incorrect installation by an installer who has not followed the written instructions as outlined in our manual or as trained by either G&B Specialties Customer Service or Sales Department, warranty claims will not be honored.

Parts Warranty:

G&B Specialties manufactured parts will be warranted and replaced if found to be defective due to poor materials or workmanship for up to one year from date of the railgear's entry into service. Parts not manufactured by G&B Specialties Inc. will be covered by the Original Equipment Manufacturer's warranty. Based on the OEM's investigation of the warranty claim against their manufactured component their decision will stand.

WARRANTY CLAIM FORM

This form must be completed prior to starting any warranty work

Warranty #

Customer			Date
Tel/Fax			Railgear S/N
Vehicle No.			Vehicle VIN
End User			Date of Purchase
P.O. Number			Ref #
Inv. Address			Ship to Address
Inv. Address			Ship to Address
Inv. Address			Ship to Address
Inv. Address			Ship to Address

Shipping instructions:
Shipper:

Standard Ground	Special Air
----------------------------	------------------------

Standard 5 days +	Select 3 days	Expedition 2-3 day	Express 2 days
------------------------------	------------------	-----------------------	-------------------

Way Bill #

PART No.	QUANTITY	DESCRIPTION

PROBLEM DESCRIPTION

Required Documentation from the Customer (For issuing Credit)

Description of G&B Specialties Parts (Ordered or Used)	Invoice #	Total Claimed \$	US/CAD

G&B SPECIALTIES approved by: _____ DATE: _____

CUSTOMER'S REPRESENTATIVE: _____ DATE: _____

THIS PAGE INTENTIONALLY LEFT BLANK



**CAUTION
WARNING**

**PLEASE READ ALL OF THE
FOLLOWING TSBs & BULLETINS
PRIOR TO INSTALLATION**

TECHNICAL REFERENCE BULLETIN RAFNA RAILGEAR	
ISSUE DATE: 6/23/14	TRB NUMBER: TRB-062314
HAZARD / URGENCY RATING	
X	DANGER - Physical harm is possible if TSB is not observed or followed
X	WARNING - Equipment damage is possible if TSB is not observed or followed
X	CAUTION - Essential issue affecting operation, service, parts or installation
X	INFORMATIONAL - Advisory which may be of interest

APPLICABLE EQUIPMENT:

ALL RAFNA RAIL GEAR MODELS

SUMMARY:

UNCONTROLLED RE-USE OF RAILGEAR HARDWARE

IMPACT:

EXCESSIVE REUSE OF ASSEMBLY/INSTALLATION HARDWARE CAN CAUSE THE HARDWARE TO LOOSEN AND OR FAIL UNDER CERTAIN CIRCUMSTANCES.

ACTION:

<p>ANY NYLOCK NUT THAT IS REMOVED FROM ANY PART OR COMPONENT OF ANY RAFNA RAILGEAR UNIT, FOR ANY REASON, IS TO BE REPLACED WITH A NEW, EQUIVALENT NYLOCK NUT. SUBSTITUTION OF THE ORIGINAL NUT IS NOT ACCEPTABLE.... i.e....A NYLOCK NUT IS TO BE REPLACED WITH AN EQUIVALENT NYLOCK NUT AND SUBSTITUTING ANY OTHER TYPE OF LOCK NUT IS NOT ACCEPTABLE.</p>

<p>ANY STOVER NUT (CROWN NUT, TOP LOCK NUT, DEFORMED THREAD NUT) THAT IS REMOVED FROM ANY PART OR COMPONENT OF ANY RAFNA RAILGEAR UNIT, FOR ANY REASON, IS TO BE REPLACED WITH A NEW, EQUIVALENT STOVER NUT (CROWN NUT, TOP LOCK NUT, DEFORMED THREAD NUT) ALONG WITH THE BOLT/SCREW BEING USED WITH THAT NUT. SUBSTITUTION OF THE ORIGINAL NUT IS NOT ACCEPTABLE.... i.e....A STOVER NUT IS TO BE REPLACED WITH AN EQUIVALENT STOVER NUT AND SUBSTITUTING ANY OTHER TYPE OF LOCK NUT IS NOT ACCEPTABLE.</p>

THIS PAGE INTENTIONALLY LEFT BLANK

2.0 FRONT MOUNTING KIT

INSTALLATION SAFETY PRECAUTIONS

If any installation problems are encountered, please call G&B Specialties for technical assistance before continuing with the installation process.



- Failure to heed to any of the following warnings could result in severe bodily injury and/or equipment damage.
- Read and understand this manual completely before attempting installation of the equipment.
- Installation instructions provided below only address the Rafna railgear equipment. Applicable railway company procedures and policies must be adhered to.
- Before performing any work under the vehicle or railgear, ensure the engine is turned off and the parking brake is set.
- Do not start the vehicle with the power steering hoses disconnected. Reconnect all hoses and secure the power steering cooler if the vehicle is started.
- Ensure all removed components are given to the vehicle owner after the installation of the railgear. These components must be re-installed if the railgear is removed from the vehicle.
- Always disconnect the vehicle's battery when welding on the vehicle or railgear to protect the vehicle's electrical system.
- Railway Company rules governing rail travel must be observed at all times.
- Never operate the vehicle if the Gross Vehicle Weight Rating (GVWR), Gross Axle Weight Rating Front or Rear (GAWR), or the wheel or tire load ratings are exceeded.

INSTALLATION OF R-450 FRONT MOUNTING KIT

The following procedure details the installation of the front mounting kit. The hardware required for this installation is listed in the table below.

K-M45VXFF017 Front Mounting Kit Installation Parts

Part Number	Description	Qty
R-33304D	Mounting Plate - Drivers Side	1
R-33306P	Mounting Plate - Passengers Side	1
R-33303D-A	Side Plate Assembly - Drivers Side	1
R-33305P-A	Side Plate Assembly - Passengers Side	1
R-33300	Frame Extension	2
R-33309	Spacer, Frame Extension	2
R-11114A	Tie Bar/Mounting Plate	1
R-990KIT-107A	5/8" UNC GR.8 Bolt x 7.00" Lg.	8
	5/8" UNC GR.8 Bolt x 2.00" Lg.	4
	5/8" Flat Washer, GR.8 - Type-A	24
	5/8" UNC GR.8 Nylon Insert Lock Nut	12
	7/8" UNC GR.8 Bolt x 7.00" Lg.	2
	7/8" Flat Washer, GR.8 - Type-A	4
	7/8" UNC GR.8 Nylon Insert Lock Nut	2

Frame Modification

1. Remove the front bumper and front tow hooks if so equipped. The bumper and tow hooks will be modified and re-installed.
2. Cut the tow hook flush with face of the mounting bracket and the inner mounting bracket ear 1" from center of welded nuts. (See Figure 1) This process is to be performed on both tow hooks, cutting only the inner ear off on each.
3. On the in-board side of the driver's side frame rail, remove the connector that is attached. (This will need to be relocated) Ream out the rear most hole location where the 7/8" bolt is to be used so that it may sit straight across when inserted through frame. (Figure 2 & 3)
4. On the out-board side of the passenger's side frame rail, drill through the existing hole for the 7/8" bolt. A 15/16" bit may be used to complete the through hole. (Figure 4)

Bracket Assembly

1. Place modified toe hook back in factory location and insert frame spacer into frame and fasten loosely with original hardware or supplied 65MM bolts and washers. Washers may need modified to ensure they sit flush with frame and will not be used if using the factory bolt.
2. Place R-33303D-A (Driver's Side Plate Assembly (Item 3)) flush on the inside face of the frame and flush with the bottom of the frame extension. Next place R-33304D (Driver's Side Mounting Plate (Item 1)) flush with the outside of the frame and flush with the bottom of R-33303D-A. Place frame extension spacer inside frame extension at the first of the three rear holes and fasten loosely with supplied 5/8" and 7/8" hardware. (Figure 5 & 6)
3. Repeat steps 1 and 2 on Passenger's side.
4. With Driver's side and Passenger's side brackets mounted loosely, insert R-11114A (Tie Bar Mounting Plate (Item 6)) into place and mount with supplied 5/8" hardware. (Figure 5 & 7)
5. Tighten all fasteners to required torque values.



Figure 1: Modification of Tow Hook (Driver's side shown)



Figure 2: Connector Location and 7/8" Bolt Hole

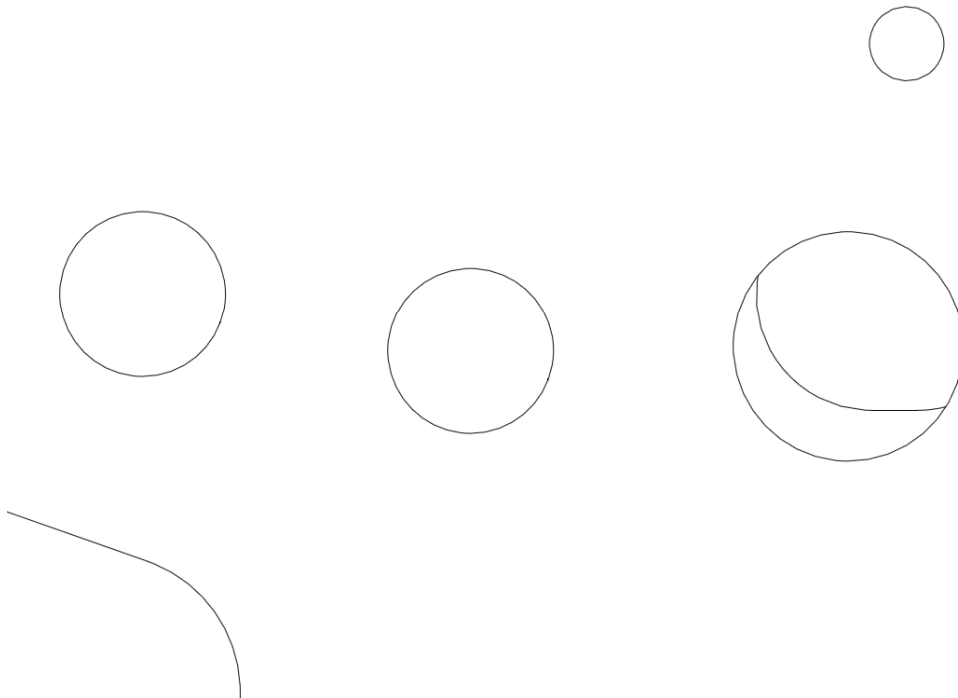

Figure 3: Outside Frame Looking through to Inside



Figure 4: Through Hole for 7/8" Bolt

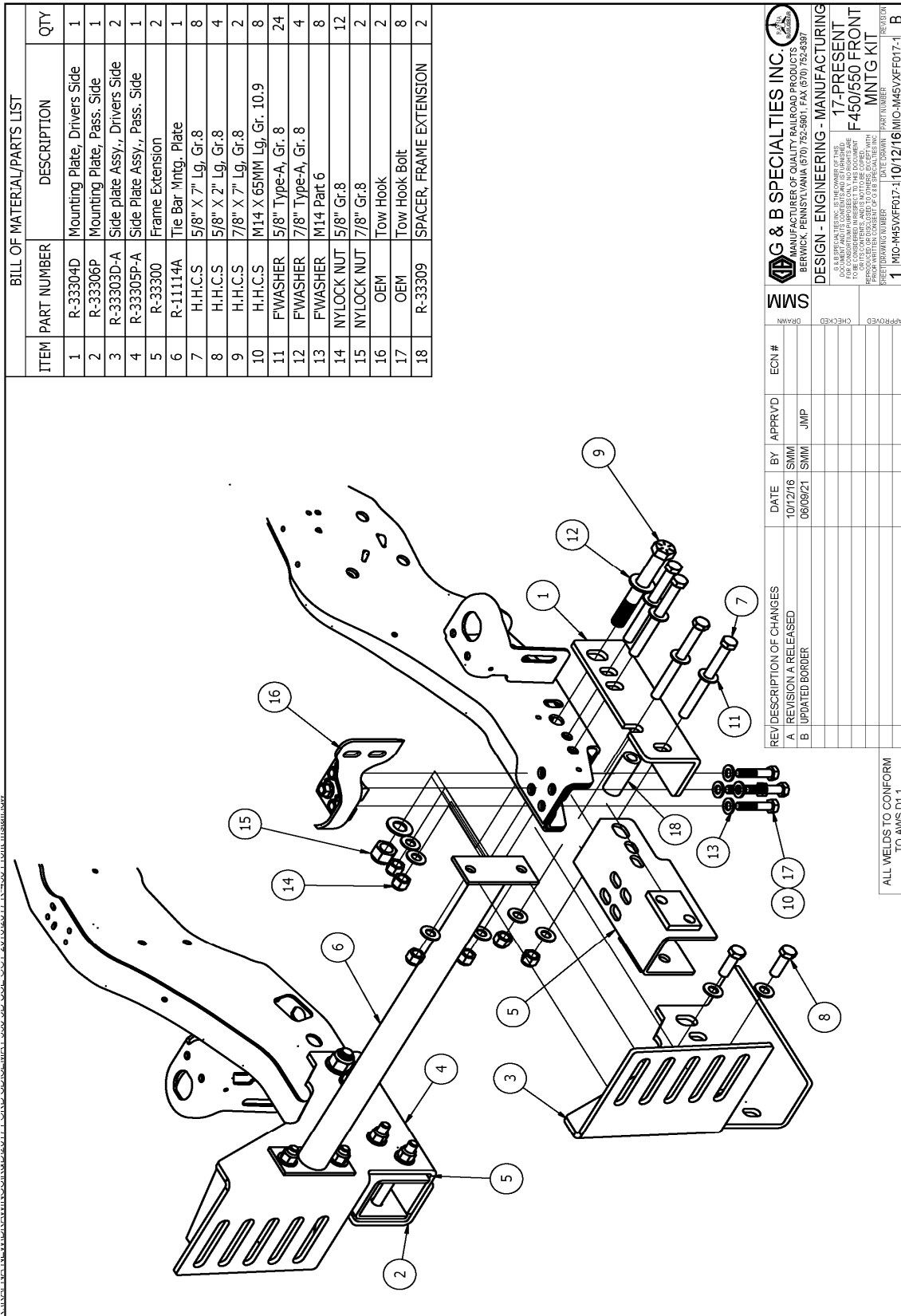

Figure 5: K-M45VXFF017 Exploded View



Figure 6: Mounted Brackets



Figure 7: Tie Bar Mounted

OPERATION SAFETY PRECAUTIONS

If any operating, services or parts problems are encountered, please call G&B Specialties Inc. for technical assistance.



- Failure to heed to any of the following warnings could result in severe bodily injury and/or equipment damage.
- Read and understand this manual completely before attempting installation of the equipment.
- Installation instructions provided below only address the RAFNA railgear equipment. Applicable railway company procedures and policies must be adhered to.
- Before performing any work under the vehicle or railgear, ensure the engine is turned off and the parking brake is set.
- Railway Company rules governing rail travel must be observed at all times.
- Never operate the vehicle if the Gross Vehicle Weight Rating (GVWR), Gross Axle Weight Rating Front or Rear (GAWR), or the wheel or tire load ratings are exceeded.

OPERATION AND SERVICE OF R-450 FRONT MOUNTING KIT

With the front mounting kit installed on this vehicle, it may be operated as normal, however the front bumper is located further forward than standard. Side wands are located on the front bumper to aid in determining the length and width of the vehicle. Caution must be used when operating the vehicle.

Never operate the vehicle if the Gross Vehicle Weight Rating (GVWR), Gross Axle Weight Rating Front or Rear (GAWR), or the wheel or tire load ratings are exceeded.

The front mounting kit must be serviced regularly to avoid damage to the equipment. Table 1 below provides the Recommended Service Schedule and Table 2 provides Standard Fastener Torque Values.

Table 1: Recommended Service Schedule

Service Required	Initial 100 km (62 Miles) of road and/or rail use	Daily	Weekly	Monthly
Inspect front mounting kit fasteners (re-torque if required)		✓	✓	✓

Table 2: Standard Fastener Torque Values

Fastener Size	Fastener Torque Value (ft.-lbs) Dry
1" UNC Gr. 8 Fasteners	250
7/8" UNC Gr. 8 Fasteners	200
3/4" UNC Gr. 8 Fasteners	175
5/8" UNC Gr. 8 Fasteners	150
1/2" UNC Gr. 8 Fasteners	100
3/8" UNC Gr. 8 Fasteners	40
1/4" UNC Gr. 8 Fasteners	12

THIS PAGE INTENTIONALLY LEFT BLANK

3.0 FRONT RAILGEAR KIT

INSTALLATION SAFETY PRECAUTIONS

If any installation problems are encountered, please call G&B Specialties, Inc. for technical assistance before continuing with the installation process.



- Failure to heed to any of the following warnings could result in severe bodily injury and/or equipment damage.
- Read and understand this manual completely before attempting installation of the equipment.
- Installation instructions provided below only address the RAFNA railgear equipment. Applicable railway company procedures and policies must be adhered to.
- Before performing any work under the vehicle or railgear, ensure that the engine is turned off and the parking brake is set.
- Beware of all pinch points on the railgear and keep all parts of the body clear.
- Always disconnect the vehicle's battery when welding on the vehicle or railgear in order to protect the vehicle's electrical system.
- Ensure all removed components are given to the vehicle owner after the installation of the railgear. These components must be re-installed if the railgear is removed from the vehicle.
- Railway Company rules governing rail travel must be observed at all times.
- Never operate the vehicle if the Gross Vehicle Weight Rating (GVWR), Gross Axle Weight Rating (GAWR), or the wheel or tire load ratings are exceeded.

FRONT RAILGEAR KIT

The following procedure details the installation of the front railgear kit. The hardware required for this installation is listed in the table below.

K-R45VXXR4531C Vertical Front Railgear Kit

Part Number	Description	Qty
R-4531AC	Vertical Front Railgear	1
R-001	10" Wheel Assembly	2
R-1000R	Rail Sweep, Driver's Side	1
R-1000L	Rail Sweep, Passenger's Side	1
R-051	Side Wand Set	1
R-2687AL	Front Bumper	1
R-4699	Front Bumper Support	2
R-4698	Collar	2
S-001031	Railgear Operation Decal	1
R-990KIT-204 (2 Kits)	1/2" UNC Gr.8 Bolt x 2.250" Long	8
	1/2" Gr.8 Washer	16
	1/2" UNC Gr.8 Nylon Insert Lock Nut	8
R-990KIT-024	3/4" UNC Gr.8 Bolt x 2.500" Long	8
	3/4" Gr.8 Washer	16
	3/4" UNC Gr.8 Nylon Insert Lock Nut	8

INSTALLATION OF FRONT RAILGEAR KIT

1. Ensure that the front mounting kit has been installed on the vehicle prior to installing the railgear kit.
2. In order to install the railgear at the correct height, ensure that the road wheels and tires kit has been installed on the vehicle and that the vehicle is resting on all of its properly inflated tires.
3. Position and support the railgear so that the mid-height mounting holes on the railgear align with the slots in the front mounting plates as shown. Center the railgear on the slots.
4. Fasten the railgear to the front mounting plates using four 3/4" bolts, eight 3/4" washers and four 3/4" nuts as shown. Tighten but do not torque the 3/4" fasteners as they will be torqued after the alignment procedure is completed.
5. Place the rail wheels below the mounting tables on the railgear axle. Place the rail sweeps in front of the rail wheels and on top of the mounting tables. Fasten the rail wheels and rail sweeps to the mounting tables with eight 1/2" x 2.25" long bolts, sixteen 1/2" washers and eight 1/2" nuts.
6. Tighten but do not torque the 1/2" fasteners as they will be torqued following the railgear alignment procedure.

Note:

Install the railgear hydraulic system as per the Hydraulic Kit Installation manual before continuing with the following steps.

7. Install the railgear operation decal near to the railgear hydraulic controls where it is clearly visible to the operator.
8. Follow the Vehicle Front Tire Clearance Adjustment procedure detailed in operations section of this manual.
9. Position the collars on the railgear outer tube so that they are tight against the top of the railgear upper cross frame clamps as shown. Weld the collars in place using 1/4" fillet welds on the top surface of the collars.
10. Follow the Railgear Alignment procedure detailed in operations section of this manual.
11. Fasten the hook to the hook supports using one 1/2" x 2.5" long bolt, two 1/2" washers and one 1/2" nut. Tighten but do not torque this 1/2" fastener, as the hook must be free to swing.
12. Support the front railgear in the road position. Align the hook supports on the railgear frame so that the hook will engage the latch. Ensure that the hooks can swing freely to engage and disengage.

13. Clamp the hook supports in place. Using the slots in the hook supports as templates, drill four 13/32" diameter holes in the railgear frame through the center of the slots. Fasten the hook supports to the railgear frame using four 3/8" x 1.25" long bolts, eight 3/8" washers and four 3/8" nuts. Torque the 3/8" fasteners to 40 ft-lbs dry. Do not over torque.
14. Follow the Railgear Lock System Adjustment Procedure detailed in operations section of this manual.
15. Fasten front bumper supports to the bumper provided in this kit using four 1/2" x 2.25" long bolts, eight 1/2" washers and four 1/2" nuts as shown. Torque the 1/2" fasteners to 100 ft-lbs dry. Do not over torque.
16. Align the front bumper supports with the front railgear cross channel. Weld the front bumper supports to the railgear cross channel using 1/4" fillet welds, both sides. Ensure that that the bumper does not obstruct the headlights.
17. Fasten the side wands to the front bumper with the supplied fasteners.
18. Follow the Rail Sweep Adjustment procedure detailed in operations section of this manual.
19. Torque all fasteners as detailed in operations section of this manual.
20. Grease the railgear at all lubrication points as detailed in operations section of this manual.
21. Paint any parts that were welded or heated.

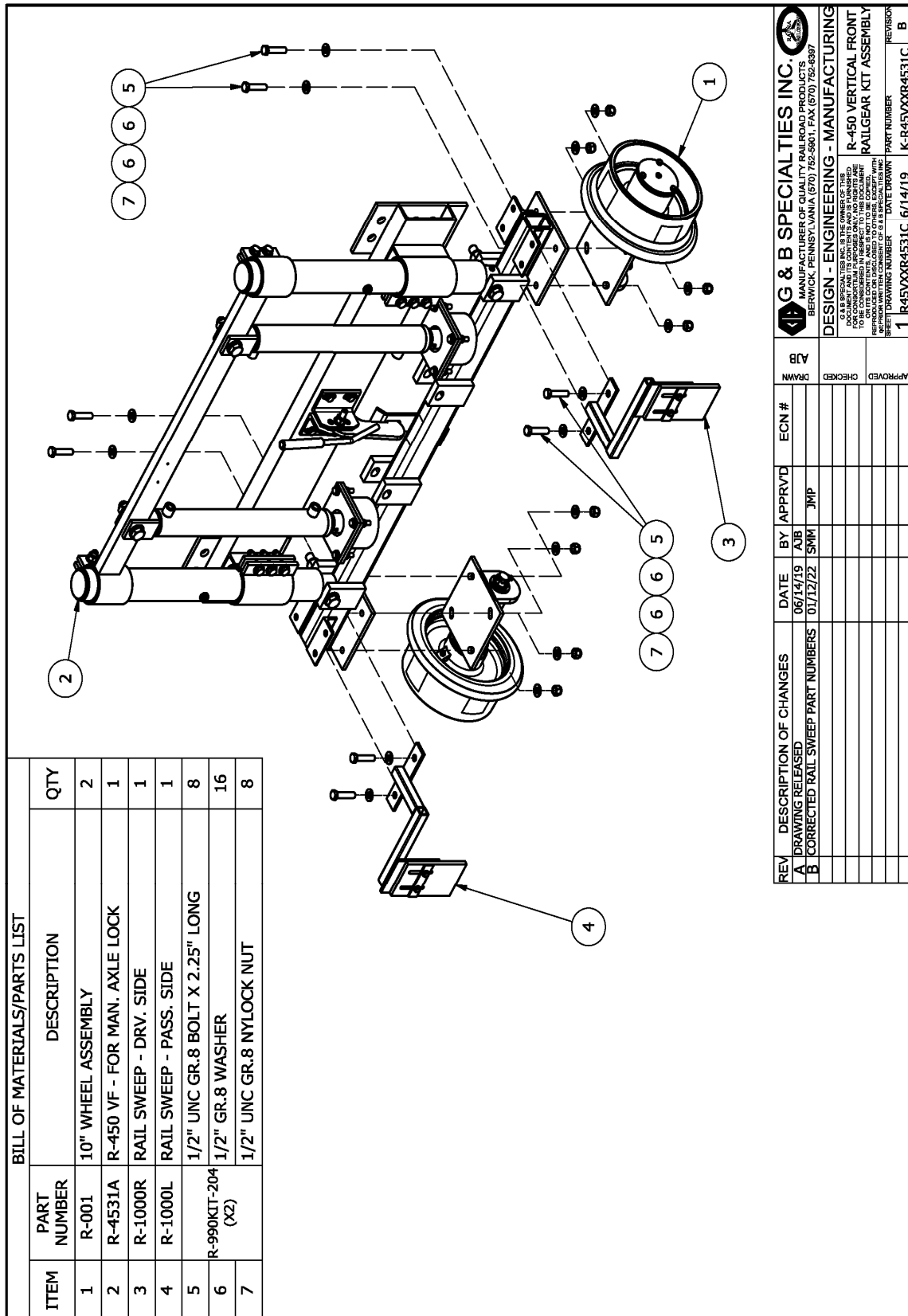

Figure 1

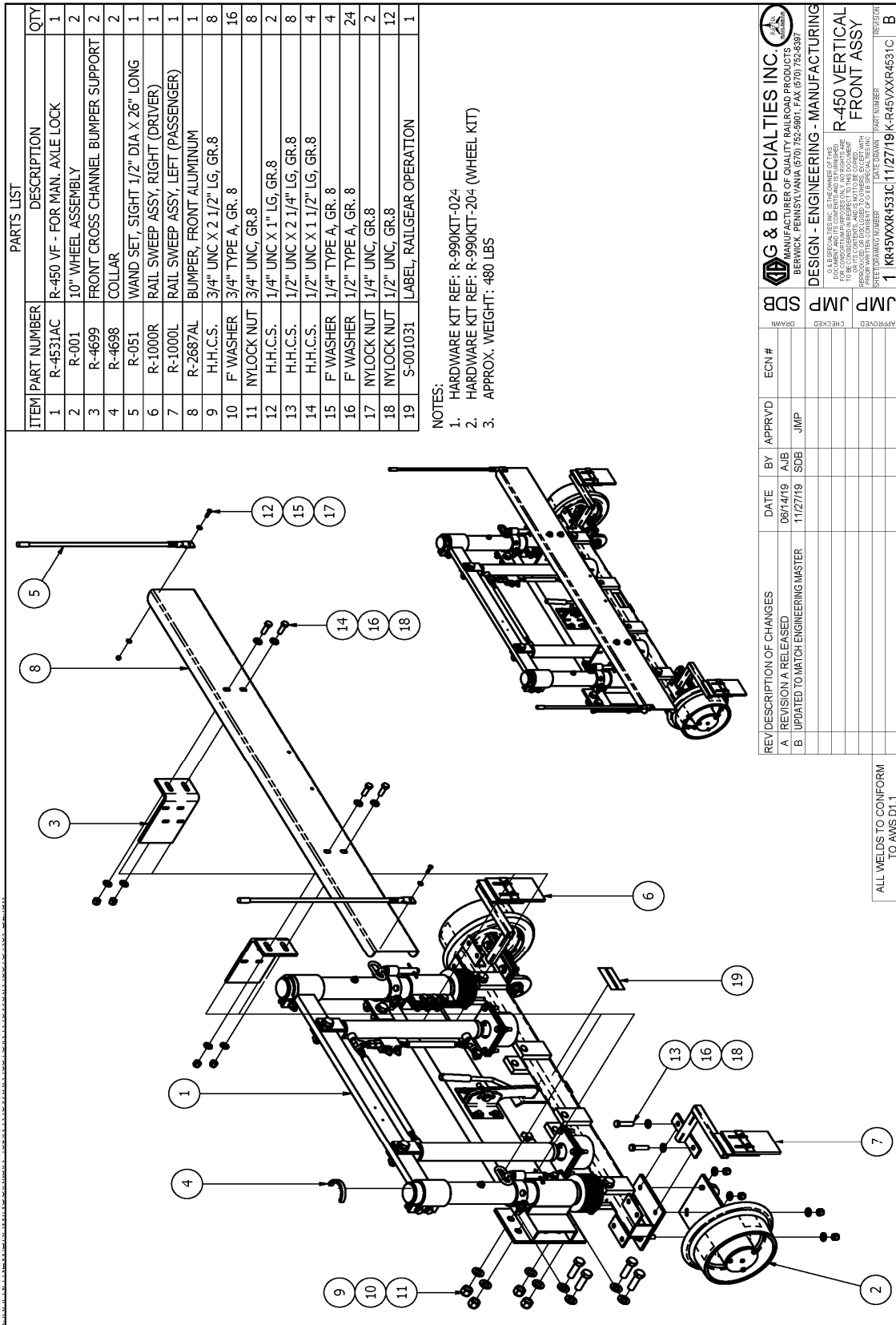

Figure 2

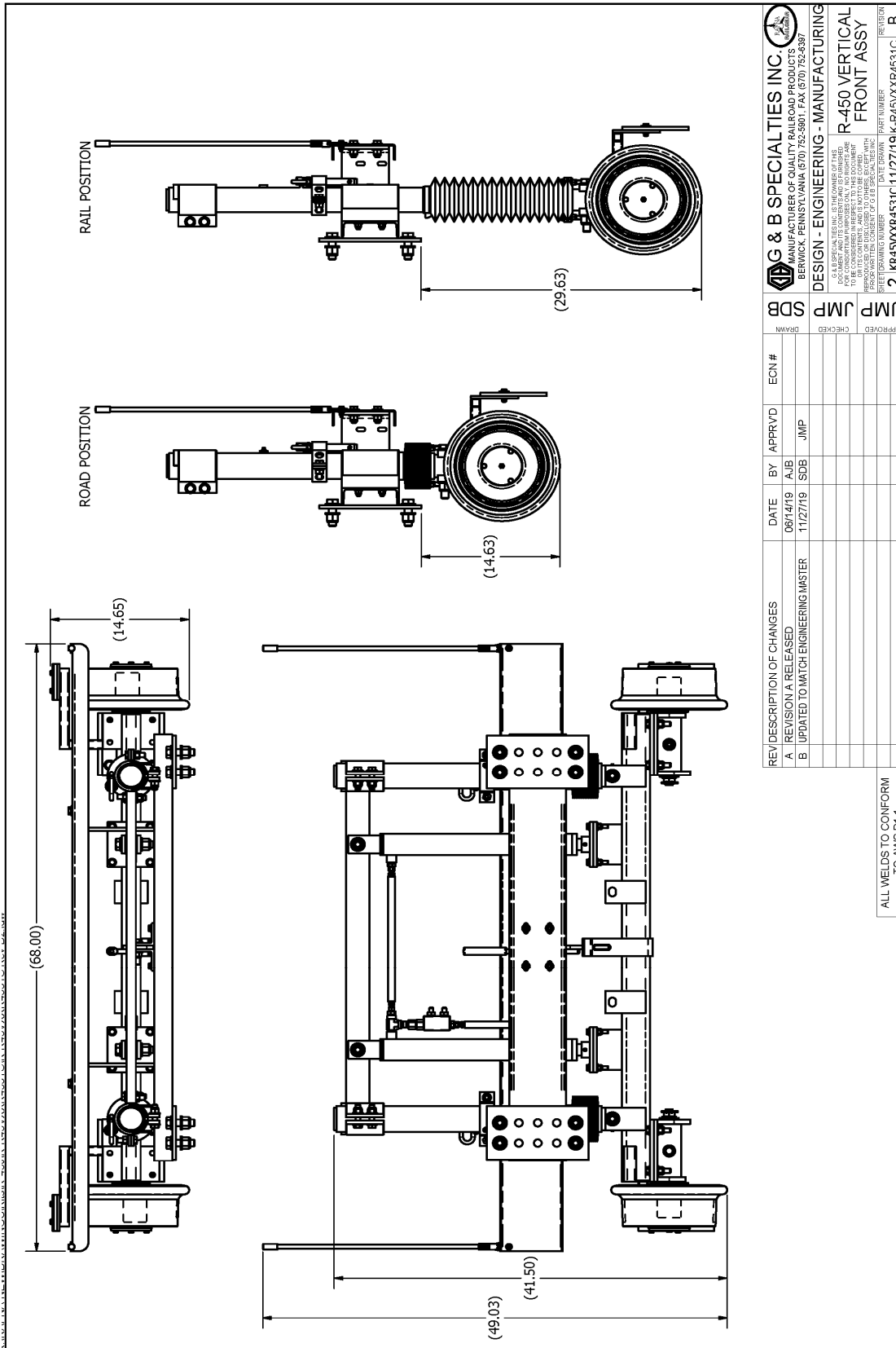

Figure 3

DIESEL EXHAUST MODIFICATION (2017 FORD SD F-250 THRU F-450 & CHASSIS CAB)

Applicable Installations:

R-290 Railgear installed on 2017 - CURRENT Ford F250/F350/F450/CHASSIS CAB, 6.7l *diesel* engines.

Recommendations:

Any alterations to the exhaust system of 2008 ~ 2010, Ford Super Duty F-Series, must follow the guidelines of Ford Document BBB0734-2007.

Any alterations to the exhaust system of 2011, Ford Super Duty F-Series, must follow the guidelines of Ford Document Q-187.



SVE BULLETIN

SPECIAL VEHICLE ENGINEERING – BODY BUILDERS ADVISORY SERVICE

E-Mail via Website: www.fleet.ford.com/truckbbas (click "Contact Us")

Toll-free: (877) 840-4338

QVM Bulletin: Q-253

Date: 09 August, 2016

2017 MY F-Series Super Duty 6.7L Exhaust System Modifications

Models Affected: 2017 MY to present F-Series Super Duty Pickup (F-250/350/450) and Chassis Cab with 6.7L diesel engine.

Description: Modifications to the exhaust system, when required to accommodate service body installations, may be made as shown:

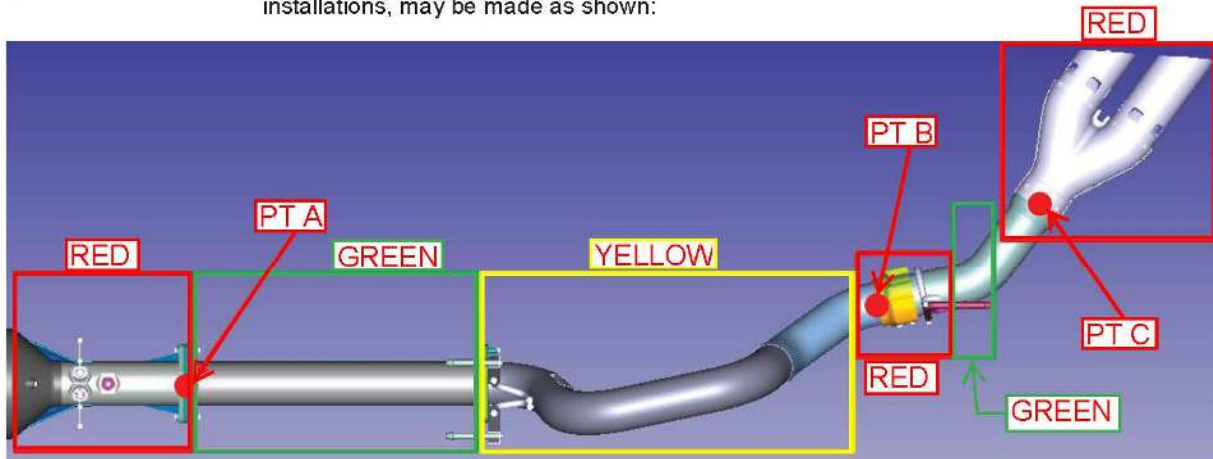

RED: Areas that CANNOT be modified due to durability or functional requirements.

YELLOW: Areas that are NOT RECOMMENDED for modification due to critical clearances to rear axle motion envelope.

GREEN: Areas that are allowed to be modified.

PT A - PT B: Any modifications between Pts A – B must not shorten the centerline length between the two points to a length less than that of the shortest wheelbase. MIN Centerline Length = 1160 mm for reference.

PT B – PT C: Any modifications between Pts B – C must not shorten the centerline length between the two points and should be made using pipe diameter equivalent to the OEM assembly. MIN Centerline Length = 400 mm for reference.

Additional information:

- Dual tip diffuser cannot be removed or altered.
- Modifications must not change system restriction or alter the performance of the dual tip diffuser (see following performance assessment recommendations).
- Appropriate heat shielding must be utilized if required.

Performance Assessment Recommendations:

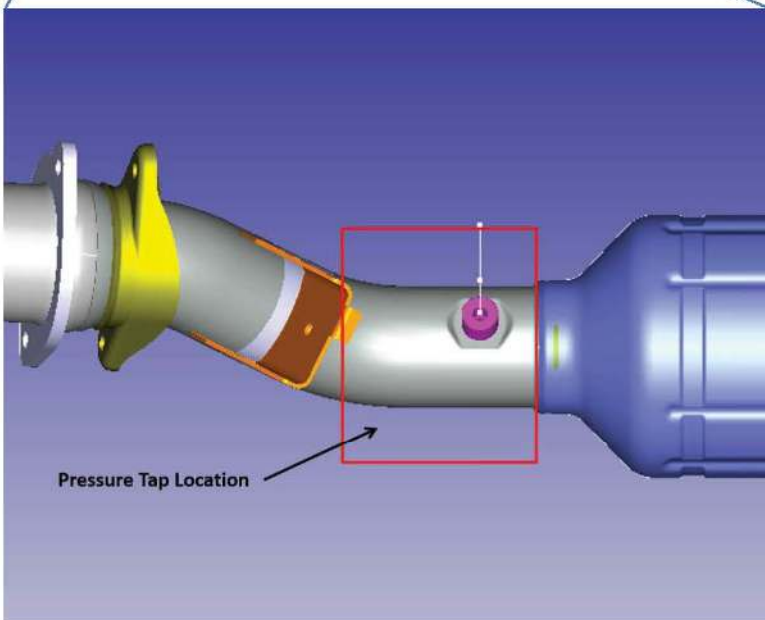
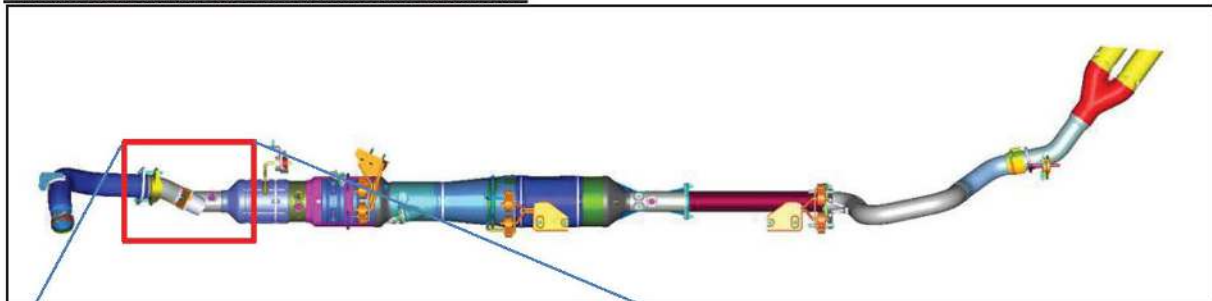

- Install a temporary pressure tap and suitable pressure measuring device upstream of the diesel oxidation catalyst
- Load vehicle and trailer to GVWR and operate the unit at WOT on a suitable grade.
- Record peak pressure reading.
- Repeat test following installation of aftermarket hardware to confirm equivalent pressure reading.
- Modify aftermarket hardware as required to achieve equivalent pressure readings.
- Modifications must not change backpressure (increase or decrease).

OPERATION SAFETY PRECAUTIONS

If any operating, services or parts problems are encountered, please call G&B Specialties, Inc. for technical assistance.



CAUTION
WARNING

- Failure to heed to any of the following warnings could result in severe bodily injury and/or equipment damage.
- Read and understand this manual completely before attempting operation of the railgear equipped vehicle.
- Operating instructions provided below only address the RAFNA railgear equipment. Applicable railway company procedures and policies must be adhered to.
- Railway company rules governing rail travel must be observed at all times.
- Ensure that the position and function of all railgear controls are known before attempting operation.
- Ensure the railgear is locked in road or rail position before starting road or rail travel respectively.
- Ensure all body parts and loose clothing are clear of any moving parts of the equipment.
- If misalignment of the railgear equipment is indicated, promptly perform the alignment procedure.
- Before performing any work under the vehicle or railgear, ensure the engine is turned off and the parking brake is set.
- Never operate the vehicle if the Gross Vehicle Weight Rating (GVWR), Gross Axle Weight Rating Front or Rear (GAWR), or the wheel or tire load ratings are exceeded.
- Always disconnect the vehicle's battery when welding on the vehicle or railgear in order to protect the vehicle's electrical system.

OPERATION OF VERTICAL FRONT RAILGEAR KIT

With the front railgear kit installed on this vehicle, it may be operated as normal, however the front bumper is located further forward than standard. Side wands are located on the front bumper to aid in determining the length and width of the vehicle. The vehicle has decreased ground clearance and angles of approach and departure due to the railgear. Caution must be used when operating the vehicle.

Never operate the vehicle if the Gross Vehicle Weight Rating (GVWR), Gross Axle Weight Rating Front or Rear (GAWR), or the wheel or tire load ratings are exceeded.

Refer to the Hydraulic Kit Operation, Service, and Parts manual for information on the location and operation of the railgear hydraulic system controls.

Placing the Vehicle on Rail - To Lower the Railgear:

1. Engage the vehicle front axle lock as per the Front Axle Lock Kit Operation, Service and Parts Manual.
2. Disengage the railgear lock hook by pushing the lock hook handle in towards the vehicle to the disengaged position. Do not force the handle. If the lock hook cannot be disengaged, raise the railgear slightly.
3. Hold the lock hook handle in the disengaged position.
4. Lower the railgear. Release the lock hook handle once the railgear has lowered past the road locked position.
5. As the railgear is being deployed, it will start taking the vehicle's load. (If this is not the case, **DO NOT use the railgear**. Inspect the railgear for lubrication and damage.)
6. Continue lowering the railgear until the hydraulic cylinders are fully extended. The vehicle front tires should be minimally 1.5" above the rail per AREMA Standards. (American Railway Engineering and Maintenance-of-Way Association, Maintenance-of-Way Work Equipment, AREMA Manual for Railway Engineering, 2006, Section 2.7.18, Point C) In colder operation locations and Railways that use switch heaters etc., 3" is suggested for ensured clearance of objects.
7. Ensure that the vehicle front axle lock is fully engaged.

Removing the Vehicle from Rail - To Raise the Railgear:

1. Raise the railgear fully. The railgear lock hook should engage automatically.
2. Ensure that the railgear lock hook is engaged and that the railgear is locked in the road position.
3. Disengage the vehicle front axle lock as per the Front Axle Lock Kit Operation, Service and Parts Manual.

SERVICE OF VERTICAL FRONT RAILGEAR KIT

The railgear kit must be serviced regularly to avoid damage to the equipment. Table 1 below provides the Recommended Service Schedule and the detailed service procedures follow.

Figure 1 provides the Non-Standard Fastener Torque Values. Table 2 provides Standard Fastener Torque Values for all other fasteners.

Grease fittings are provided at all railgear lubrication points as shown in Figure 2. The recommended lubricant for all lubrication points on this railgear is **MYSTIK JT-6 LOW TEMP** grease or equivalent. In cold weather areas/seasons, **SHELL DARINA XL102** or equivalent may be used.

Table 1: Recommended Service Schedule

Service Required	Daily	Weekly	Monthly	3 Months	6 Months	12 months
Visually inspect the railgear for damaged or worn parts	✓	✓	✓	✓	✓	
Check for loose rail wheels and fasteners (re-torque if required)	✓	✓	✓	✓	✓	
Ensure railgear lock pin is functioning correctly	✓	✓	✓	✓	✓	
Ensure the vehicle is in good operating condition	✓	✓	✓	✓	✓	
Inspect the rail wheel flanges for wear (use Rafna wear gauge)				✓	✓	
Inspect all hydraulic components for leaks or wear	✓	✓	✓	✓	✓	
Check and adjust rail sweeps			✓	✓	✓	
Grease railgear inner and outer guide tubes		✓	✓	✓	✓	
Grease railgear inner tube lower pivot point			✓	✓	✓	
Grease railgear locking pin			✓	✓	✓	
Check and adjust rail wheel bearing end-play			✓	✓	✓	
Grease rail wheel bearings (every 3000 rail kms or 1900 rail miles)				✓	✓	✓
Check and adjust rail wheel load						✓
Check and adjust rail wheel alignment						✓
Check and repack rail wheel bearings						✓
Check and adjust vehicle front tire clearance					✓	

Table 2: Standard Fastener Torque Values

Fastener Size	Fastener Torque Value (ft-lbs.) Dry
1" UNC GR.8 Fasteners	250
3/4" UNC GR.8 Fasteners	175
5/8" UNC GR.8 Fasteners	150
1/2" UNC GR.8 Fasteners	100
3/8" UNC GR.8 Fasteners	40
1/4" UNC GR.8 Fasteners	12

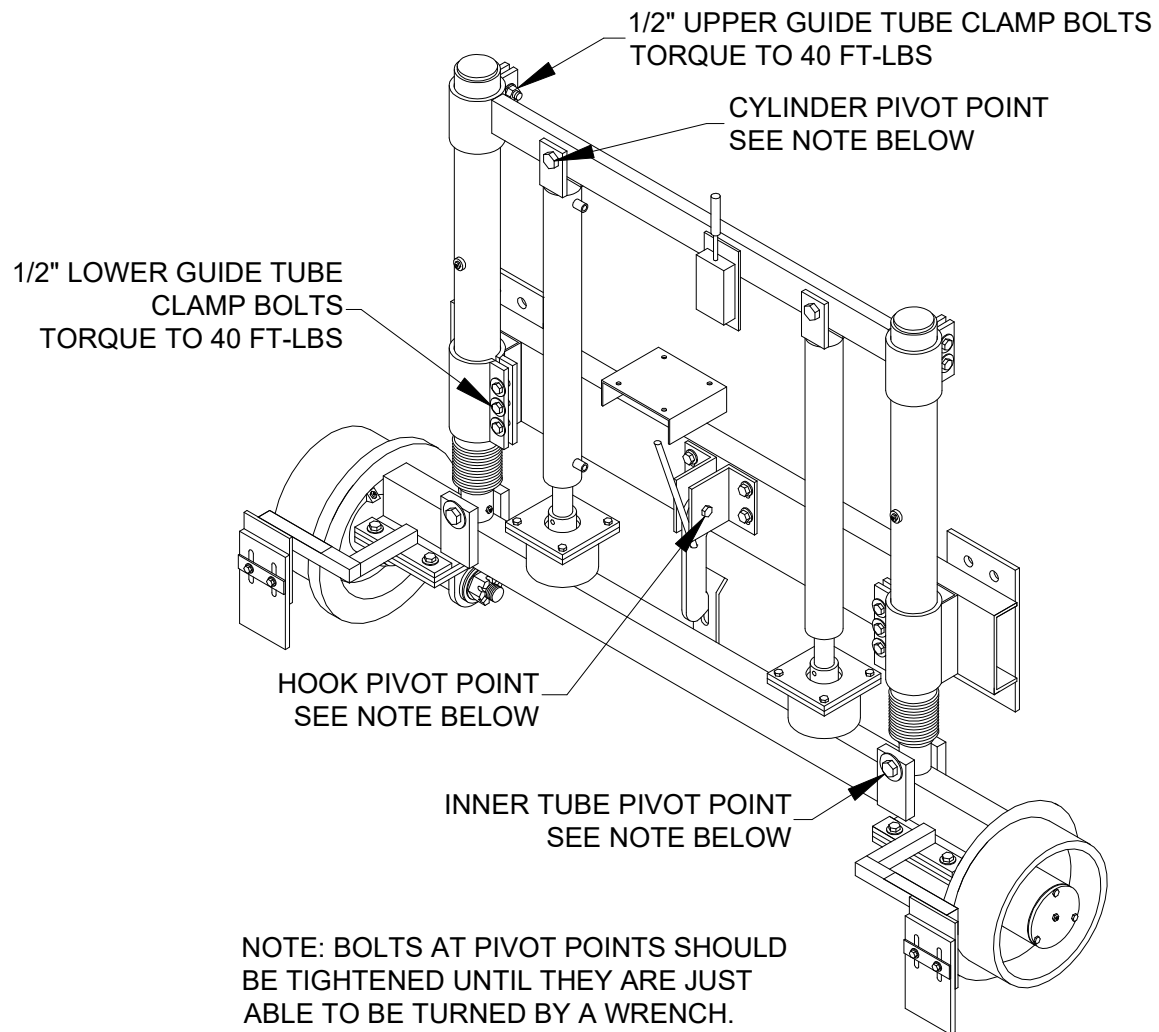

Figure 1. Non-Standard Fastener Torque Values

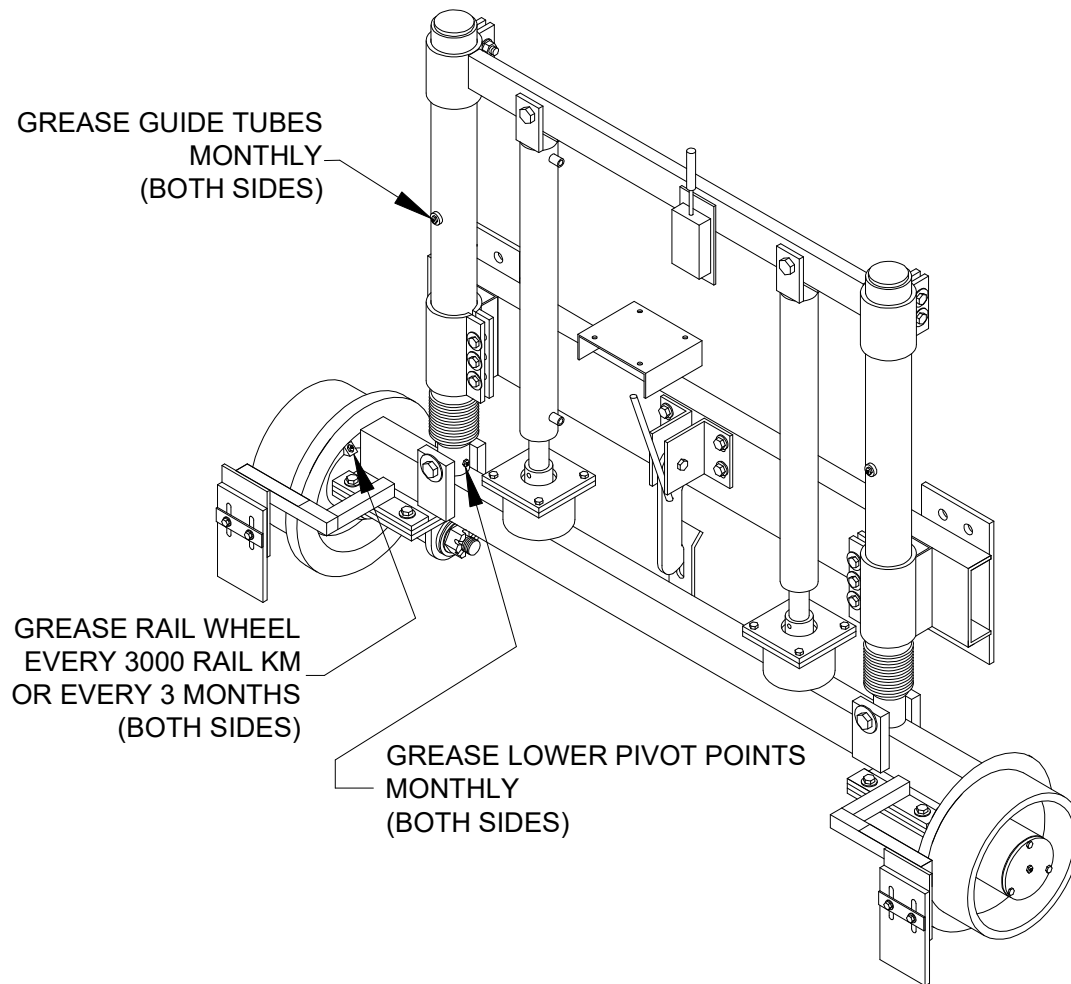

Figure 2. Railgear Lubrication Points

RAIL WHEEL BEARING ADJUSTMENT

The rail wheel bearings require periodic adjustment to keep the endplay within specification. If the rail wheel bearings are not correctly adjusted, failure may occur and will not be covered under the railgear warranty. Check and adjust the bearing endplay with the railgear in the road position and with the rail wheels free to turn.

Use a magnetic base dial gauge to measure the endplay of each rail wheel bearing. The bearing endplay must be between 0.001" and 0.005". If this is not the case, adjust as follows:

1. Remove the rail wheel hubcap and gasket by removing the three 1/4" bolts and 1/4" lock washers. Remove and discard the cotter pin from the 3/4" slotted spindle nut.
2. Ensure the wheel-bearing cavity is full of grease.
3. While rotating the rail wheel forward, torque the spindle nut to 20 ft-lbs. Then loosen the spindle nut and re-torque it to 6 ft-lbs. Re-check and re-adjust the bearing endplay if required. If no torque wrench is available, tighten the spindle nut until the rail wheel is difficult to turn by hand. Then loosen the spindle nut and retighten it just until no loose can be felt in the bearings. Re-adjust the bearing endplay with a torque wrench as soon as possible.
4. Install a new 3/16" x 2" long cotter pin through the spindle nut. Tighten the spindle nut slightly if needed to insert the cotter pin.
5. Re-install the hubcap and gasket using the 1/4" bolts and new 1/4" split lock washers. Blue Loctite can be used on the bolts as an added safety measure. Tighten and torque the 1/4" fasteners to 12 ft-lbs dry. Do not over torque.

RAIL SWEEP ADJUSTMENT

The distance between the rail sweep rubber and the rail is adjustable and should be maintained at approximately 1/8". To adjust the rail sweep rubber, with the railgear in the rail position, loosen the two 1/4" fasteners that secure the rail sweep rubber to the rail sweep bracket. Slide the rail sweep rubber up or down for the correct clearance. Tighten and torque the 1/4" fasteners to 12 ft-lbs dry. Do not over torque.

VEHICLE FRONT TIRE CLEARANCE ADJUSTMENT

The vehicle front tires must remain at a minimum height above the rail to ensure sufficient clearance when travelling on rail. Both the setting of the front axle lock and the position of the railgear within the lower guide tube clamps affect the clearance height. If the front tires are less than 1.5” from the rails when the railgear is in the rail position per AREMA Standards (American Railway Engineering and Maintenance-of-Way Association, Maintenance-of-Way Work Equipment, AREMA Manual for Railway Engineering, 2006, Section 2.7.18, Point C) OR the front rail wheels are less than 7” from the ground when the railgear is in the road position OR the front tires are less than 3” from the rails when operating in colder locations or on Railways that use switch heaters etc., the front tire clearance must be adjusted as follows:

1. Ensure that the vehicle front axle lock is correctly adjusted as per the Front Axle Lock Operation, Service and Parts manual.
2. Determine how much the railgear must be adjusted up or down to obtain the correct road and rail clearance.
3. With the railgear in the road position, support the railgear axle. Loosen the six 1/2” fasteners that hold the outer guide tubes within the lower outer guide tube clamps.
4. Adjust the railgear height as required by sliding the railgear up or down within the outer guide tube clamps.
5. Re-torque the 1/2” fasteners to 40 ft-lbs dry. Do not over torque.
6. Ensure that the railgear will not contact any vehicle components throughout the full range of railgear and railgear suspension movement.
7. Re-check the road and rail clearances and re-adjust if necessary.
8. If the correct height cannot be achieved using the clamps, the railgear mounting height must be adjusted. Support the railgear and remove the 3/4” fasteners that hold the railgear on the front mounting plates. Raise the railgear so that the next set of railgear mounting holes align with the mounting plate slots. Re-install the 3/4” fasteners and torque them to 175 ft-lbs dry. Do not over torque. Follow the Railgear Alignment procedure provided in this manual.
9. Re-adjust the railgear lock system if necessary, as per the Railgear Lock System Adjustment procedure provided in this manual.
10. Ensure that the collars are welded onto the railgear outer guide tubes so that they are tight against the upper cross frame clamps.

RAILGEAR LOCK SYSTEM ADJUSTMENT

The front railgear lock system provides a mechanical locking hook to hold the railgear axle in the road position. For the system to function properly, the hook must be able to engage and disengage easily from the latch without any obstructions. If the hook is not aligned with the latch, the hook position can be adjusted as follows:

1. Remove the 1/2" fastener holding the hook between the hook supports.
2. Align the hook with the upper, middle or lower set of holes in the hook supports as required.
3. Re-install the 1/2" fastener. Tighten but do not torque this fastener, as the hook must be free to swing.
4. Loosen the four 3/8" fasteners that hold the hook supports on the railgear.
5. Slide the hook supports up or down on the railgear as necessary to align the hook with the hook latch.
6. Torque the four 3/8" fasteners that hold the hook supports to the railgear to 40 ft-lbs dry. Do not over torque.
7. Ensure that the hook can engage and disengage freely without any obstructions. If further adjustment is required, repeat the above steps.



-WARNING-



If any components of the locking system become worn or damaged, components must be replaced with Rafna approved parts and unit put back to fully functioning condition. Any modifications/alterations to the railgear to circumvent this will void any warranty/support from Rafna on future issues. This includes, but is not limited to, drilling of the outer and inner guide tubes for a pinned/bolted connection lockup in the road or rail position. Failure to heed to this warning could result in severe bodily injury and/or equipment damage.

RAILGEAR ALIGNMENT

The railgear must be correctly aligned to perform properly, safely, and avoid excessive wear and derailment. The rail wheels can be independently aligned for toe-in/toe-out and the railgear can be adjusted side to side (laterally) on the vehicle. A parallel line system and the following procedure should be used to perform the railgear alignment.

The vehicle front tire clearance adjustment procedure must be completed, the vehicle should have had a four-wheel alignment (with the complete railgear package installed on the vehicle and any suspension modifications done) and the tires should be properly inflated prior to performing the railgear alignment.

The railgear alignment is done with the vehicle on a straight and level section of rail with the railgear in the rail position and the vehicle wheels pointing straight ahead. The individual rail wheel alignment should be done first, followed by the lateral alignment of the railgear.

Loosening the four 1/2" fasteners that secure it to the railgear axle aligns each rail wheel. The rail wheel is then turned into alignment. The four 1/2" fasteners should then be tightened and torqued to 100 ft-lbs. dry. Do not over torque.

The railgear is aligned laterally by loosening the four 3/4" fasteners that secure it to the railgear mounting plates. The railgear is then moved sideways into alignment. It may be necessary to raise the railgear off the rails to move the railgear side to side. Do not use any force against the railgear guide tubes as this may damage them and restrict suspension movement. The four 3/4" fasteners should then be tightened and torqued to 175 ft-lbs dry. Do not over torque.

Refer to Figure 3 for alignment measurement and specifications. Use an 18" magnetic straight edge on the back of each rail wheel to measure from.

Following the railgear alignment, the railgear may contact the vehicle if not enough clearance was left during installation. Check the railgear clearance to all vehicle components throughout the full range of railgear and railgear suspension movement. If there is interference with the vehicle bumper, it can be trimmed and reinforced as required. If there is interference with the vehicle exhaust system, it can be bent to fit, ensuring any exhaust system modifications conform to applicable laws and regulations. If there is interference with any other vehicle components, please call G&B Specialties Inc. for technical assistance.

WHEEL WEAR STANDARDS AND RECOMMENDATIONS

At the present time, G&B produces 8", 10", 12", 14", and 16" steel wheels. Each size has a different flange and tread thickness, which dictates the allowable wear. Although the following numbers are recommended limits, risk of failure is increased when not followed. Rail gauge can be supplied by G&B Specialties for 8", 10", 12", 14", and 16" rail wheels. They are used as go/no go gauges. When placed on rail wheels they will indicate how much wear is still permissible or if the rail wheels need to be replaced.

The gauge for the R-450 model railgear can be ordered using the following part number; S-001200

- Rail wheel failure can result in equipment damage or failure, personal injury, or death.

Flange Wear Limits:

The maximum flange wear is indicated on the rail wheel gauge. When the gauge is placed on the rail wheel, if a gap is seen between the gauge and the maximum flange wear line, the rail wheel needs to be replaced.

Tread Wear Limits:

For tread wear, use the following chart in conjunction with the appropriate rail wheel gauge.

NOMINAL RAIL WHEEL DIAMETER (INCHES)	MIN. ALLOWABLE WHEEL DIAMETER (INCHES)
10	9 3/4

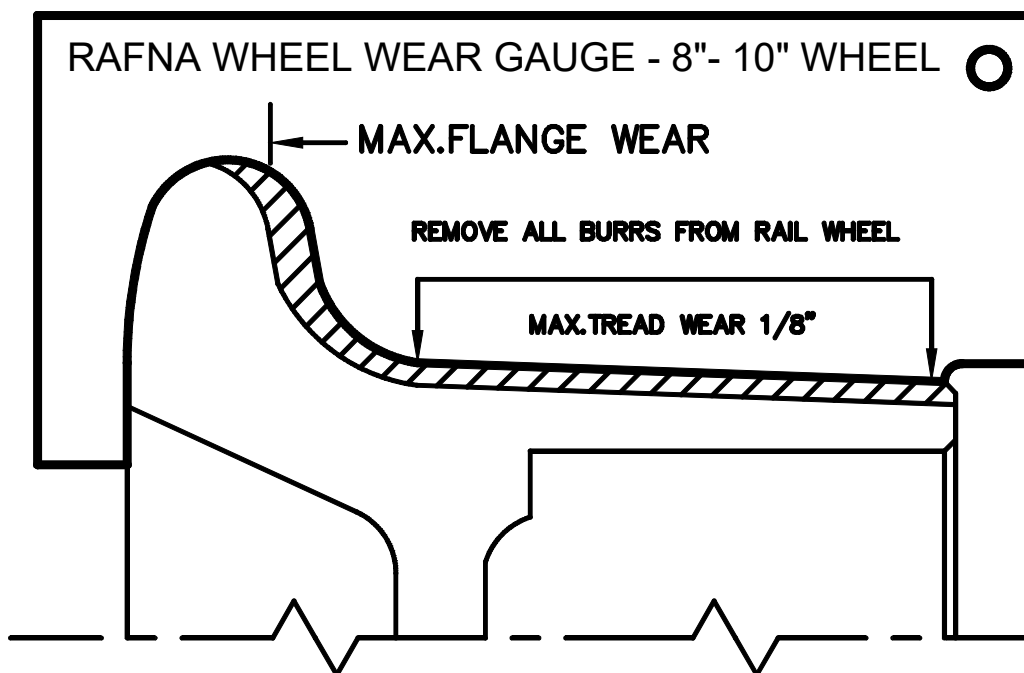

RAFNA RAILGEAR ALIGNMENT RACK DATA

GAS OR DIESEL _____ VIN# _____

VEHICLE MAKE: _____ VEHICLE MODEL: _____ VEHICLE YEAR: _____
 DOOR STICKER GVWR: _____ DOOR STICKER GAWR FRT: _____ DOOR STICKER GAWR RR _____
 RAILGEAR S/N: FRT _____ RR _____ VEHICLE UNIT #,S/N: _____
 RAILGEAR TYPE: _____ INSTALLER: _____ DATE: _____

SET UP PARALLEL STRING LINES
 A & B MUST BE EQUAL WITHIN 1/32"
 C & D MUST BE EQUAL WITHIN 1/32"

ADJUST STRING LINES AROUND VEHICLE
 E, F, G, & H MUST BE EQUAL WITHIN 1/16"
 I, J, K, & L MUST BE EQUAL WITHIN 1/16"
 (E, F, G, & H MAY NOT EQUAL I, J, K, & L)

ADJUST RAIL WHEEL ALIGNMENT
 M & O MUST BE EQUAL WITHIN 1/16"
 N & P MUST BE EQUAL WITHIN 1/16"
 Q & S MUST BE EQUAL WITHIN 1/16"
 R & T MUST BE EQUAL WITHIN 1/16"

ADJUST RAILGEAR LATERAL ALIGNMENT
 M & O MUST EQUAL N & P WITHIN 1/8"
 Q & S MUST EQUAL R & T WITHIN 1/8"

ENSURE THAT U & V ARE BETWEEN
 53- 7/16" AND 53-9/16"

OVER-CENTER ANGLE (DEGREE)
 FRONT _____
 REAR _____

RAIL WHEEL LOADS (LBS)
 LEFT FRONT _____ RIGHT FRONT _____
 LEFT REAR _____ RIGHT REAR _____

RAIL WHEEL FLANGE TO GROUND CLEARANCE
 LEFT FRONT _____ RIGHT FRONT _____
 LEFT REAR _____ RIGHT REAR _____

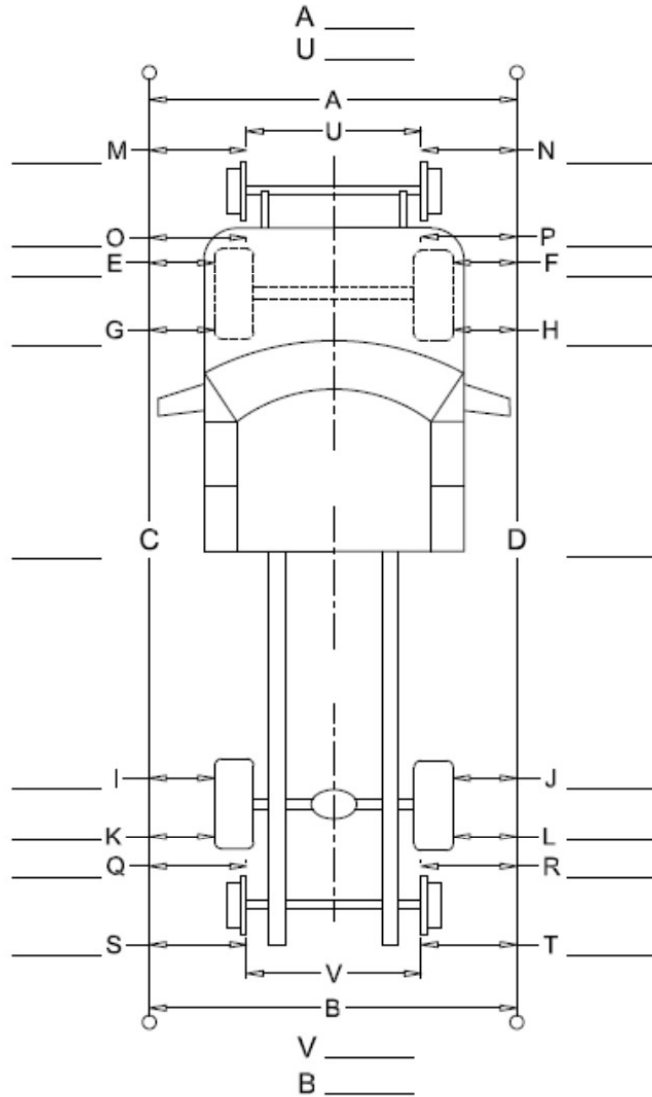

MOUNTING HEIGHT FRONT: _____ MOUNTING HEIGHT REAR: _____
 STOCK TURNING DIAMETER: _____ MODIFIED TURNING DIAMETER: _____
 OEM: VEHICLE WEIGHT: _____ FRONT GAWR: _____ REAR GAWR: _____
 MODIFIED: VEHICLE WEIGHT: _____ FRONT GAWR: _____ REAR GAWR: _____

FAX COMPLETED FORM TO JAKE SANUTE AT FAX # 570-802-0491

MAY 31, 2018 REV "D"

RAFNA RAILGEAR PORTABLE ALIGNMENT DATA

GAS OR DIESEL _____ VIN# _____

VEHICLE MAKE: _____ VEHICLE MODEL: _____ VEHICLE YEAR: _____

DOOR STICKER GVWR: _____ DOOR STICKER GAWR FRT: _____ DOOR STICKER GAWR RR _____

RAILGEAR S/N: FRT _____ RR _____ VEHICLE UNIT #,S/N: _____

RAILGEAR TYPE: _____ INSTALLER: _____ DATE: _____

ADJUST RAILGEAR LATERAL ALIGNMENT
A MUST EQUAL B WITHIN 1/8"
C MUST EQUAL D WITHIN 1/8"

ENSURE THAT U & V ARE BETWEEN
53- 7/16" AND 53-9/16"

OVER-CENTER ANGLE (DEGREE)
FRONT _____
REAR _____

RAIL WHEEL LOADS (LBS)
LEFT FRONT _____ RIGHT FRONT _____
LEFT REAR _____ RIGHT REAR _____

RAIL WHEEL FLANGE TO GROUND CLEAR-
ANCE
LEFT FRONT _____ RIGHT FRONT _____
LEFT REAR _____ RIGHT REAR _____

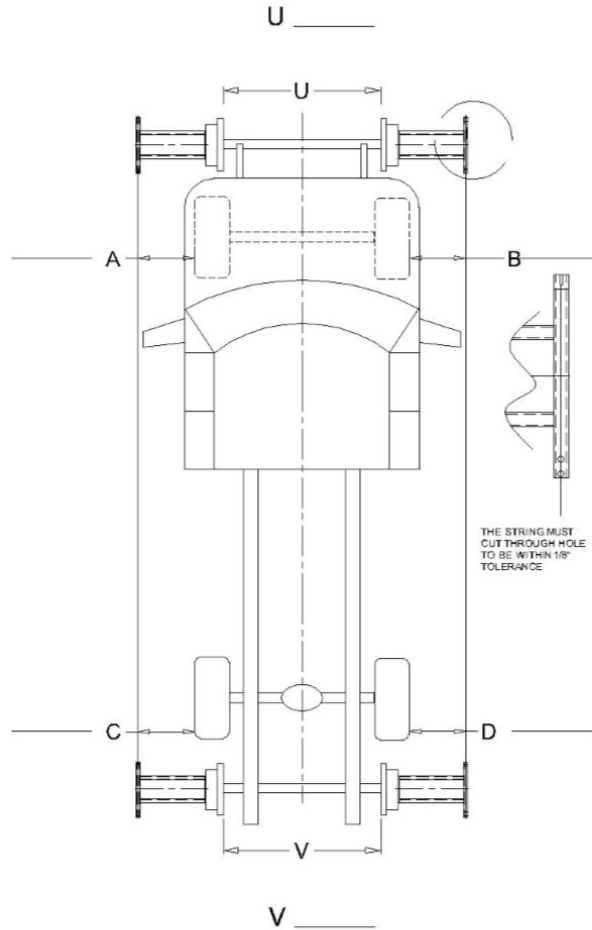

MOUNTING HEIGHT FRONT: _____ MOUNTING HEIGHT REAR: _____

STOCK TURNING DIAMETER: _____ MODIFIED TURNING DIAMETER: _____

OEM: VEHICLE WEIGHT: _____ FRONT GAWR: _____ REAR GAWR: _____

MODIFIED: VEHICLE WEIGHT: _____ FRONT GAWR: _____ REAR GAWR: _____

FAX COMPLETED FORM TO JAKE SANUTE AT FAX # 570-802-0491

MAY 31, 2018 REV B

PARTS OF VERTICAL FRONT RAILGEAR KIT

PARTS LIST			QTY
ITEM	PART NUMBER	DESCRIPTION	
1	R-4530	FRONT AXLE ASSEMBLY	1
2	R-556	TIMBRENS SPRINGS, FRONT R-450	2
3	R-1017	FRONT HYDRAULIC CYLINDER PISTON ASSEMBLY	2
4	R-923	COVER PLATE	2
5	R-554	FRONT INNER TUBE ASSEMBLY	2
6	R-553	FRONT OUTER TUBE	2
7	R-4654	R-450 FRONT CROSS CHANNEL ASSEMBLY	1
8	R-555	FRONT HYDRAULIC CYLINDER (2" BORE x 15" STROKE)	2
9	R-1010	UPPER FRONT CROSS FRAME	1
10	R-1017A	PLASTIC SPACER	2
11	R-3591	FRONT BELLOWS R-450	2
12	R-602	BELLOWS CLAMP	2
13	S-002001	VALVE, DOUBLE PILOT OPERATED CHECK	1
14	R-1604	FRONT HOOK BRACKET	2
15	R-1028A	FRONT AXLE HOOK	1
16	K-R45VFM10700	R-450 VERTICAL FRONT MECHANICAL LOCK (PAIR)	1
17	H.H.C.S.	3/8" X 1 1/4" LG, UNC, GR.8	1
18	H.H.C.S.	3/8" X 2" LG, UNC, GR.8	4
19	H.H.C.S.	1/2" X 2 1/4" LG, UNC, GR.8	8
20	H.H.C.S.	1/2" X 2 1/2" LG, UNC, GR.8	10
21	H.H.C.S.	3/4" X 3 1/2" LG, UNC, GR.8	1
22	H.H.C.S.	3/4" X 5 1/2" LG, UNC, GR.8	2
23	F WASHER	3/8" TYPE A, GR. 8	24
24	F WASHER	1/2" TYPE A, GR. 8	22
25	F WASHER	3/4" TYPE A, GR. 8	8
26	NYLOCK NUT	3/8" UNC GR.8 NYLOCK NUT	12
27	NYLOCK NUT	1/2" UNC GR.8 NYLOCK NUT	11
28	NYLOCK NUT	3/4" UNC GR.8 NYLOCK NUT	4
29	990900-009	1/8 NPT 5T ZERK	4
30	SPRING PIN	5/16" X 1 3/4"	2

NOTES

- HARDWARE KIT REFERENCE: R-990KIT-047
- HYDRAULIC KIT REFERENCE: H-990KIT-005
- BELLOWS SHOWN COMPRESSED
- APPROXIMATE WEIGHT: 299 POUNDS

REV	DESCRIPTION OF CHANGES	DATE	BY	APPRVD	ECN #
0	REVISION A RELEASED	6/21/99	V.Z.		
A	GENERAL UPDATE	03/05/07	V.Z.		
B	ADD HARDWARE HYDRAULIC TABLE	12/04/02	V.Z.		
C	ADDED ITEM 21	01/27/03	V.Z.		
D	UPDATE ITEM 1	08/04/03	R.H.		
E	UPDATE ITEM 9 REDREW R-555 TO SHOW R4556	07/08/05	G.D.		
F	ADDED AXLE LOCK, REVISED BOM	05/03/12	AHL		
G	COMPLETE REDRAW TO MATCH MASTER	10/21/19	SDB	JMP	ECN:19-754
H	ISO2001 WAS 5-02-2002	11/26/24	SMM	JMP	ECN:24-519

ALL WELDS TO CONFORM TO AWS D1.1

G & B SPECIALTIES INC.
MANUFACTURER OF QUALITY RAILROAD PRODUCTS
BERWICK, PENNSYLVANIA 02017-250-5901 FAX: (570) 752-6397

DESIGN - ENGINEERING - MANUFACTURING

R-450 FRONT UNIT FOR SHIPMENT

DATE SHOWN: 6/21/99
PART NUMBER: R-4531AC
REL: H

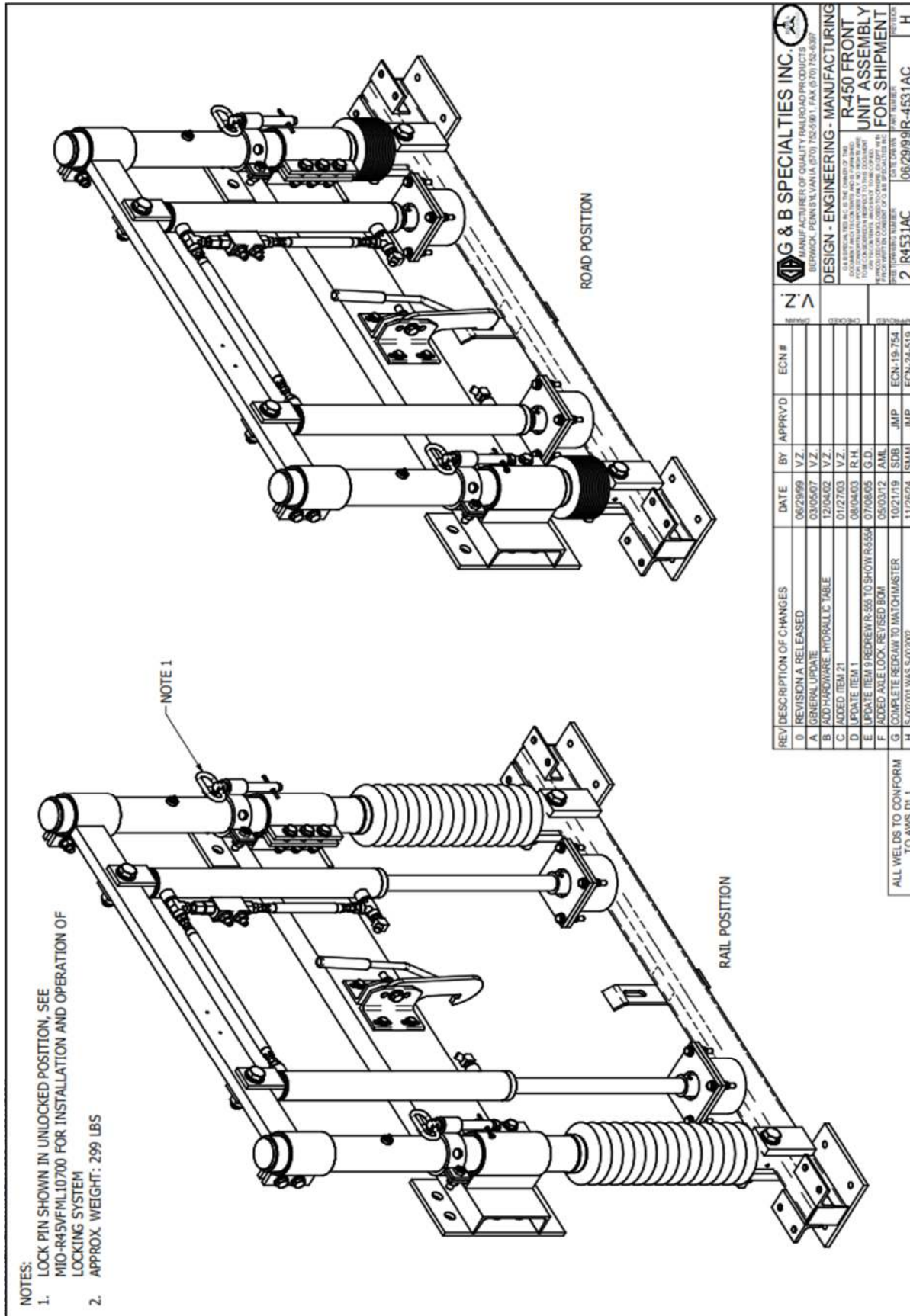

REV	DESCRIPTION OF CHANGES	DATE	BY	APPRVD	ECN #
0	REVISION A RELEASED	06/28/99	V.Z.		
A	GENERAL UPDATE	03/05/07	V.Z.		
B	ADD HARDWARE HYDRAULIC TABLE	12/04/02	V.Z.		
C	ADDED ITEM 21	01/27/03	V.Z.		
D	UPDATE ITEM 1	08/04/03	R.H.		
E	UPDATE ITEM 9 REDRAWN-555 TO SHOW R6358	07/08/05	G.D.		
F	ADDED AXLE LOCK, REVISED BOM	05/03/12	AML		ECN-19-754
G	COMPLETE REDRAW TO MATCH MASTER	10/21/19	SDB	JMP	ECN-24-519
H	5-002/001 WAS 5-002/002	11/26/24	SMM	JMP	

ALL WELDS TO CONFORM TO AWS D1.1

G & B SPECIALTIES INC.
MANUFACTURER OF QUALITY RAILROAD PRODUCTS
BERWICK, PENNSYLVANIA (570) 752-5901, FAX (570) 752-6397

DESIGN - ENGINEERING - MANUFACTURING

R-450 FRONT UNIT ASSEMBLY FOR SHIPMENT

DATE DRAWN: 06/29/99
PART NUMBER: R-4531AC
REVISION: H

2 | R4531AC

NOTES:

- ASSEMBLE AS SHOWN.
- BEARINGS ARE TO BE PACKED WITH GREASE AT ASSEMBLY. USE MYSTIK JT-6 LOW TEMP GREASE OR EQUIVALENT.
- BEARING TORQUE PROCEDURE:
 - While rotating the rail wheel forward, torque the bearing nut to 20 ft-lbs., loosen nut and repeat.
 - Loosen the bearing nut and re-torque to 6 ft-lbs.
 - Check bearing end play with a magnetic dial indicator. End play should be within 0.001" - 0.005"
 - If bearing end play is not within the required specification, bearings should be re-torqued following the procedure outlined in steps A thru C.

ASSEMBLE WITH BLUE LOCTITE

11 10

BILL OF MATERIAL/PARTS LIST

ITEM	QTY	PART NUMBER	DESCRIPTION
1	1	R-001D	10" WHEEL SUB-ASSEMBLY, MODIFIED ASSEMBLY
2	2	R-010	TAPERED ROLLER BEARING CONE (LM104949)
3	1	R-011	TAPERED ROLLER BEARING CUP (LM104911)
4	1	R-014	SLOTTED WASHER
5	1	R-009	OIL SEAL (#471271)
6	1	R-017A	10" WHEEL Gasket
7	1	R-020	10" STEEL WHEEL
8	1	R-017	HUB CAP ASSEMBLY (10" WHEEL)
9	1	990900-009	FITTING, 1/8" STR PTF
10	3	990722-075-22F	SCREW, 1/4"-28 X 3/4" GR 8 HEX Z/Y
11	3	990402-025-02	WASHER, 1/4" Hvy LOCK Z/Y
12	1	990507-125-02	COTTER PIN, 5/32" X 1 1/4" Z/Y
13	1	R-016	NUT, 3/4"-16 UNF REG HEX SLOTTED Z/Y

SECTION A-A

REV/DESCRIPTION OF CHANGES	DATE	BY	APPR/VD	ECN #
E ADDED ITEM #1: REVISED BOM	12/07/06	AVL	JMP	ECN-17-466
F UPDATED BOM AND BOARDER	08/14/17	SMW	JMP	ECN-18-423
G ADDED NOTE ON WHEEL HUB	05/22/18	JEV	JMP	ECN-18-423
H REVISED DRAWING, ADDED GREASE NOTE	04/14/21	SMW	JMP	ECN-21-210

G & B SPECIALTIES INC.
MANUFACTURER OF QUALITY RAILROAD PRODUCTS
BERWICK, PENNSYLVANIA (570) 752-5901 FAX (570) 752-6397
DESIGN - ENGINEERING - MANUFACTURING

10" WHEEL ASSEMBLY

DATE DRAWN: 12/01/06
PART NUMBER: R-001
REVISION: H

BILL OF MATERIALS/PARTS LIST			
ITEM	PART NUMBER	DESCRIPTION	QTY
1	R-1002L	RAIL SWEEP BRACKET	1
2	R-5561	SWEEPER PLATE	1
3	R-2411	RUBBER SWEEP	1
4	R-990KIT-007	1/4" UNC GR.8 BOLT X 1.25" LONG	4
5		1/4" SAE WASHER	4
6		1/4" UNC GR.8 NYLOCK NUT	2

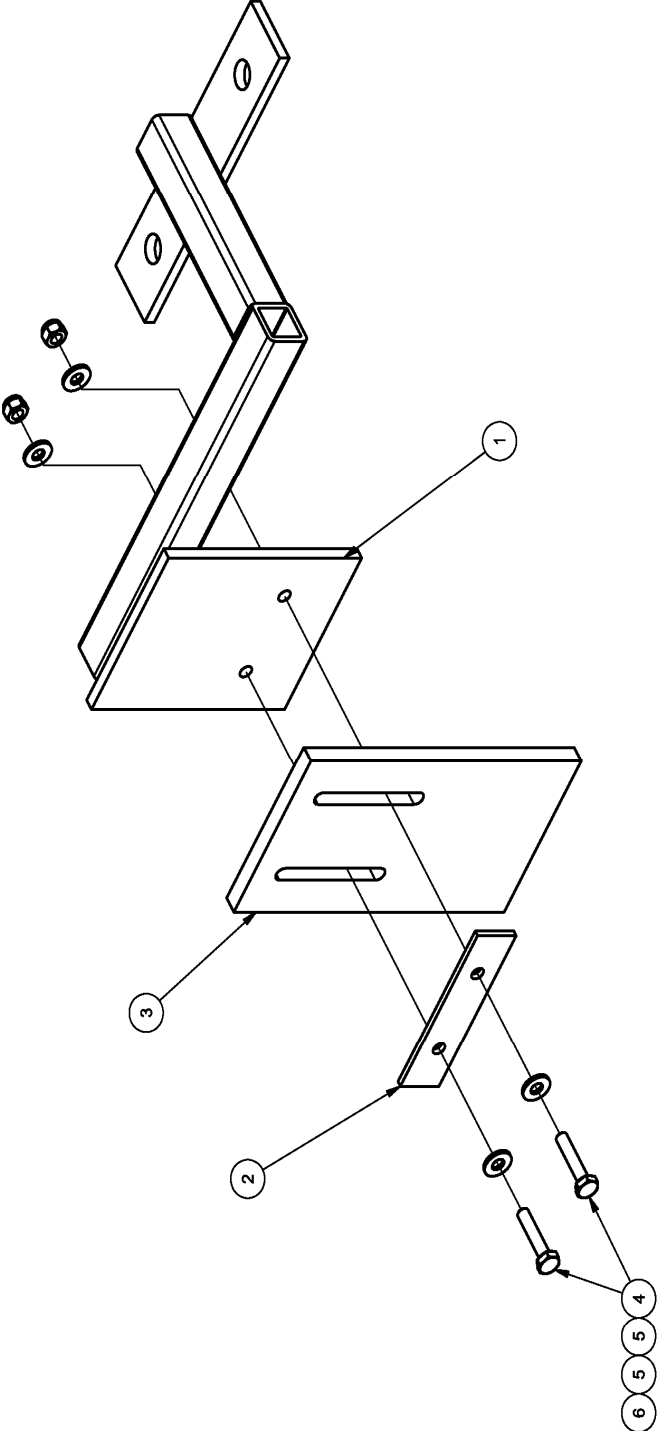

REV	DESCRIPTION OF CHANGES	DATE	BY	APPRVD	ECN #	APPROVED	DRAWN	FILE
A	UPDATED BORDER & BLOCK	6/12/19	AJB					
B	CORRECTED PART NUMBER	01/12/22	SMM	JMP				

G & B SPECIALTIES INC.
MANUFACTURER OF QUALITY RAIL ROAD PRODUCTS.
BERWICK, PENNSYLVANIA (570) 752-5901, FAX (570) 752-6397
DESIGN - ENGINEERING - MANUFACTURING
DOCUMENT AND ITS CONTENTS ARE TO BE CONSIDERED IN RESPECT TO THE DOCUMENT TO BE REPRODUCED OR TRANSMITTED IN ANY FORM OR BY ANY MEANS, ELECTRONIC OR MECHANICAL, INCLUDING PHOTOCOPYING, RECORDING, OR BY ANY INFORMATION STORAGE AND RETRIEVAL SYSTEM.
REPRODUCTION OR TRANSMISSION OF THIS DOCUMENT WITHOUT THE WRITTEN PERMISSION OF G&B SPECIALTIES INC. IS PROHIBITED.
FRONT RAIL SWEEP ASSEMBLY PASS SIDE
BRETT DRAWING NUMBER DATE DRAWN PART NUMBER REVISION
1 R-1000L 11/18/04 R-1000L B

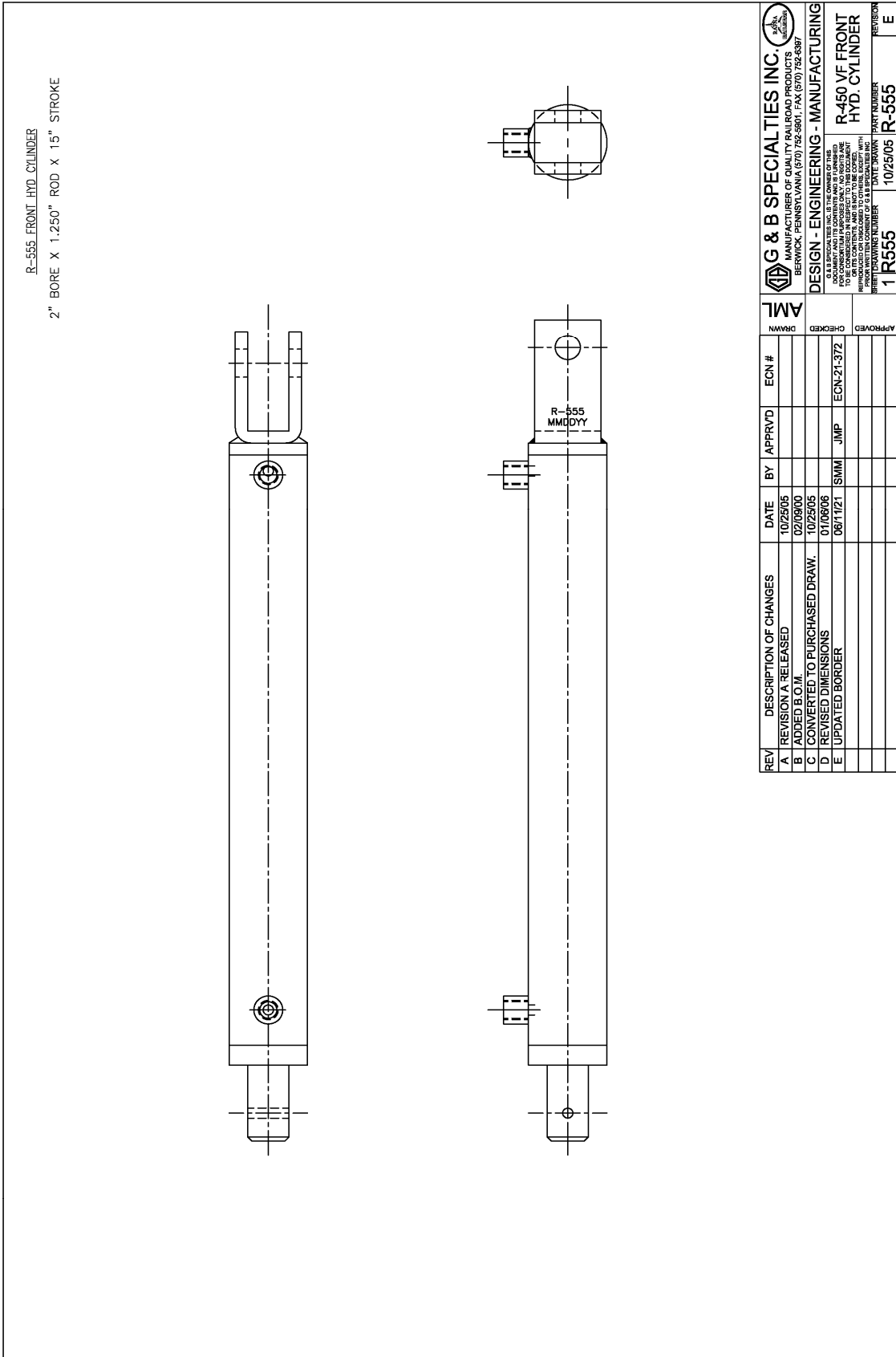

REV	DESCRIPTION OF CHANGES	DATE	BY	APPRVD	ECN #	APPROVED	DRAWN
A	REVISION A RELEASED	10/25/05					AML
B	ADDED B.O.M.	02/09/06					
C	CONVERTED TO PURCHASED DRAW.	10/23/05					
D	REVISED DIMENSIONS	01/06/06					
E	UPDATED BORDER	06/11/21	SMM	JMP	ECN-21-372		

G & B SPECIALTIES INC.
MANUFACTURER OF QUALITY RAILROAD PRODUCTS
BERWICK, PENNSYLVANIA (570) 752-5901, FAX (570) 752-6397
DESIGN - ENGINEERING - MANUFACTURING

AS A SPECIALTY ITEM, IT IS THE OWNER'S RESPONSIBILITY TO VERIFY THE PART NUMBER AND QUANTITY ORDERED. NO PARTS ARE TO BE ORDERED WITHOUT WRITTEN CONSENT OF G & B SPECIALTIES INC.

1 R555 **10/25/05** **R-555**

R-450 VF FRONT HYD. CYLINDER

PART NUMBER QUANTITY REVISION

ITEM NUMBER	PART NUMBER	DESCRIPTION	QUANTITY
1	R-555	RAILGEAR HYDRAULIC CYLINDER	2
2	S-002001	DOUBLE P.D. CHECK VALVE	1
3	24SA-06	3/8" MALE NPT TO 3/8" MALE NPT	1
4	24SB-06-04	3/8" MALE NPT TO 1/4" FEMALE NPT	2
5	25VK-06	3/8" MALE NPT TO 2X 3/8" FEMALE NPT	2
6	720FSD-06-06	3/8" MALE O-RING BOSS TO 3/8" FEMALE NPT	2
7	848FS-04-06	1/4" MALE JIC TO 3/8" MALE NPT	3
8	854FS-04-04	1/4" MALE JIC TO 1/4" MALE NPT 45°	2
9	848FSD-04-06	1/4" MALE JIC TO 3/8" MALE O-RING BOSS	3
10	HFS2-04	HOSE 3.5' LONG	1
11	HFS2-04	HOSE 13.5' LONG	1
12	HFS2-04	HOSE 18' LONG	1
13	HU04-04NJ	1/4" FEMALE JIC STRAIGHT COUPLER	6

MANUFACTURING NOTES:

Legend: **S** = Ship
1 = Stop Install
13 = Stop Install Sub Assembly
△ = Supplied By Others

WEIGHT (LBS):

REV	DESCRIPTION OF CHANGES	DATE	BY	APPRVD	ECN #
A	REVISION A RELEASED	11/25/04			
B	UPDATED BORDER	06/11/21	SMM	JMP	
C	CHANGED TO A DOUBLE PO CHECK	11/27/24	SMM	JMP	

G & B SPECIALTIES INC. MANUFACTURER OF RAILROAD PRODUCTS BERWICK, PENNSYLVANIA (570) 752-5901, FAX (570) 752-6397	R.I.	DESIGN - ENGINEERING - MANUFACTURING
ALL SPECIAL TOOLING IS THE PROPERTY OF THIS COMPANY. IT IS TO BE USED ONLY FOR THE MANUFACTURE OF PRODUCTS SPECIFICALLY IDENTIFIED ON THIS DRAWING. IT IS TO BE KEPT IN GOOD CONDITION AND RETURNED TO THE COMPANY AT THE END OF THE PROJECT.		
HYDRAULIC ASSY. FOR R-4531AC	PART NUMBER R-4531AC-HYD	REVISION C

R-450 PRE-DELIVERY CHECKLIST

This checklist is provided to help ensure that the railgear is properly installed and adjusted prior to the vehicle being put in service. **In order to register this railgear installation, please fax a completed copy of both this form and the railgear alignment sheet to G&B Specialties, Inc. Service Manager at 570-802-0491.**

Railgear Model: _____	Vehicle Year: _____
Railgear Serial No.: <u>Fr</u> _____	Vehicle Make: _____
_____ <u>Rr</u> _____	Vehicle Model: _____
Date Received: _____	Vehicle VIN/Unit #: _____
Date Completed: _____	End User: _____

Railgear Checks

1. _____ Rail wheel bearing end play adjusted (see manuals for procedure)
2. _____ Rail sweeps adjusted (see manuals for procedure)
3. _____ Rail wheel load adjusted (see manuals & fill out values on alignment sheet)
4. _____ Rail wheel alignment performed (attach copy of alignment sheet)
5. _____ Vehicle front tire clearance minimally 1.5" on rail as per AREMA Standards, (American Railway Engineering and Maintenance-of-Way Association, Maintenance-of-Way Work Equipment, AREMA Manual for Railway Engineering, 2006, Section 2.7.18, Point C) OR in colder operation locations and Railways that use switch heaters etc., 3" is suggested for ensured clearance of objects
6. _____ Axle lock-up system clears all possible obstructions (wheels turned and straight)
7. _____ Axle lock-up system engage/disengage smoothly/properly
8. _____ Rear railgear lock system adjusted (see manual for procedure)
9. _____ Front & rear railgear lock systems engage/disengage smoothly
10. _____ Railgear components clear all vehicle component thru full range of motion
11. _____ Railgear operating decals installed next to controls
12. _____ Railgear pump decal installed next to dash switch (if required)
13. _____ Steering wheel lock decal installed on dash
14. _____ Steering wheel lock installed
15. _____ All railgear joints lubricated (see manuals for lubrication points)

Wheel Kit Checks

16. _____ Wheel and spacer lug nuts tightened (see manuals for specifications)
17. _____ Wheel lug nut torque value decals installed on wheels
18. _____ Wheels & tires clear all vehicle components thru full range of motion
19. _____ Rear tires are centered on rail head (inside tread measures no more than 56.5")

Hydraulic Checks

20. _____ Flow from PTO adjusted between 3-5 gpm (if equipped)
21. _____ Air bled from railgear hydraulic system
22. _____ Pump tank filled as required with hydraulic fluid (if required)
23. _____ Brake system operates properly and there are no leaks (if required)
24. _____ Brake pump relief valve adjusted (see manuals for procedure)
25. _____ Railgear relief valve(s) adjusted (see manuals for procedure) (if required)
26. _____ All hydraulic hoses clear of hot / sharp edges and tied back

THIS PAGE INTENTIONALLY LEFT BLANK

4.0 AXLE LOCKUP KIT (ROD, CABLE, & HYDRAULIC)

INSTALLATION SAFETY PRECAUTION

If any installation problems are encountered, please call G&B Specialties for technical assistance before continuing with the installation process.



- Failure to heed to any of the following warnings could result in severe bodily injury and/or equipment damage.
- Read and understand this manual completely before attempting installation of the equipment.
- Installation instructions provided below only address the Rafna railgear equipment. Applicable railway company procedures and policies must be adhered to.
- Before performing any work under the vehicle or railgear, ensure the engine is turned off and the parking brake is set.
- Beware of all pinch points on the railgear and keep all parts of the body clear.
- Ensure all removed components are given to the vehicle owner after the installation of the railgear. These components must be re-installed if the railgear is removed from the vehicle.
- Always disconnect the vehicle's battery when welding on the vehicle or railgear in order to protect the vehicle's electrical system.

INSTALLATION OF ROD OPERATED FRONT AXLE LOCK KIT

The following procedure details the installation of the Rod Operated Front Axle Lock Kit. The hardware required for this installation is listed in the table below.

Table 1: K-R45AVXFX005/K-R45AVXFX023 (R-450 Rod Operated Front Axle Lock Kit)

Part Number	Description	Req.
R-12029D	L-Bracket Weldment Drivers Side	1
R-12029P	L-Bracket Weldment Passengers Side	1
R-5635	Insulator Washer	4
R-4912-A	Hook	2
R-12018	Spacer	2
R-12031	Support Bracket	2
R-4911	Bracket (FOR MY 17-22 VEHICLES)	2
R-4923	Bracket (FOR MY 23 & UP)	2
R-4914	Hook Catch	2
R-6944	Rod Guide	2
R-6947	Lock Tab	4
R-6948A	Pull Rod	2
R-1650	Plate	2
R-4686	Quick Release Pin	2
R-12032	Washer, Fuel Cooler Spacer	1
R-990KIT-116A	Nylock Nut, UNC, 1/4"	2
	Flat Washer, Type A, 1/4"	2
	Hex Screw, UNC, 3/8" x 4" Lg	2
	Nylock Nut, UNC, 3/8"	4
	Flat Washer, Type A, 3/8"	6
	Nylock nut, UNC, 1/2"	2
	Flat Washer, Type A, 1/2"	8
	Hex Screw, UNC, 3/4" x 5" Lg	2
	Hex Screw, UNC, 3/4" x 5 1/2" Lg	2
	Nylock nut, UNC, 3/4"	6
	Flat Washer, Type A, 3/4"	10
	Cotter pin, 3/16" x 2" Lg	2

The manual front axle lock kit is to be positioned just rearward of the vehicle's front suspension springs. Mounting holes in the hook hanger and bracket will align with some existing holes in the vehicle frame and suspension arm, respectively. The axle lock hook is designed to swing toward the front of the vehicle while disengaged for the road position and toward the rear of the vehicle while engaged for the rail position. The pull rod is fastened to the hook and routed toward the front of the vehicle to control the hook position.

1. Remove fuel cooler (Figure 8) from inside frame. Hoses should not have to be removed, just bolts taken out to be free of the frame. We will be using one of the existing mounting points for our bracket. Clip will need to be removed from square hole. See (Fig.5) for location.

2. Pop out wiring clips, grounding stud, etc. on top of the frame so that the bracket with sit flat on the frame. Brake clip and grounding stud are located on bracket for re-installation. Pop rivet can be removed from brake clip and installed on bracket with supplied hardware. See Fig. 7 for clip and pop rivet.
3. Find the slotted hole on top of the frame. Take bracket R-12029D (Driver's Side) and align the locating slug on the bracket with the slot in the frame. When done correctly, slug should drop into the slot on the frame and the bracket sit against the top and outer surfaces of the frame. See (Fig. 1).
4. With the bracket on the frame, center punch the slot on the bracket. Remove bracket and drill a $49/64$ " hole. Hole should line up with existing square hole where we removed the clip from earlier. Check with supplied $3/4$ " bolt to ensure bolt sits parallel and is not angled. Hole may need to be reamed to ensure this. The hole on the outside of the frame can also be obtained by drilling the square hole on the inside of the frame through to the outside. The bracket is slotted for this reason. Just ensure bolt sits straight and not on an angle. Once hole is in place and bolt sits parallel, re-install fuel cooler leaving out the clip we removed. Install bracket to frame, using R-12032 and $3/4$ " hardware as show in Fig. 1 & 2. See Fig. 8 for proper install reference. (Passenger side will need the hole drilled through to the inside of the frame. There are no holes present on the passenger side.)
5. On the radius arm you will see a slotted hole with a hole next to it. Take R-4911 or R-4923 (Depending on Model Year) and place it on the radius arm with the larger hole in the bracket aligned with the slot, positioned closest to the hole side of the slot. See (Fig.6) Place $3/4$ " bolt that was supplied through the bracket and radius arm to help hold the bracket, and with the bracket against the bottom of the radius arm, mark the center of the small hole of the bracket on frame. You may also mark the center of the hole on the inside of the frame. Drill a $13/32$ " hole through the radius arm, or on the inside and outside where marked. With hole drilled, install bracket using the $3/4$ " and $3/8$ " hardware supplied in kit. See (Fig.1 & 3) for reference. Ensure not to over-tighten bolts and deform the radius arm.
6. Assemble the hook, R-4912-A, and bracket, R-12031, onto the all thread and stud as shown in Fig. 2. If lateral adjustment is required supplied spacer can be trimmed down, or washers can be added into assembly to maintain proper clearance with frame, suspension arm, and hook. Nylock nut should be tightened enough to secure hook, but not hinder it from swinging.
7. Position each hook so that it is hanging vertically with the hooking surface horizontal. Position each hook catch on each bracket so that the vertical side of the hook just touches the forward-most part of the hook catch and there is a minimal gap between the bottom of the hook catch and the hooking surface. Weld each hook catch to each bracket using a $3/8$ " all around fillet weld
8. Position each plate at about the center of the forward-facing vertical edge of each hook as shown. Tack weld each plate to each hook temporarily. (Fig.4)

9. Assemble the short-bent end of each pull rod with each plate as shown using one 1/2" washer and one 3/16" x 2" cotter pin. Route the pull rod around the front suspension coil springs and other vehicle components so that it extends out toward the front of the vehicle alongside the railgear front mounting brackets. The pull rods can be heated and bent to fit. Trim the vehicle front bumper as required. (Fig.4)
10. Slide each rod guide onto each pull rod from the handle end at the front of the vehicle. Position each rod guide so that it is approximately 2-3" from the handle end of the pull rod when the pull rod is pushed all the way in, so the hook engages the hook catch. Tack weld each rod guide to a convenient location on the railgear or vehicle temporarily. Do not weld the rod guide to the railgear guide tubes or hydraulic cylinders. It may be necessary to fabricate a bracket to position the rod guides as desired.
11. Test the stroke of each pull rod to ensure that each hook can be fully engaged and disengaged from the hook catch. Ensure that all parts of the axle lock system are clear of all vehicle components. If necessary, the plates previously tack welded to the vertical edge of the hooks can be relocated to adjust the stroke of the pull rods. The rod guides can also be relocated. Once each plate and rod guide position are verified, fully weld each plate to each hook and fully weld each rod guide to the railgear, vehicle, or fabricated bracket.
12. With each pull rod pushed all the way in so the hook fully engages the hook catch, position one lock tab on the pull rod as shown so the hole in the lock tab aligns with the front most holes in the rod guide. Weld the lock tab to the pull rod.
13. With each pull rod pulled out so that the hook fully disengages the hook catch with at least 1/2" clearance, position one lock tab on the pull rod as shown so the hole in the lock tab aligns with the rear most holes in the rod guide. Weld the lock tab to the pull rod.
14. Attach each pin to each chain on the rod guides. Pull the pull rods to fully disengage the hooks and insert the pins through the rod guides and lock tabs.
15. Paint all areas that were welded or heated.
16. Ensure that there is sufficient clearance between the front axle lock components and all vehicle components through their full range of motion.
17. Test the operation of the front axle lock.

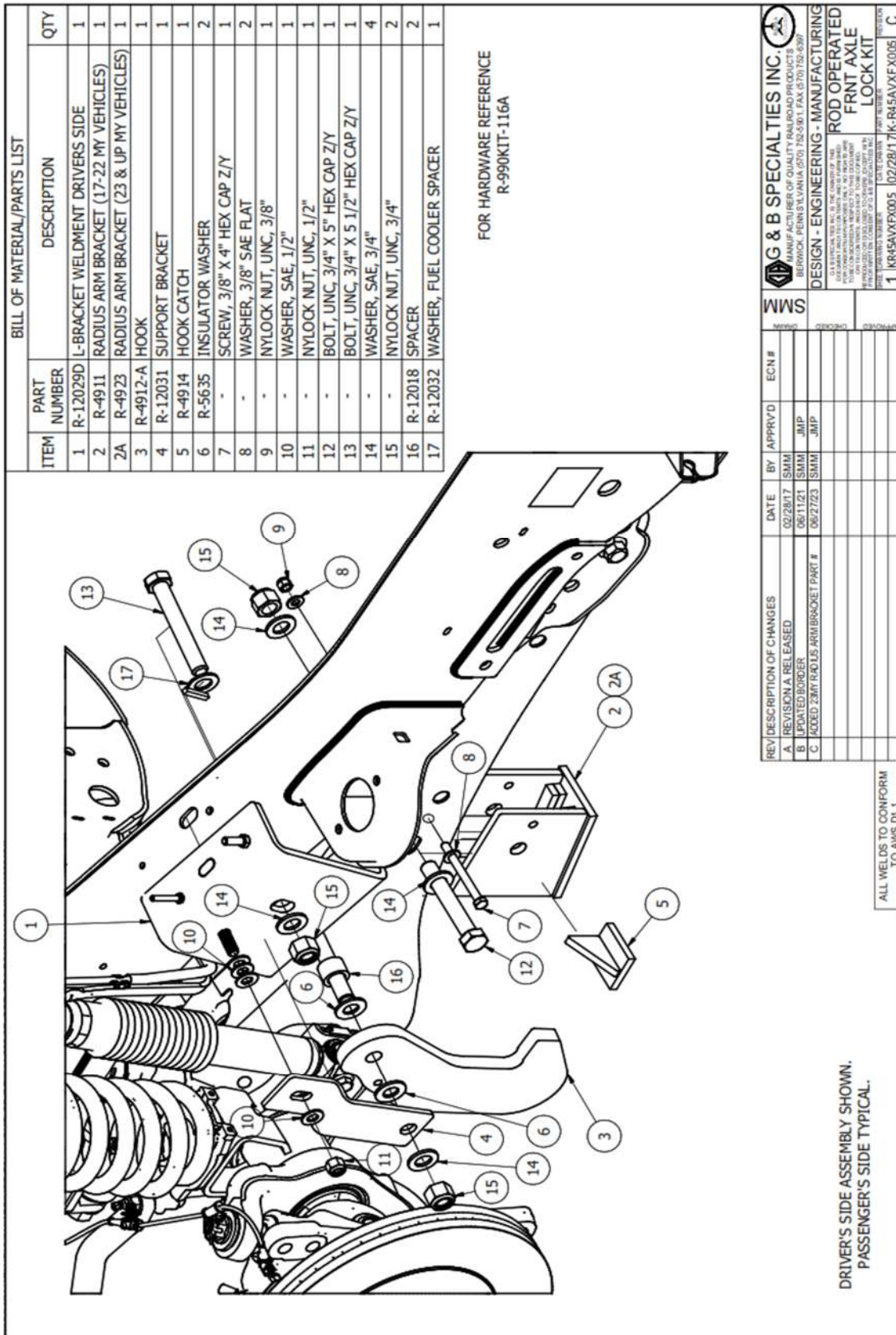

Figure 1

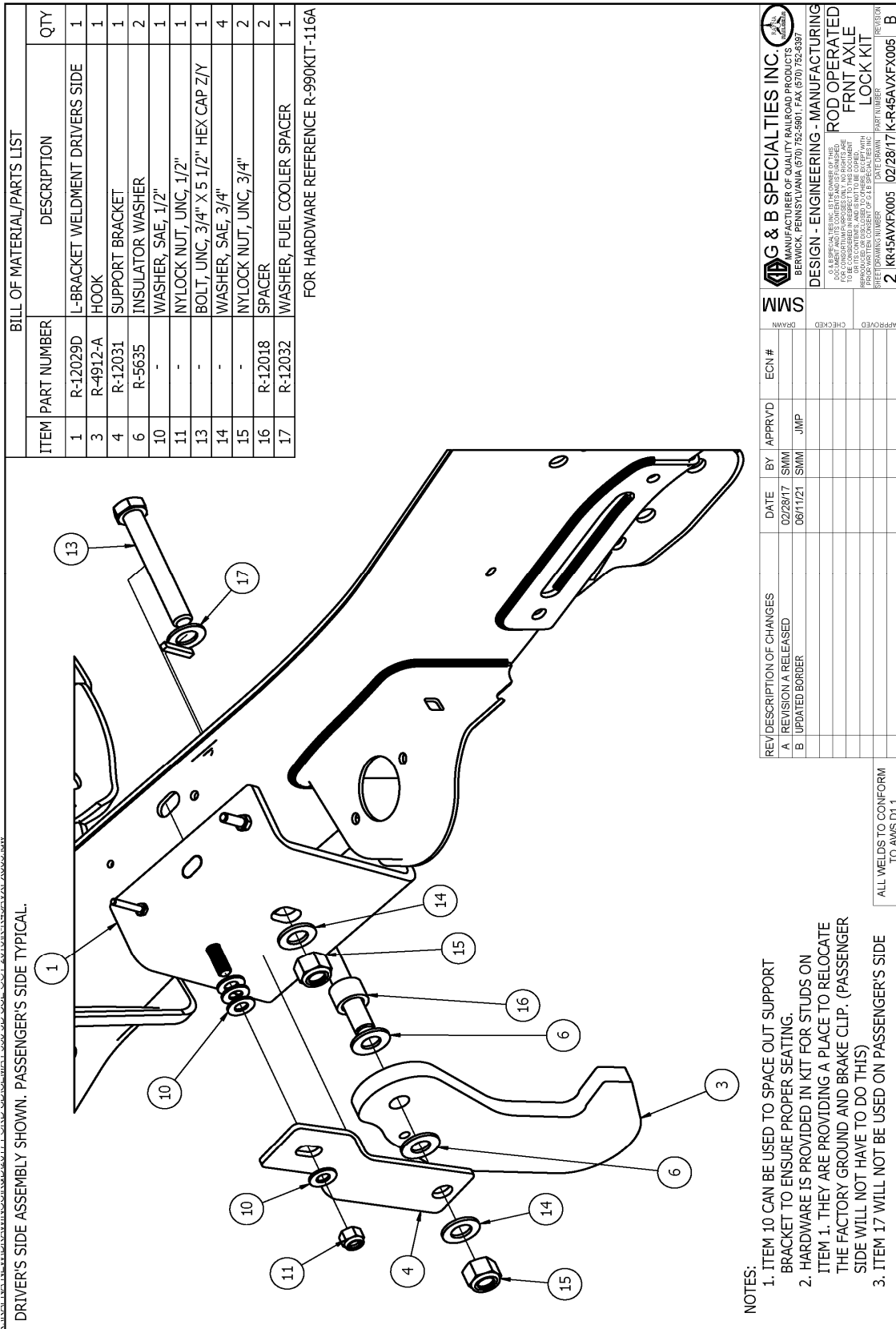

Figure 2

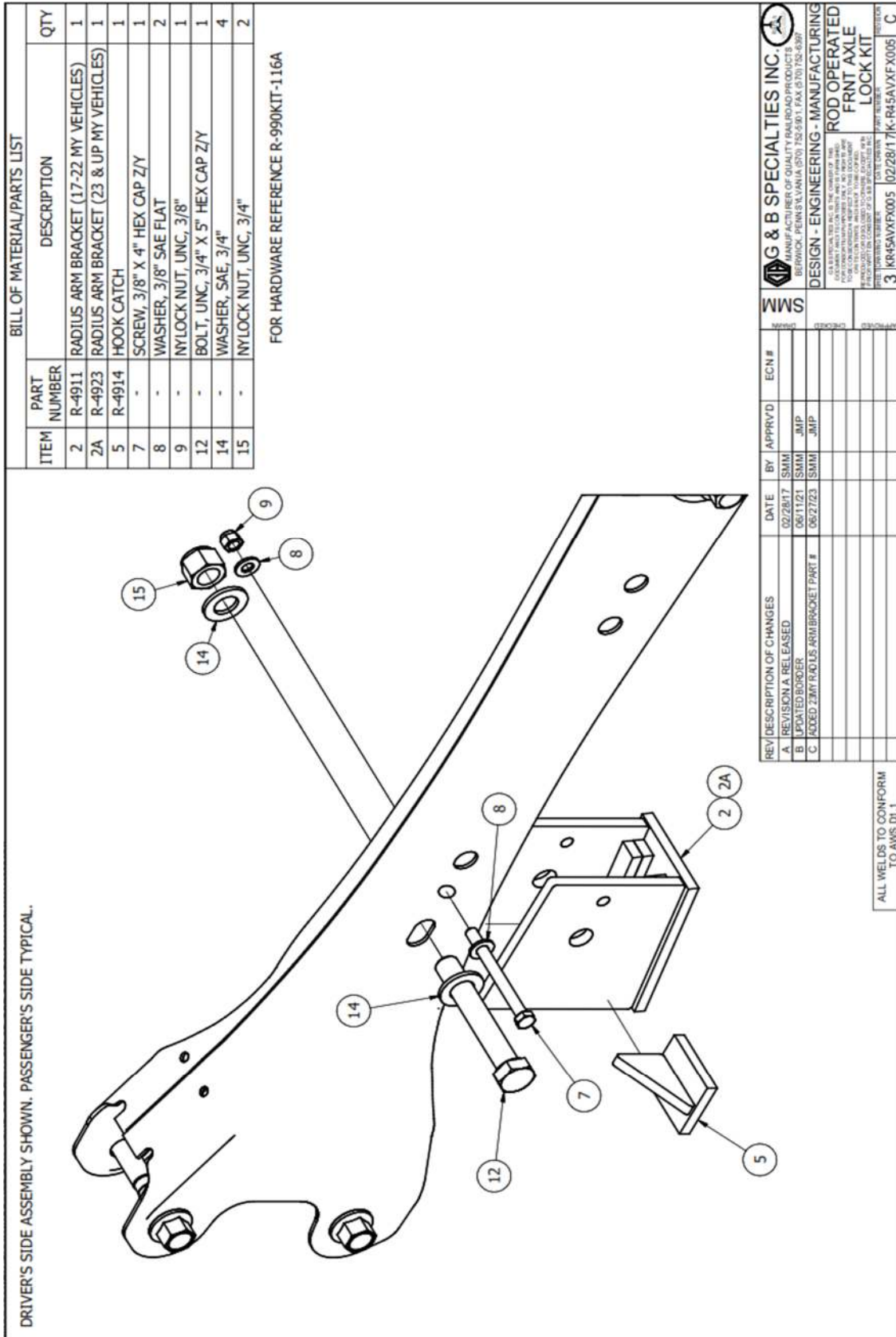

Figure 3

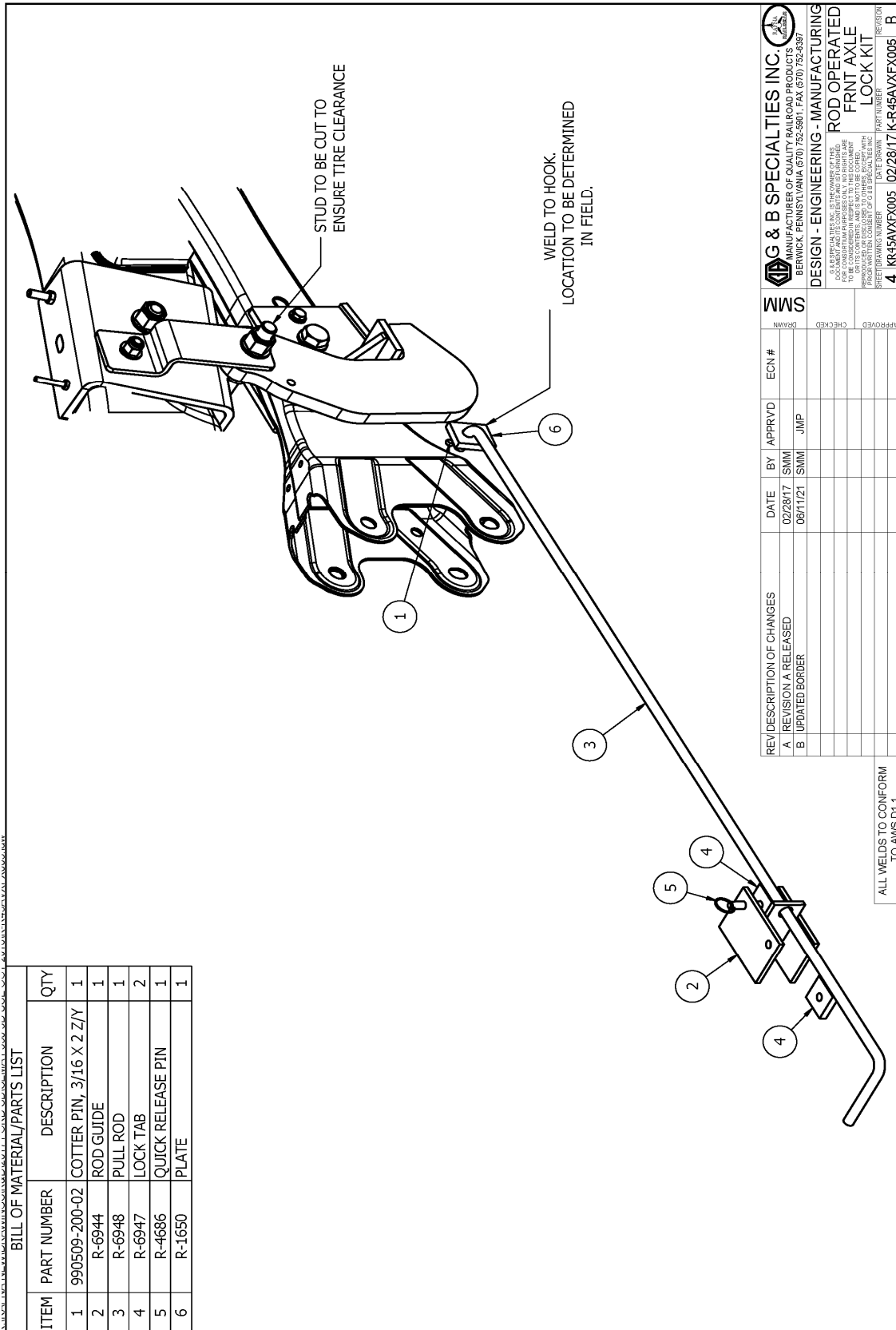

Figure 4

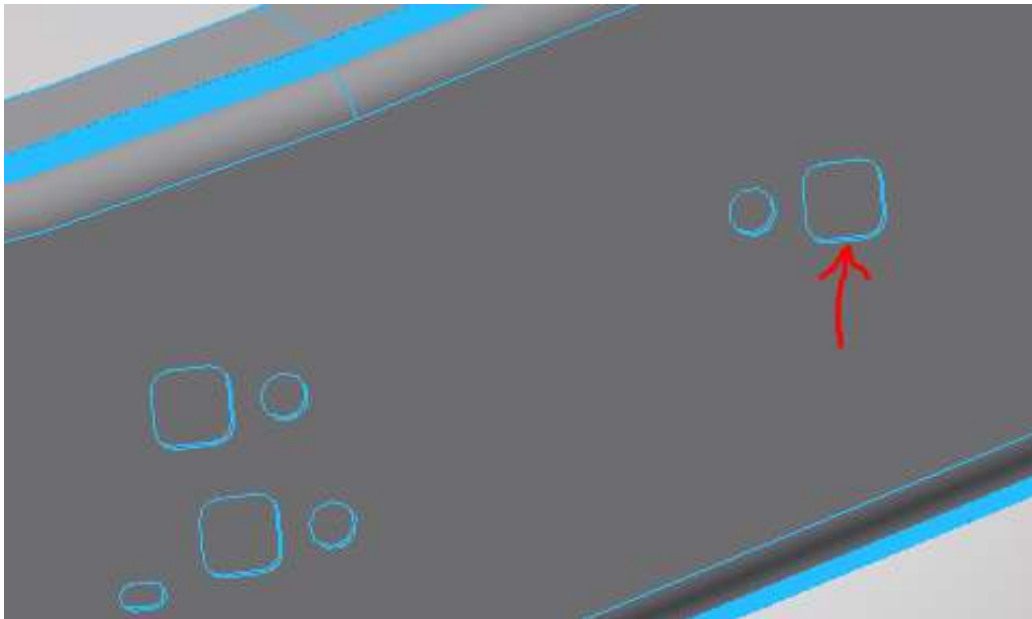

Figure 5

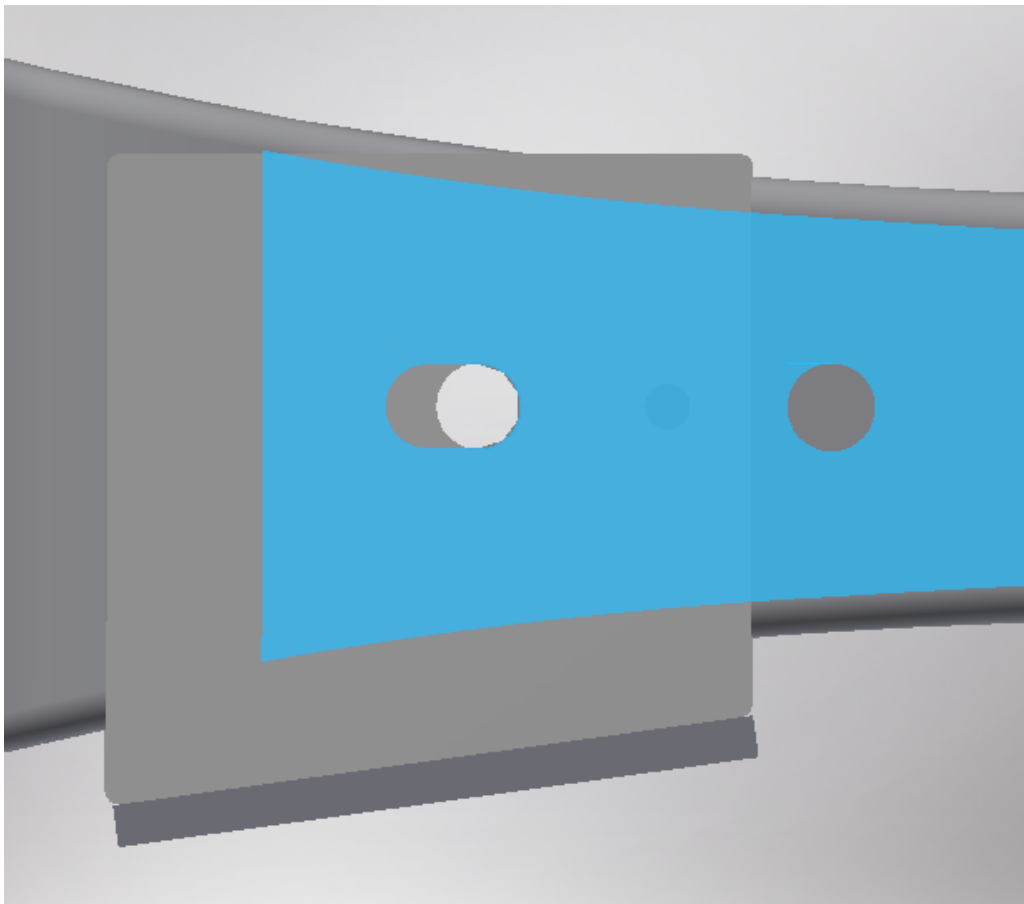

Figure 6



Figure 7

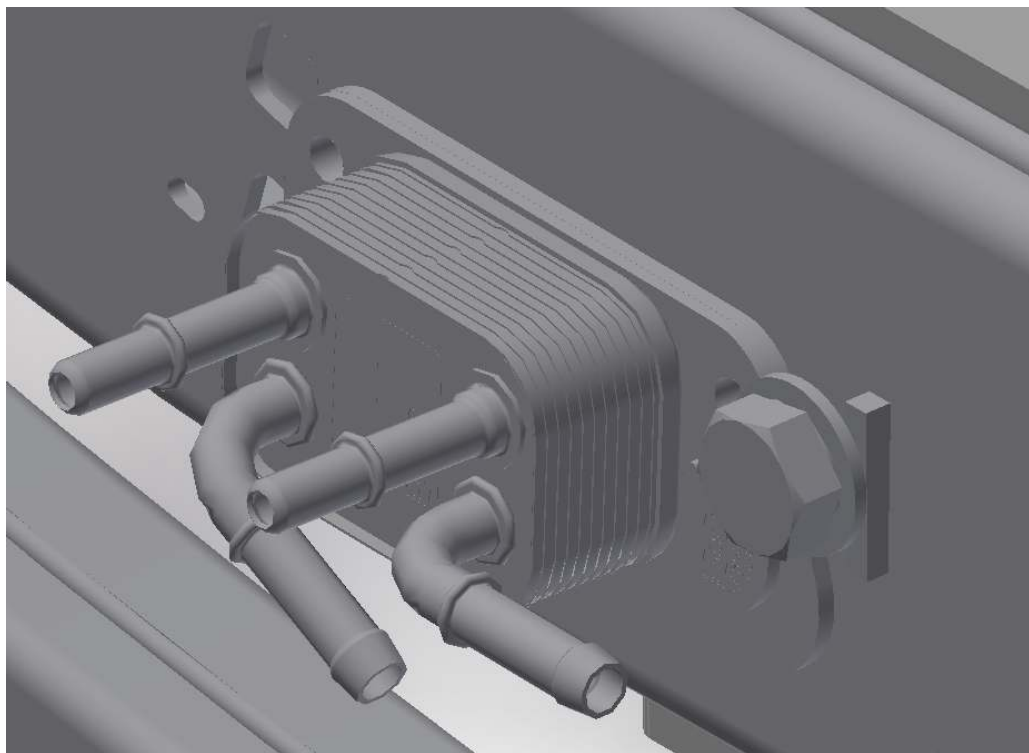

Figure 8

OPERATION SAFETY PRECAUTIONS

If any operating, service or parts problems are encountered, please call G&B Specialties, Inc. for technical assistance.



- Failure to heed to any of the following warnings could result in severe bodily injury and/or equipment damage.
- Read and understand this manual completely before attempting operation of the railgear equipped vehicle.
- Operating instructions provided below only address the Rafna railgear equipment. Applicable railway company procedures and policies must be adhered to.
- Railway Company rules governing rail travel must be observed at all times.
- Before performing any work under the vehicle or railgear, ensure the engine is turned off and the parking brake is set.
- Ensure all removed components are given to the vehicle owner after the installation of the railgear. These components must be re-installed if the railgear is removed from the vehicle.
- Always disconnect the vehicle's battery when welding on the vehicle or railgear in order to protect the vehicle's electrical system.

ROD OPERATED FRONT AXLE LOCK OPERATION

With the Front Axle Lock kit installed on this vehicle, it may be operated as normal.

Never operate the vehicle if the Gross Vehicle Weight Rating (GVWR), Gross Axle Weight Rating Front or Rear (GAWR), or the wheel or tire load ratings are exceeded.

Refer to the Railgear Kit Operation, Service and Parts manual for information on the mechanical operation, service, and parts of the railgear.

PLACING VEHICLE ON RAIL

1. Grasp the handle for the axle lock rod (one for each side), pull the pin and push the rod in toward the front bumper. Insert pin to lock in place.
2. Visually inspect that both axle lock-up hooks have fully engaged the hook catches welded to the front suspension arms.
3. Proceed to lower the front railgear unit.
4. As the front rail wheels engage the rail, the front of the vehicle will begin to rise.
5. Continue to lower the front railgear unit until the cylinders are fully extended and the railgear lock up hook has engaged.
6. With the front railgear unit in the fully locked rail position, the front tires should be minimally 1.5" or otherwise specified above the rail head.

REMOVING VEHICLE FROM RAIL

1. Disengage the railgear lock and raise the railgear to the full locked road position.
2. Grasp the handle for the axle lock rod (one for each side), pull the pin and pull the rod out away the front bumper. Insert pin to lock in place.
3. Visually inspect that both axle lock-up hooks have fully retracted from the hook catches welded to the front suspension arms.

ROD OPERATED FRONT AXLE LOCK ADJUSTMENT

The manual front axle lock is adjusted when the vehicle is resting on its tires in its minimum loaded condition with the railgear in the **road** position and the axle lock engaged. For the axle lock to function properly, there are three adjustments to be made:

1. There should be a clearance of 1/8" to 3/8" between the hooking surface of each hook and hook catch. If the clearance is larger than 3/8", steel shims can be welded to the bottom of the hook catch. If the clearance is less than 1/8", any previously installed shims can be removed. If there are no shims to remove, the hook catch can be cut off the bracket and re-welded higher up on the bracket using a 3/8" all around fillet weld.
2. The rear vertical edge of each hook should rest flat against the forward edge of the hook catch when the axle lock is fully engaged. This can be adjusted by cutting the hook catch off the bracket and re-welding it in place using a 3/8" all around fillet weld.

3. Each hook must clear the suspension arm by at least 1/2" through its full range of motion. The hooks can be moved inboard and outboard on the hook hanger pivot post by adjusting the number of plastic washers on each side of the hook.
4. Paint all welded areas after the axle lock is properly adjusted.
5. Ensure that there is sufficient clearance between the front axle lock components and all vehicle components through their full range of motion.

SERVICE OF ROD OPERATED AXLE LOCK KIT

The Axle Lock kit must be serviced regularly to avoid damage to the equipment. Table 1 below provides the Recommended Service Schedule and Table 2 provides Standard Fastener Torque Values.

Table 1: Recommended Service Schedule

Service Required	Daily	Weekly	Monthly	3 Months	6 Months
Inspect front axle lock fasteners (re-torque if required)	✓	✓	✓	✓	✓
Check / adjust front axle lock hook clearance (see procedure)					✓

Table 2: Standard Fastener Torque Values

Fastener Size	Fastener Torque Value (ft-lbs) Dry
1" UNC Gr. 8 Fasteners	250
¾" UNC Gr. 8 Fasteners	175
5/8" UNC Gr. 8 Fasteners	150
½" UNC Gr. 8 Fasteners	100
3/8" UNC Gr. 8 Fasteners	40
¼" UNC Gr. 8 Fasteners	12

INSTALLATION OF CABLE OPERATED FRONT AXLE LOCK KIT

The following procedure details the installation of the Cable Operated Front Axle Lock Kit. The hardware required for this installation is listed in the table below.

Table 1: K-R46AVXFX05/K-R46AVXFX23 (R-450 Cable Operated Front Axle Lock Kit)

Part Number	Description	Qty
R-12029D	L-Bracket Weldment Drivers Side	1
R-12029P	L-bracket Weldment Passengers Side	1
R-5653	Insulator Washer	4
R-4912-A	Hook	2
R-12018	Spacer	2
R-12031	Support Bracket	2
R-4911	Bracket (FOR MY 17-22 VEHICLES)	2
R-4923	Bracket (FOR MY 23 & UP VEHICLES)	2
R-4914	Hook Catch	2
R-20319	Support Bracket, Pull Cable DS	1
R-20319P	Support Bracket, Pull Cable PS	1
R-20150	Clevis	2
R-20143	Pin, Clevis	2
R-12032	Washer, Fuel Cooler Spacer	1
R-20320	Clevis Tab	2
R-20325	Cable, Pull	2
P-00014	Bolt, Adaptor	2
P-00018D	Mounting Bracket, Pull Cable, Drivers Side	1
P-00018P	Mounting Bracket, Pull Cable, Passengers Side	1
R-33285	Bumper Spacer	4
990727-150-22	Screw, 1/2" x 1 1/2" Gr. 8 H.H.C.S.	8
990316-050-22	Nut, 1/2" Gr. 8 Hex Nylock Z/Y	8
R-LABEL001	Pull to Unlock Placard	2
990506-100-02	Cotter Pin, 1/8" x 1" Z/Y	2
990600-050-002	Washer, 1/2" Flat Z/Y	18
990310-050-22F	Nut, 1/2"-20 Gr. 8 Hex Jam Z/Y	2
R-990KIT-277	Nut, 1/2" Gr. 8 Hex Nylock Z/Y	10
	Washer, 1/2" Flat Z/Y	20
	Screw, 1/2" x 3 1/2" Gr. 8 H.H.C.S.	8
	Screw, 1/2" x 3 1/4" Gr. 8 H.H.C.S.	2
R-990KIT-116A	Screw, 3/8" x 4" Gr. 8 H.H.C.S.	2
	Washer, 3/8" Flat Z/Y	6
	Nut, 3/8" Gr. 8 Hex Nylock Z/Y	4
	Washer, 1/2" Flat Z/Y	8
	Screw, 3/4" x 5" Gr. 8 H.H.C.S.	2
	Screw, 3/4" x 5 1/2" Gr. 8 H.H.C.S.	2
	Nut, 1/2" Gr. 8 Hex Nylock Z/Y	2
	Washer, 3/4" Flat Z/Y	10
	Nut, 3/4" Gr. 8 Hex Nylock Z/Y	6
	Washer, 1/4" Flat Z/Y	2
	Nut, 1/4" Gr. 8 Hex Nylock Z/Y	2
	Cotter Pin, 1/8" x 2" Z/Y	2

The front axle lock kit is to be positioned just rearward of the vehicle's front suspension springs. Mounting holes in the hook hanger and bracket will align with some existing holes in the vehicle frame and suspension arm, respectively. The axle lock hook is designed to swing toward the front of the vehicle while disengaged for the road position and toward the rear of the vehicle while engaged for the rail position. The pull cable is fastened to the hook and routed toward the front of the vehicle to control the hook position.

1. Remove fuel cooler from inside frame. Hoses should not have to be removed, just bolts taken out to be free of the frame. Use one of the existing mounting points for our bracket. Clip will need to be removed from square hole. See (Fig.1) for location.
2. Pop out wiring clips, grounding stud, etc. on top of the frame so that the bracket will sit flat on the frame. A brake clip and a grounding stud are located on the bracket for re-installation. The pop rivet can be removed from the brake clip and installed on the bracket with supplied hardware. See Fig. 2 for clip and pop rivet.
3. Find the slotted hole on top of the frame. Take the bracket R-12029D (Driver's Side) and align the locating slug on the bracket with the slot in the frame. When done correctly, the slug should drop into the slot on the frame and the bracket will sit against the top and outer surfaces of the frame. See (Fig. 3).
4. With the bracket on the frame, center punch the slot on the bracket. Remove the bracket and drill a 49/64" hole. Hole should line up with the existing square hole where we removed the clip from earlier. Check with supplied 3/4" bolt to ensure the bolt sits parallel and is not angled. The hole may need to be reamed to ensure this. The hole on the outside of the frame can also be obtained by drilling the square hole on the inside of the frame through to the outside. The bracket is slotted for this reason. Ensure the bolt sits straight and not on an angle. Once the hole is in place and bolt sits parallel, re-install fuel cooler leaving out the clip we removed. Install bracket to frame, using R-12032 and 3/4" hardware as shown in Fig. 3 & 4. See Fig. 7 for proper install reference. (Passenger side will need the hole drilled through to the inside of the frame. There are no holes present on the passenger side.)
5. On the radius arm, you will see a slotted hole with a hole next to it. Take the R-4911 or R-4923 (Depending on Model Year) and place it on the radius arm with the larger hole in the bracket aligned with the slot, positioned closest to the hole side of the slot. See (Fig.7) Place 3/4" bolt that was supplied through the bracket and radius arm to hold the bracket and with the bracket against the bottom of the radius arm, mark the center of the small hole of the bracket on frame. You may also mark the center of the hole on the inside of the frame. Drill a 13/32" hole through the radius arm, or on the inside and outside where marked. With the hole drilled, install bracket using the 3/4" and 3/8" hardware supplied in kit. See (Fig. 3 & 5) for reference. Ensure not to over-tighten bolts and deform the radius arm.

6. Assemble the hook, R-4912-A, and bracket, R-12031, onto the all thread stud as shown in Fig. 4. If lateral adjustment is required, the supplied spacer can be trimmed down, or washers can be added into assembly to maintain proper clearance with the frame, suspension arm, and hook. Nylock nut should be tightened enough to secure hook, but not hinder it from swinging.
7. Position each clevis tab, R-20320, (Approximately) before the 3” radius on hook (Adjustment may need to be made to ensure proper function, see Fig. 6). Tack weld each tab to each hook temporarily.
8. Install the actuating cables for the axle lockup as shown (Fig. 6). Run cable through bracket, R-20319, and adjust position on R-12301. Once in place, tighten jam nuts on the pull cable and tack R-20319 to R-12301. (A C-Clamp may also be used for testing purposes) Test the pull cable to ensure when pulled, the hook will follow accordingly. Adjustment may need to be made to R-20319. Once functioning properly, weld permanent R-20319 to R-12301 and the clevis tab. (For Passenger’s Side R-20319P will be used) Route cables to the front of the vehicle and select a proper mounting location for the pull cable mounting brackets. Brackets can be located anywhere accessible in a location that will keep the end user away from harm. This will be based on installers discretion.

Do not install the hook catch or make any adjustment to the lockup hook engagement until all the vehicle’s permanent load has been installed as the vehicle equipment will affect the vehicles ride height and therefore the axle lock hook engagement.

9. Position each hook so that it is hanging vertically with the hooking surface horizontal. Position each hook catch on each bracket, as shown, so that the vertical side of the hook just touches the forward-most part of the hook catch and there is a minimal gap between the bottom of the hook catch and the hooking surface. Tack weld each hook catch to each bracket.
10. With the axle lock-up cables installed, engage the lock-up so that both cables are fully extended. Ensure that the hook will fully engage the hook catch. If the hook/hook catch engagement needs to be adjusted; the hook catch can be removed and tack welded in a different location. The engagement can also be adjusted by loosening the 1/2” jam nut on the adapter bolt and adjusting the adapter bolt in or out to increase or decrease the engagement. Tighten jam nut.
11. Ensure that there is sufficient clearance between the front axle lock components and all vehicle components through their full range of motion.
12. Fully weld the hook catch to the suspension arm bracket.
13. Paint all areas that were welded or heated.
14. Test the operation of the front axle lock.

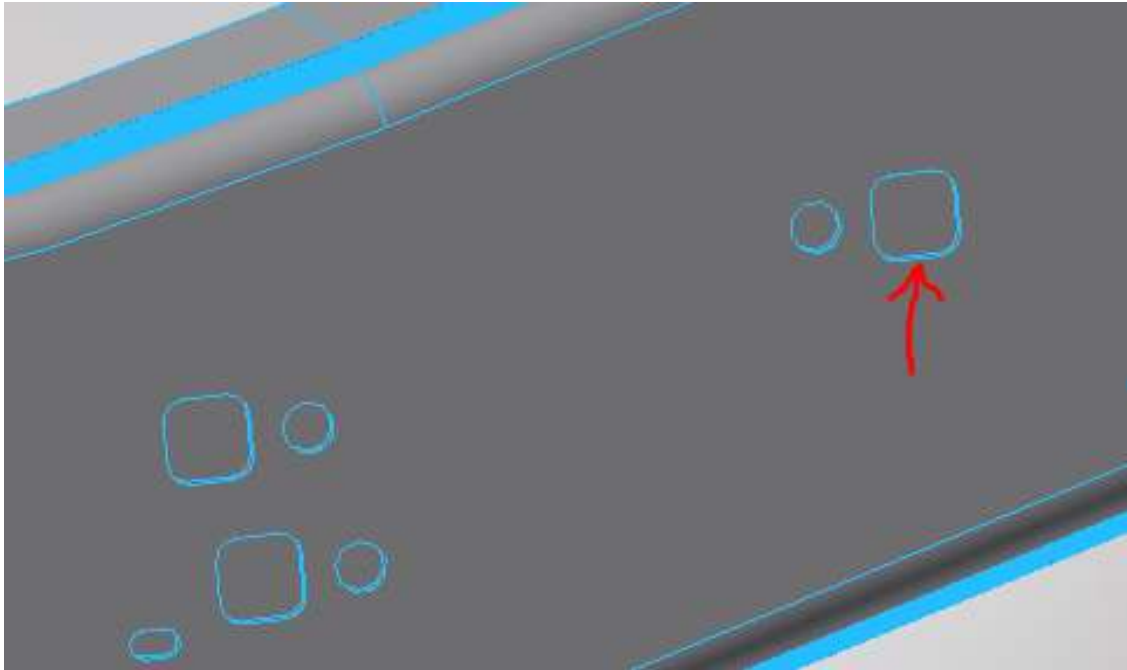
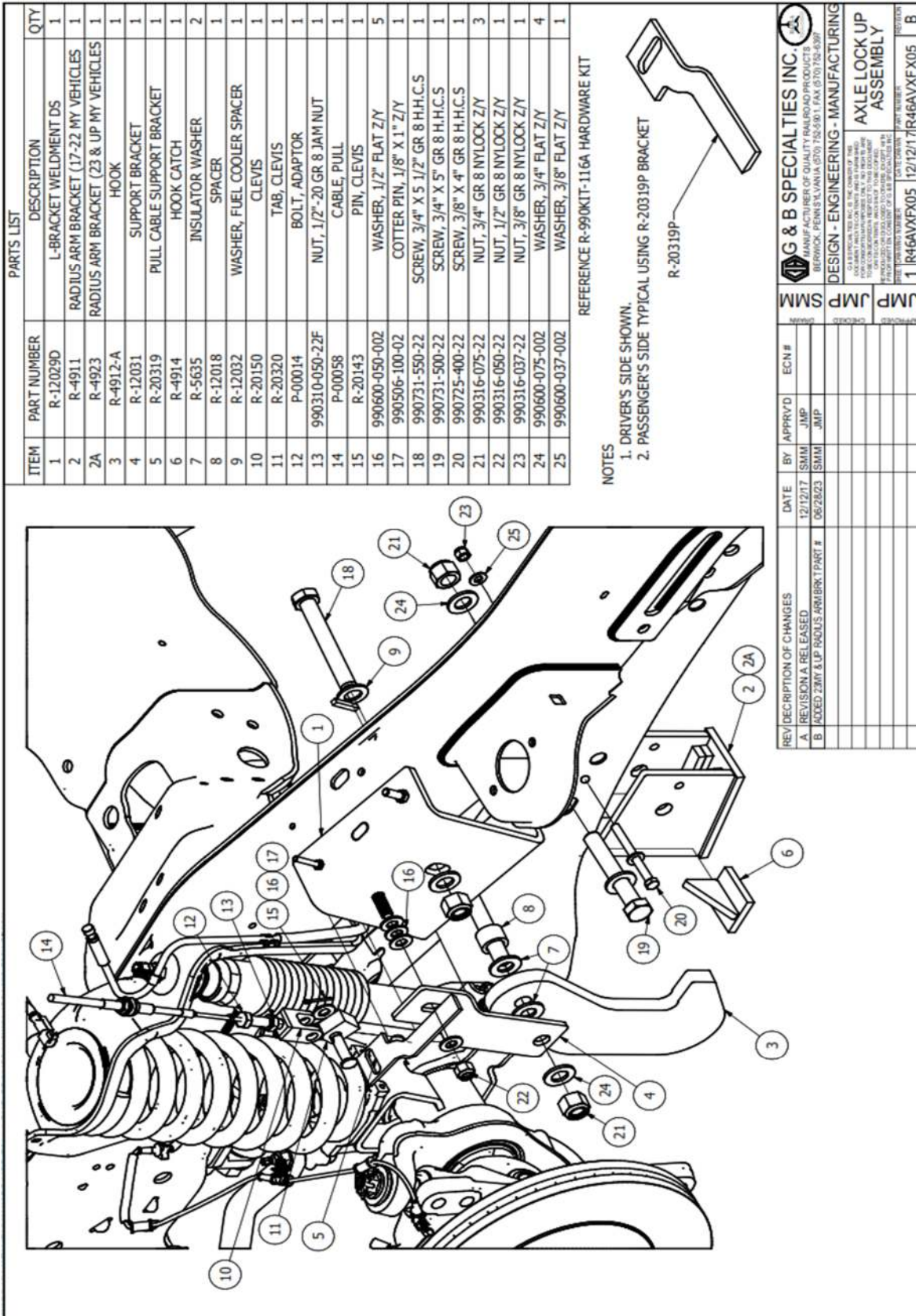

Figure 1



Figure 2



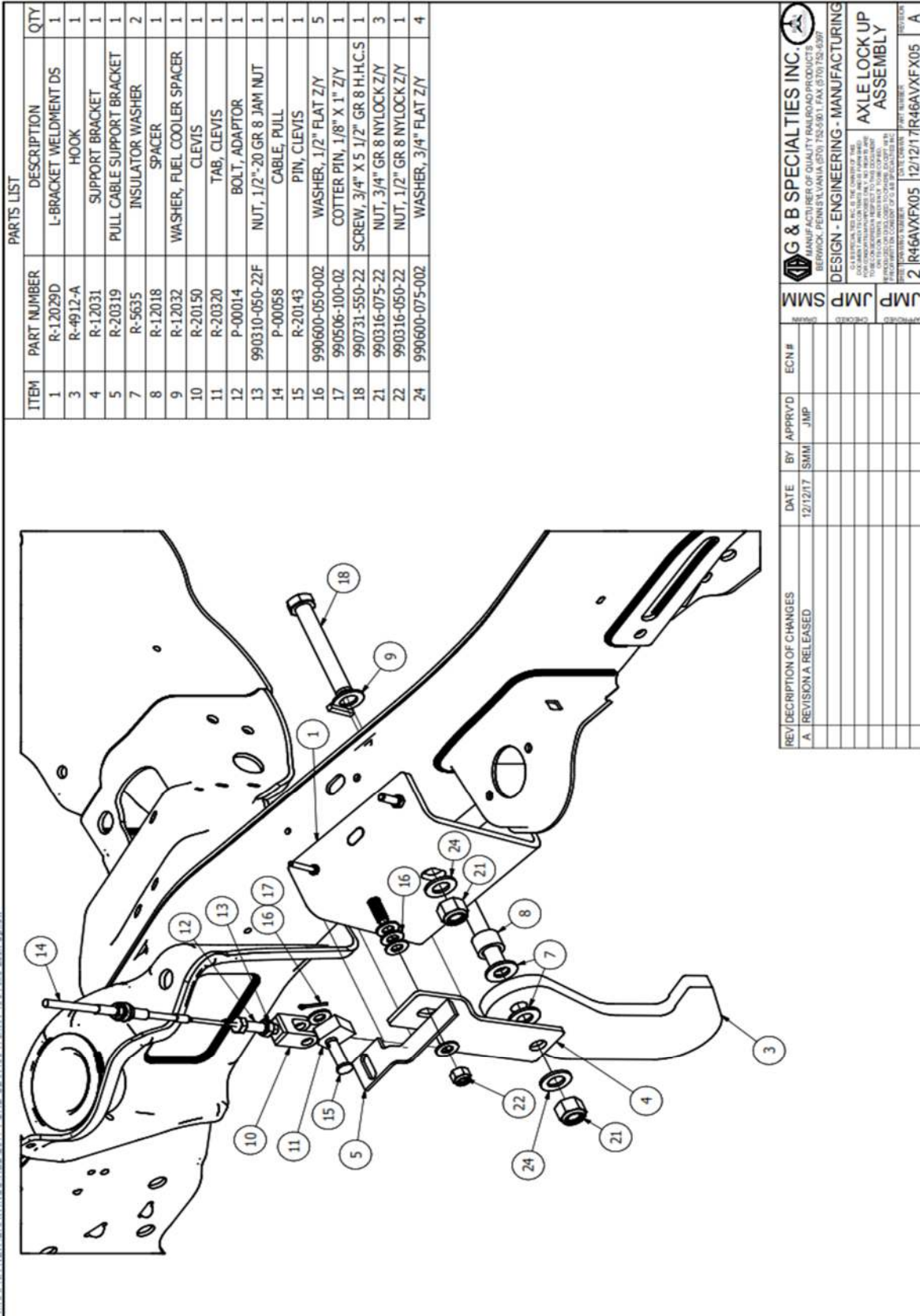

Figure 4

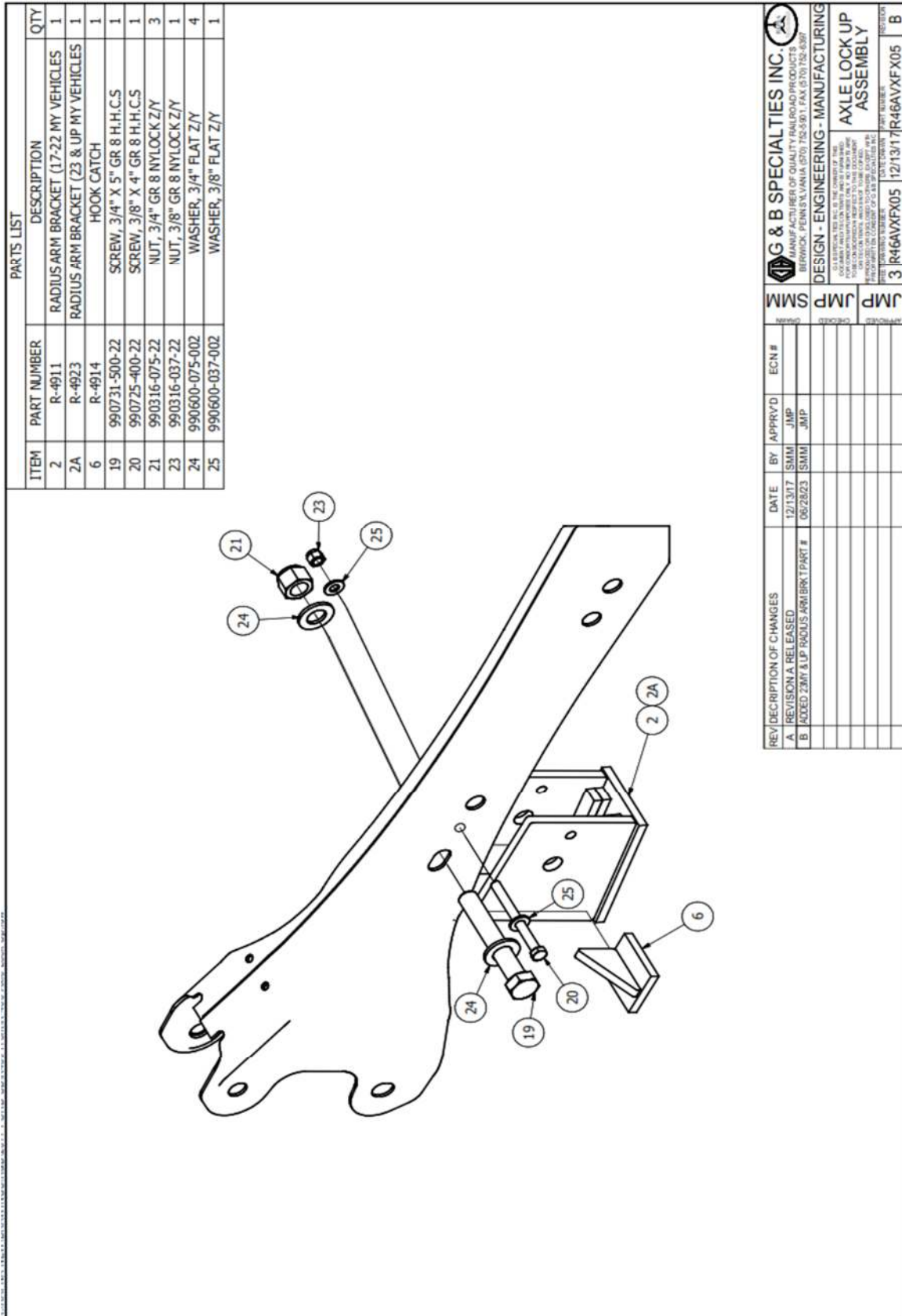

Figure 5

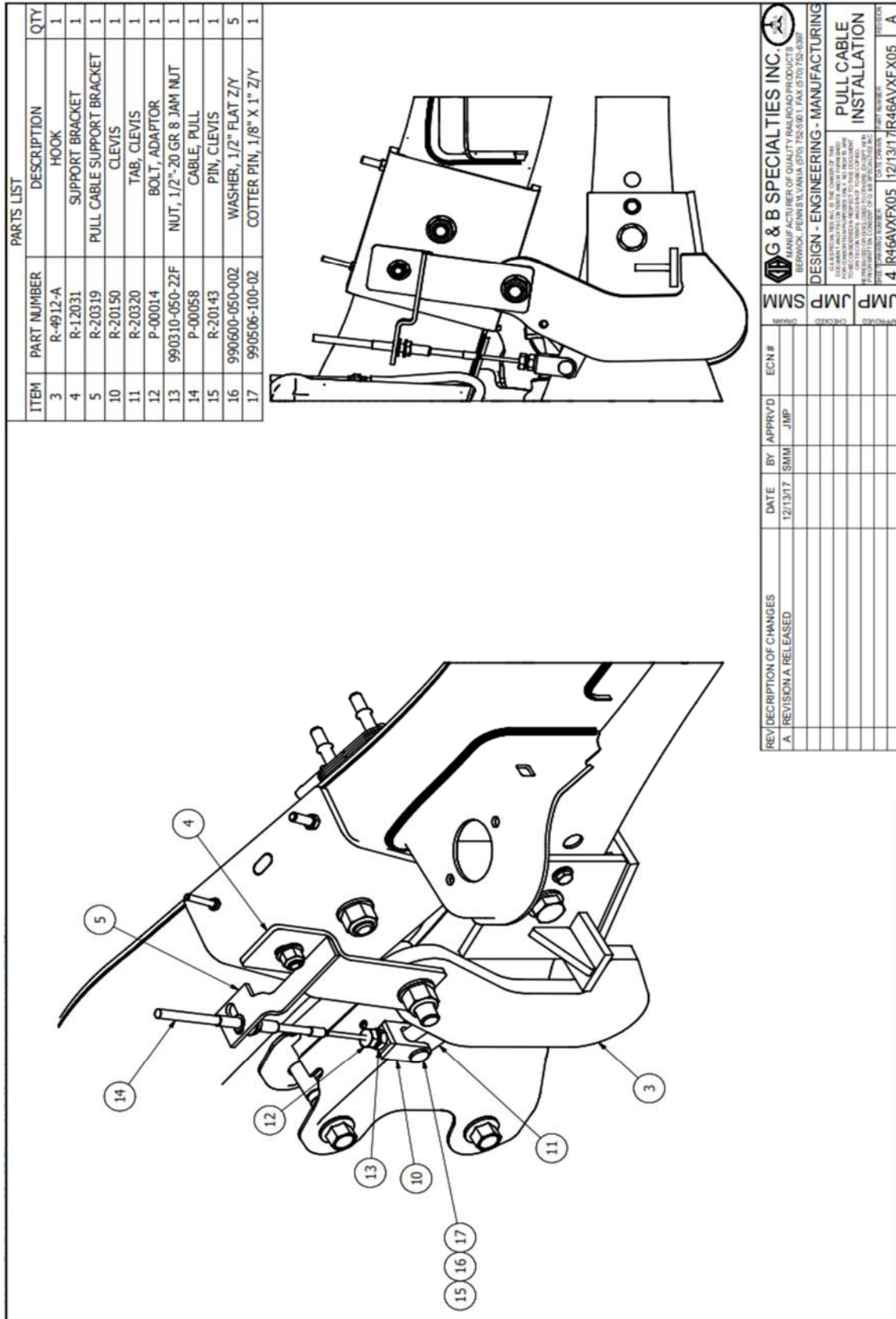

Figure 6

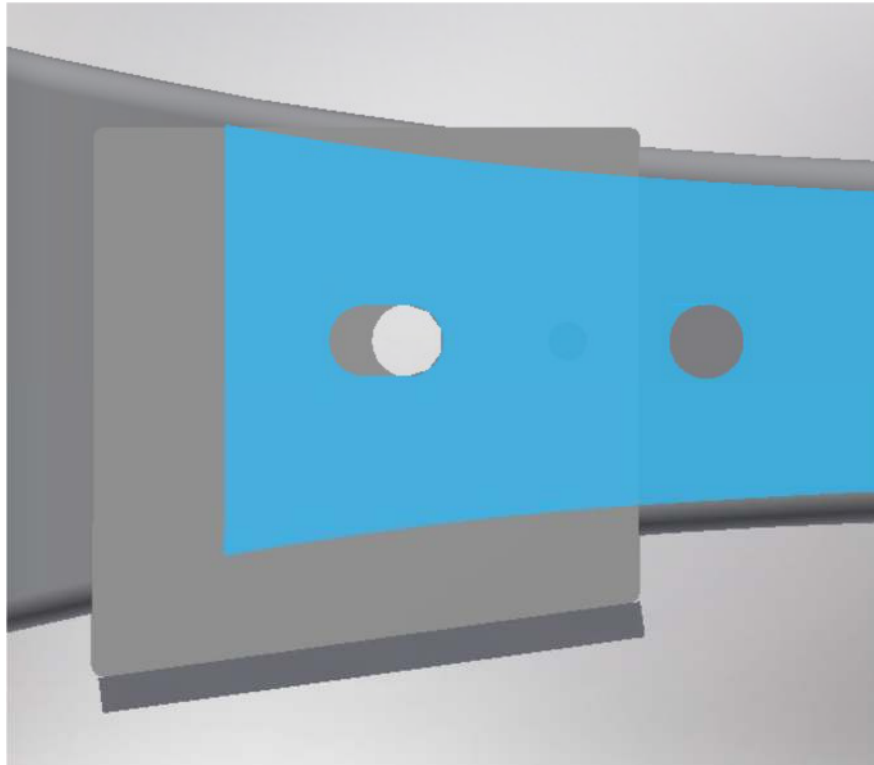

Figure 7

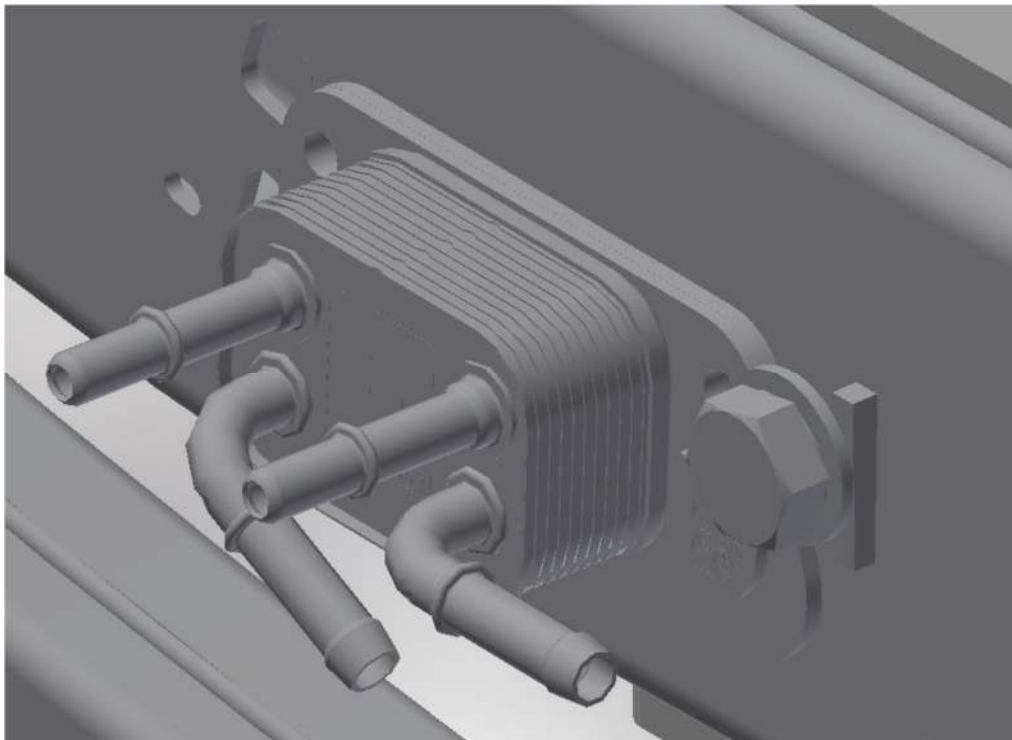

Figure 8

OPERATION SAFETY PRECAUTIONS

If any operating, service or parts problems are encountered, please call G&B Specialties, Inc. for technical assistance.



- Failure to heed to any of the following warnings could result in severe bodily injury and/or equipment damage.
- Read and understand this manual completely before attempting operation of the railgear equipped vehicle.
- Operating instructions provided below only address the Rafna railgear equipment. Applicable railway company procedures and policies must be adhered to.
- Railway Company rules governing rail travel must be observed at all times.
- Before performing any work under the vehicle or railgear, ensure the engine is turned off and the parking brake is set.
- Ensure all removed components are given to the vehicle owner after the installation of the railgear. These components must be re-installed if the railgear is removed from the vehicle.
- Always disconnect the vehicle's battery when welding on the vehicle or railgear in order to protect the vehicle's electrical system.

CABLE OPERATED FRONT AXLE LOCK OPERATION

With the Front Axle Lock kit installed on this vehicle, it may be operated as normal.

Never operate the vehicle if the Gross Vehicle Weight Rating (GVWR), Gross Axle Weight Rating Front or Rear (GAWR), or the wheel or tire load ratings are exceeded.

Refer to the Railgear Kit Operation, Service and Parts manual for information on the mechanical operation, service and parts of the railgear.

PLACING VEHICLE ON RAIL

1. Grasp the handle for the axle lock cable (one for each side), twist handle to unlock and push the cable in toward the front bumper. Twist the handle again to lock in place.
2. Visually inspect that both axle lock-up hooks have fully engaged the hook catches welded to the front suspension arms.
3. Proceed to lower the front railgear unit.
4. As the front rail wheels engage the rail, the front of the vehicle will begin to rise.
5. Continue to lower the front railgear unit until the cylinders are fully extended and the railgear lock up hook has engaged.
6. With the front railgear unit in the fully locked rail position, the front tires should be minimally 1.5" or otherwise specified above the rail head.

REMOVING VEHICLE FROM RAIL

1. Disengage the railgear lock and raise the railgear to the full locked road position.
2. Grasp the handle for the axle lock cable (one for each side), twist handle to unlock and pull the cable out away the front bumper. Twist the handle again to lock in place.
3. Visually inspect that both axle lock-up hooks have fully retracted from the hook catches welded to the front suspension arms.

CABLE OPERATED FRONT AXLE LOCK ADJUSTMENT

The manual front axle lock is adjusted when the vehicle is resting on its tires in its minimum loaded condition with the railgear in the **road** position and the axle lock engaged. For the axle lock to function properly there are three adjustments to be made:

1. There should be a clearance of 1/8" to 3/8" between the hooking surface of each hook and hook catch. If the clearance is larger than 3/8", steel shims can be welded to the bottom of the hook catch. If the clearance is less than 1/8", any previously installed shims can be removed. If there are no shims to remove, the hook catch can be cut off the bracket and re-welded higher up on the bracket using a 3/8" all around fillet weld.
2. The rear vertical edge of each hook should rest flat against the forward edge of the hook catch when the axle lock is fully engaged. This can be adjusted by cutting the hook catch off the bracket and re-welding it in place using a 3/8" all around fillet weld.

3. Each hook must clear the suspension arm by at least 1/2" through its full range of motion. The hooks can be moved inboard and outboard on the hook hanger pivot post by adjusting the number of plastic washers on each side of the hook.
4. Paint all welded areas after the axle lock is properly adjusted.
5. Ensure that there is sufficient clearance between the front axle lock components and all vehicle components through their full range of motion.

SERVICE OF CABLE OPERATED AXLE LOCK KIT

The Axle Lock kit must be serviced regularly to avoid damage to the equipment. Table 1 below provides the Recommended Service Schedule and Table 2 provides Standard Fastener Torque Values.

Table 1: Recommended Service Schedule

Service Required	Daily	Weekly	Monthly	3 Months	6 Months
Inspect front axle lock fasteners (re-torque if required)	✓	✓	✓	✓	✓
Check / adjust front axle lock hook clearance (see procedure)					✓

Table 2: Standard Fastener Torque Values

Fastener Size	Fastener Torque Value (ft-lbs) Dry
1" UNC Gr. 8 Fasteners	250
¾" UNC Gr. 8 Fasteners	175
5/8" UNC Gr. 8 Fasteners	150
½" UNC Gr. 8 Fasteners	100
3/8" UNC Gr. 8 Fasteners	40
¼" UNC Gr. 8 Fasteners	12

INSTALLATION OF HYDRAULIC OPERATED FRONT AXLE LOCK KIT

The following procedure details the installation of the Hydraulic Operated Front Axle Lock Kit. The hardware required for this installation is listed in the table below.

Table 1: K-R45AVXFX006/K-R45AVXFX23H (R-450 Hydraulic Front Axle Lock Kit)

Part Number	Description	# Req.
R-12029D	L-Bracket Weldment Drivers Side	1
R-12029P	L-Bracket Weldment Passengers Side	1
R-5635	Insulator Washer	4
R-12018	Spacer	2
R-12034D	Brkt Assy DS, Hydraulic Support	1
R-12034P	Brkt Assy PS, Hydraulic Support	1
R-4911	Bracket (FOR MY 17-22 VEHICLES)	2
R-4923	Bracket (FOR MY 23 & UP VEHICLES)	2
R-4914	Hook Catch	2
R-12032	Washer, Fuel Cooler Spacer	1
R-18072C	Cylinder, Lockup	2
R-12035	Spacer, Cylinder	2
R-12040	Clevis, Cylinder	2
R-12041D	DS Hook, Hydraulic Axle Lockup	1
R-12041P	PS Hook, Hydraulic Axle Lockup	1
R-20161C	Fitting, 45 Elbow 1/4" JIC x 1/4" ORB	2
R-20161A	Fitting, 90 Elbow 1/4" JIC x 1/4" ORB	2
R-12043	Railgear Decal	1
R-12043A	Axle Lock Decal	1
R-990KIT-116AHYD	Washer, 1/4"	1
	Nylock Nut, UNC, 1/4"	1
	Hex Screw, UNC, 3/8" X 4" Lg	2
	Washer, SAE, 3/8"	13
	Nylock Nut, UNC, 3/8"	5
	Jam Nut, UNF, 7/16"	2
	Hex Screw, UNC, 1/2" X 2 1/4" Lg	2
	Washer, 1/2"	14
	Nylock Nut, UNC, 1/2"	4
	Hex Screw, UNC, 3/4" X 5" Lg	2
	Hex Screw, UNC, 3/4" X 5 1/2" Lg	2
	Washer, 3/4"	10
	Nylock Nut, UNC, 3/4"	6

The hydraulic front axle lock-up kit is to be positioned just rearward of the vehicle's front suspension springs. Mounting holes in the hook hanger and bracket will align with some existing holes in the vehicle frame and suspension arm, respectively. The axle lock hook is designed to swing toward the front of the vehicle while disengaged for the road position and toward the rear of the vehicle while engaged for the rail position. The cylinder clevis is fastened to the hook and hydraulic hoses routed toward the front of the vehicle to the control valve which controls the hook position.

1. Remove fuel cooler from inside frame. Hoses should not have to be removed, just bolts taken out to be free of the frame. We will be using one of the existing mounting points for our bracket. Clip will need to be removed from square hole. See (Fig.4) for location.
2. Pop out wiring clips, grounding stud, etc. on top of the frame so that the bracket will sit flat on the frame. Brake clip and grounding stud are located on bracket for re-installation. Pop rivet can be removed from brake clip and installed on bracket with supplied hardware. See Fig. 6 for clip and pop rivet.
3. Find the slotted hole on top of the frame. Take bracket R-12029D (Driver's Side) and align the locating slug on the bracket with the slot in the frame. When done correctly, slug should drop into the slot on the frame and the bracket sit against the top and outer surfaces of the frame. See (Fig. 1).
4. With the bracket on the frame, center punch the slot on the bracket. Remove bracket and drill a 49/64" hole. Hole should line up with existing square hole where we removed the clip from earlier. Check with supplied 3/4" bolt to ensure bolt sits parallel and is not angled. Hole may need to be reamed to ensure this. The hole on the outside of the frame can also be obtained by drilling the square hole on the inside of the frame through to the outside. The bracket is slotted for this reason, just ensure bolt sits straight and not on an angle. Once hole is in place and bolt sits parallel, re-install fuel cooler leaving out the clip we removed. Install bracket to frame, using R-12032 and 3/4" hardware as shown in Fig. 1. See Fig. 7 for proper install reference. (Passenger side will need the hole drilled through to the inside of the frame. There are no holes present on the passenger side.)
5. On the radius arm you will see a slotted hole with a hole next to it. Take R-4911 or R-4923 (Depending on Model Year) and place it on the radius arm with the larger hole in the bracket aligned with the slot, positioned closest to the hole side of the slot. See (Fig.5) Place 3/4" bolt that was supplied through the bracket and radius arm to help hold the bracket, and with the bracket against the bottom of the radius arm, mark the center of the small hole of the bracket on frame. You may also mark the center of the hole on the inside of the frame. Drill a 13/32" hole through the radius arm, or on the inside and outside where marked. With hole drilled, install bracket using the 3/4" and 3/8" hardware supplied in kit. See (Fig.1) for reference. Ensure not to over-tighten bolts and deform the radius arm.
6. Assemble the hook, R-12041D, and bracket, R-12034D, onto the all thread and stud as shown in Fig. 1. If lateral adjustment is required supplied spacer can be trimmed down, or washers can be added into assembly to maintain proper clearance with frame, suspension arm, and hook. Nylock nut should be tightened enough to secure hook, but not hinder it from swinging. (R-12041P and R-12034P will be used on Passenger's Side)

7. Once hook is installed, place the hydraulic cylinder spacer (R-12035) onto the threaded rod of the support bracket along with a 3/8" washer supplied in the hardware kit, and slide the hydraulic cylinder (R-18072C) onto the stud. (The washers act as shims, and more washers may need to be added to ensure cylinder sits properly and doesn't bind. A regular 3/8" nut can be used during this process to allow for the nylock to be used during final installation if chosen to do so.) With the cylinder in its extended position, install the 7/16" jam nut on the end of the cylinder along with the cylinder clevis (R-12040). Adjust clevis so that it mates to the welded tab on the hook. Use the 1/2" x 2 1/4" bolt and hardware provided to secure clevis to the hook. (See Fig. 2) At this point, the cylinder should be fixed to the hook, and the hook hanging vertical. Ensure cylinder is on a straight line with mating to the hook, if not, add washers to the inside of the cylinder on the stud to shim it out until it is straight. Once the cylinder is straight, everything can now be tightened and the nylock nut used to secure the cylinder. (NOTE : cylinder will have a slight rotation on stud during operation, do not over-tighten nut)
8. Repeat same process on passenger's side of vehicle.
9. With the brackets and cylinders installed on both sides, install the R-20161A and R-20161C fittings in their proper ports. From here, reference the hydraulic manual included on how to properly hook up the hydraulic axle lock up.
10. Once the hydraulic system is operational, work the hook to ensure proper clearance and function. Make any adjustments, shimming, trimming etc. needed.
11. Extend the cylinder so that each hook is vertical, with the hooking surface horizontal. Position each hook catch (R-4914) on each bracket so that the vertical side of the hook just touches the forward-most part of the hook catch and there is a minimal gap between the bottom of the hook catch and the hooking surface. Weld each hook catch to each bracket using a 3/8" all around fillet weld. (See Fig. 3)
12. Test the stroke of each cylinder to ensure that each hook can be fully engaged and disengaged from the hook catch.
13. Paint all areas that were welded or heated.
14. Ensure that there is sufficient clearance between the front axle lock components and all vehicle components through their full range of motion.
15. Test the operation of the front axle lock.

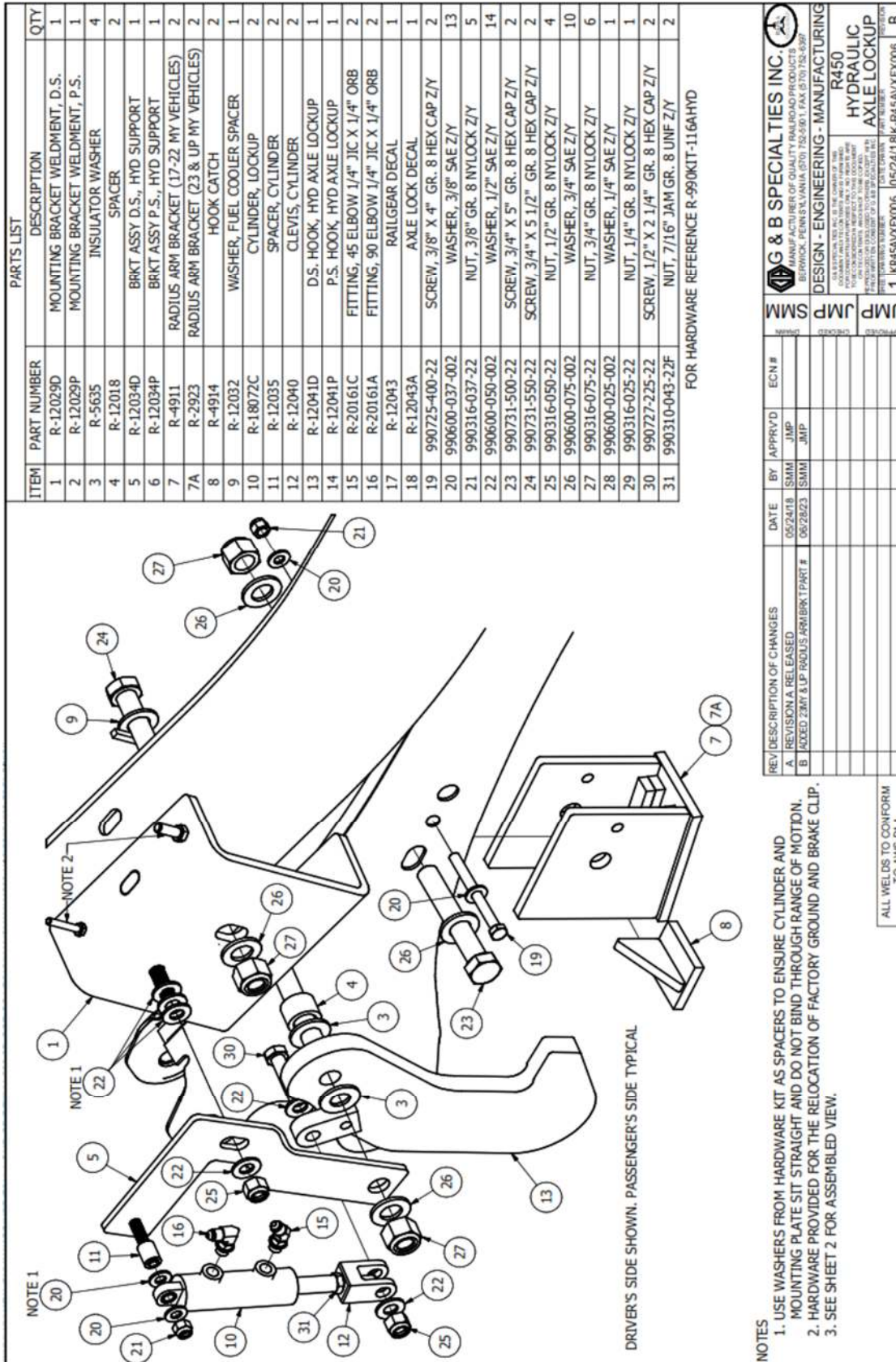

Figure 1

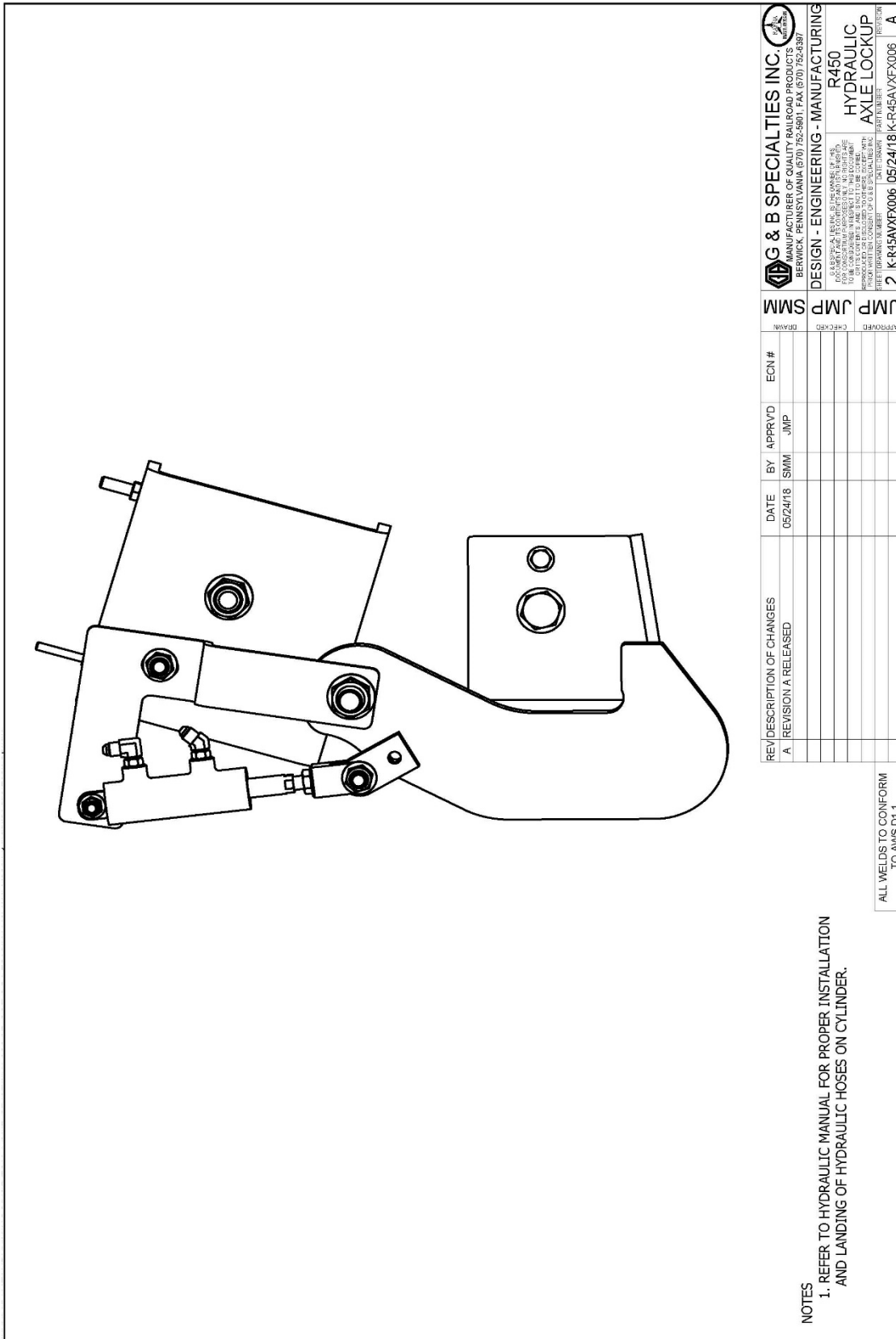

Figure 2

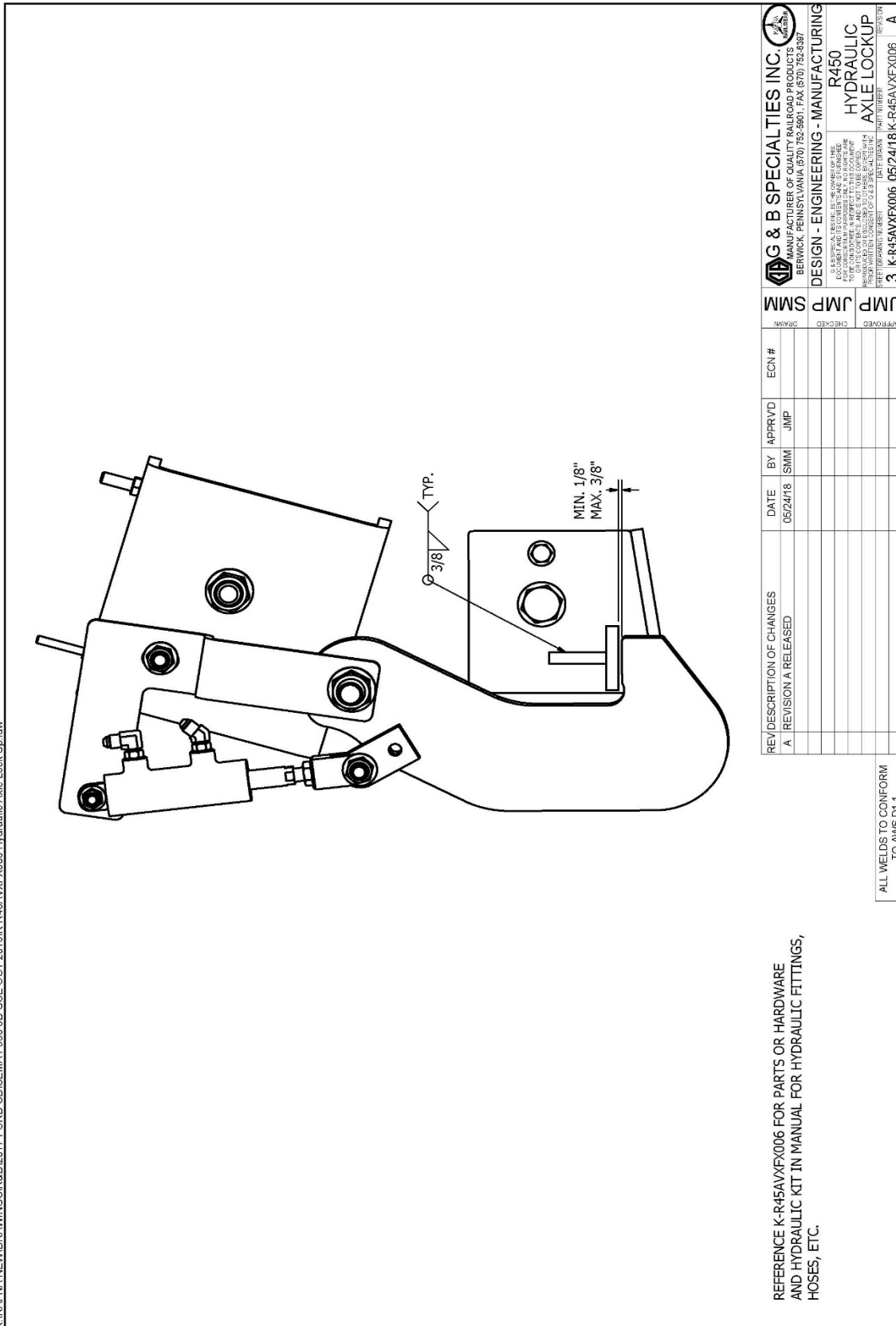

Figure 3

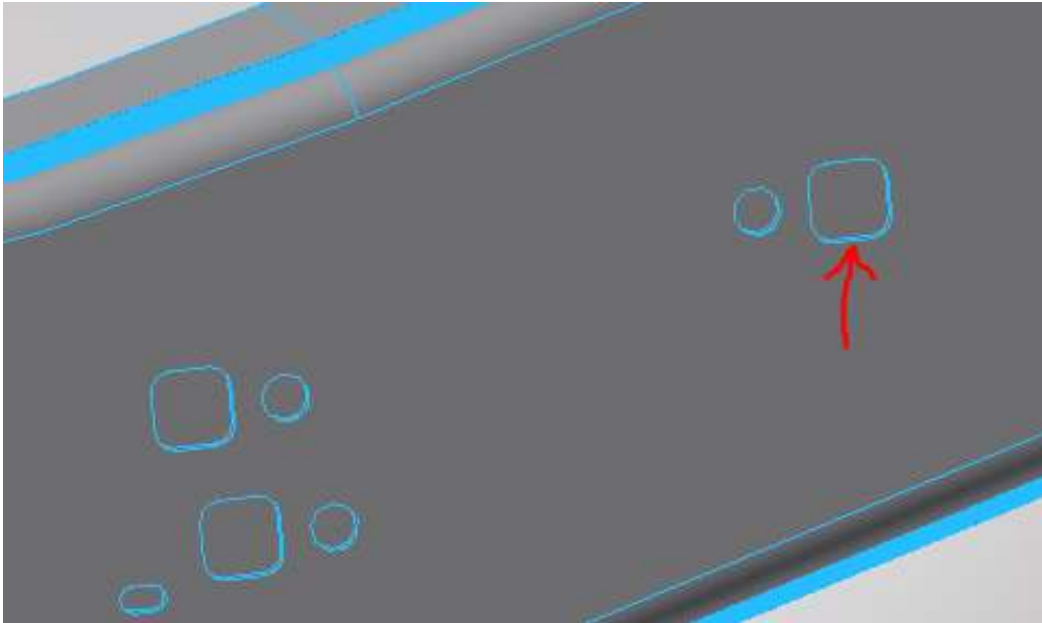

Figure 4

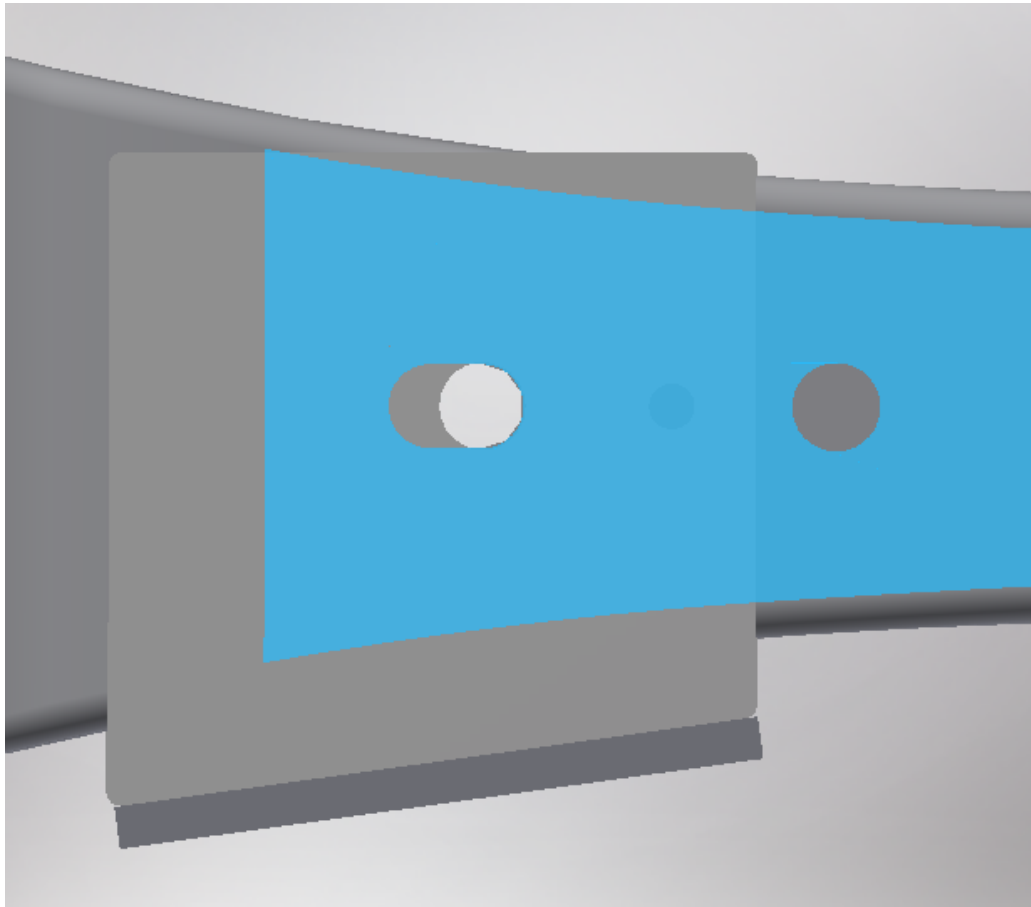

Figure 5



Figure 6

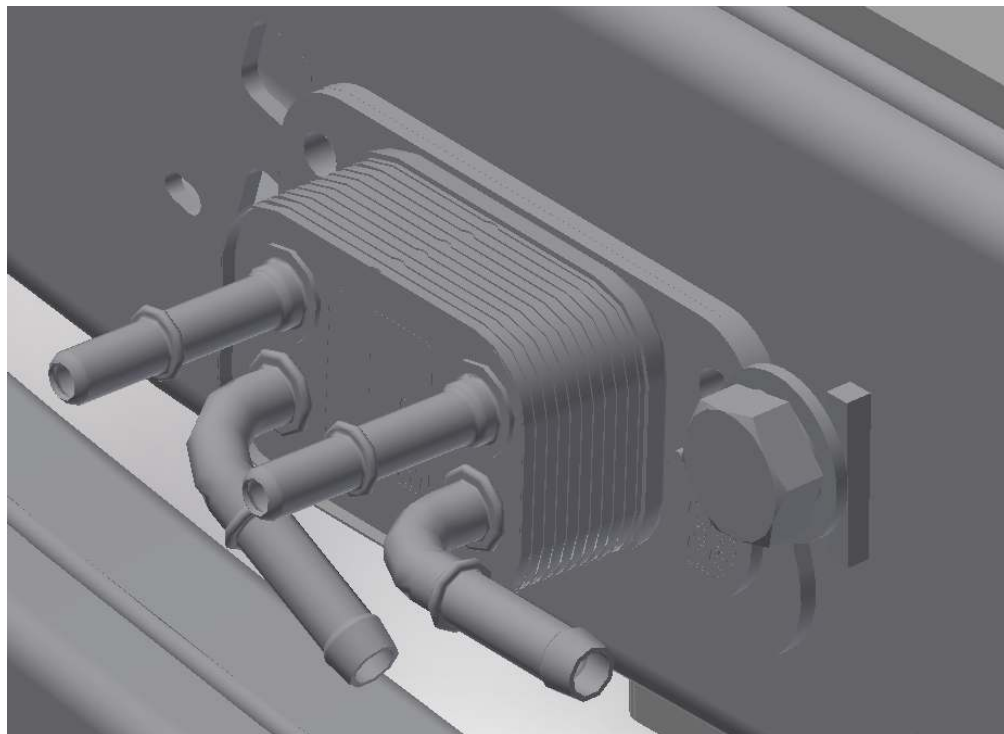

Figure 7

OPERATION SAFETY PRECAUTIONS

If any operating, service or parts problems are encountered, please call G&B Specialties, Inc. for technical assistance.



- Failure to heed to any of the following warnings could result in severe bodily injury and/or equipment damage.
- Read and understand this manual completely before attempting operation of the railgear equipped vehicle.
- Operating instructions provided below only address the Rafna railgear equipment. Applicable railway company procedures and policies must be adhered to.
- Railway Company rules governing rail travel must be observed at all times.
- Before performing any work under the vehicle or railgear, ensure the engine is turned off and the parking brake is set.
- Ensure all removed components are given to the vehicle owner after the installation of the railgear. These components must be re-installed if the railgear is removed from the vehicle.
- Always disconnect the vehicle's battery when welding on the vehicle or railgear in order to protect the vehicle's electrical system.

HYDRAULIC FRONT AXLE LOCK OPERATION

With the Front Axle Lock kit installed on this vehicle, it may be operated as normal.

Never operate the vehicle if the Gross Vehicle Weight Rating (GVWR), Gross Axle Weight Rating Front or Rear (GAWR), or the wheel or tire load ratings are exceeded.

Refer to the Railgear Kit Operation, Service and Parts manual for information on the mechanical operation, service and parts of the railgear.

PLACING VEHICLE ON RAIL

1. Grasp the proper control valve lever for the axle lock-up located at the front of the vehicle. (Lever will control both axle lock-up hooks) Push lever to engage axle lock-up hooks.
2. Visually inspect that both axle lock-up hooks have fully engaged the hook catches welded to the front suspension arms.
3. Proceed to lower the front railgear unit.
4. As the front rail wheels engage the rail, the front of the vehicle will begin to rise.
5. Continue to lower the front railgear unit until the cylinders are fully extended and the railgear lock up hook has engaged.
6. With the front railgear unit in the fully locked rail position, the front tires should be minimally 1.5" or otherwise specified above the rail head.

REMOVING VEHICLE FROM RAIL

1. Disengage the railgear lock and raise the railgear to the full locked road position.
2. Grasp the proper control valve lever for the axle lock-up located at the front of the vehicle. (Lever will control both axle lock-up hooks) Pull lever to disengage axle lock-up hooks.
3. Visually inspect that both axle lock-up hooks have fully retracted from the hook catches welded to the front suspension arms.

HYDRAULIC FRONT AXLE LOCK-UP ADJUSTMENT

The hydraulic front axle lock-up is adjusted when the vehicle is resting on its tires in its minimum loaded condition with the railgear in the **road** position and the axle lock engaged. For the axle lock to function properly, there are three adjustments to be made:

1. There should be a clearance of 1/8" to 3/8" between the hooking surface of each hook and hook catch. If the clearance is larger than 3/8", steel shims can be welded to the bottom of the hook catch. If the clearance is less than 1/8", any previously installed shims can be removed. If there are no shims to remove, the hook catch can be cut off the bracket and re-welded higher up on the bracket using a 3/8" all around fillet weld.
2. The rear vertical edge of each hook should rest flat against the forward edge of the hook catch when the axle lock is fully engaged. This can be adjusted by cutting the hook catch off the bracket and re-welding it in place using a 3/8" all around fillet weld.

3. Each hook must clear the suspension arm by at least 1/2" through its full range of motion. The hooks can be moved inboard and outboard on the hook hanger pivot post by adjusting the number of plastic washers on each side of the hook. The hook can also be adjusted by how far the cylinder clevis is screwed onto the cylinder.
4. Paint all welded areas after the axle lock is properly adjusted.
5. Ensure that there is sufficient clearance between the front axle lock components and all vehicle components through their full range of motion.

SERVICE OF HYDRAULIC FRONT AXLE LOCK KIT

The Axle Lock kit must be serviced regularly to avoid damage to the equipment. Table 1 below provides the Recommended Service Schedule and Table 2 provides Standard Fastener Torque Values.

Table 1: Recommended Service Schedule

Service Required	Daily	Weekly	Monthly	3 Months	6 Months
Inspect front axle lock fasteners (re-torque if required)	✓	✓	✓	✓	✓
Inspect hydraulic fittings and check for hydraulic leaks	✓	✓	✓	✓	✓
Check / adjust front axle lock hook clearance (see procedure)					✓

Table 2: Standard Fastener Torque Value

Fastener Size	Fastener Torque Value (ft-lbs) Dry
1" UNC Gr. 8 Fasteners	250
3/4" UNC Gr. 8 Fasteners	175
5/8" UNC Gr. 8 Fasteners	150
1/2" UNC Gr. 8 Fasteners	100
3/8" UNC Gr. 8 Fasteners	40
1/4" UNC Gr. 8 Fasteners	12

5.0 REAR RAILGEAR KIT

INSTALLATION SAFETY PRECAUTIONS

If any installation problems are encountered, please call G&B Specialties, Inc. for technical assistance before continuing with the installation process.



- Failure to heed to any of the following warnings could result in severe bodily injury and/or equipment damage.
- Read and understand this manual completely before attempting installation and operation of the equipment.
- Installation and operation instructions provided below only address the G&B Specialties railgear equipment. Applicable railway company procedures and policies must be adhered to.
- Before performing any work under the vehicle or railgear, ensure that the engine is turned off and the parking brake is set.
- Beware of all pinch points on the railgear and keep all parts of the body clear.
- Always disconnect the vehicle's battery when welding on the vehicle or railgear in order to protect the vehicle's electrical system.
- Railway company rules governing rail travel must be observed at all times.
- Ensure that the position and function of all railgear controls are known before attempting operation.
- Ensure the railgear is locked in road position before starting road travel.
- Ensure all body parts and loose clothing are clear of any moving parts of the equipment.
- If misalignment of the railgear equipment is indicated, promptly perform the alignment procedure.
- Before performing any work under the vehicle or railgear, ensure the engine is turned off and the parking brake is set.
- Never operate the vehicle if the Gross Vehicle Weight Rating (GVWR), Gross Axle Weight Rating Front or Rear (GAWR), or the wheel or tire load ratings are exceeded.

REAR RAILGEAR KIT

The following procedure details the installation of the rear railgear kit. The hardware required for the different kits are listed in the tables below.

Table 1: K-R45XRFR4836CBL (R-450 Rotating Rear Railgear with Cable Actuated Lock-Up)

Part Number	Description	Qty
R-4836G	Rotating Rear Railgear	1
R-4836GBRZ	Rotating Rear Railgear (Bronze Bushings)	
R-4837E	Axle Lock-up Assembly	1
R-001	10" Wheel Assembly	2
R-4646R	Rail Sweep, Passenger Side	1
R-4646L	Rail Sweep, Driver Side	1
R-4838	Push/Pull Cable	1
S-001031	Railgear Operation Decal	1
R-990KIT-204 Rail Wheel Mounting	1/2" UNC Gr. 8 Bolt x 2.25" Long	8
	1/2" Gr. 8 Washer	16
	1/2" UNC Gr. 8 Nylon Insert Lock Nut	8
R-990KIT-021 Rail Gear Mounting	5/8" UNC Gr. 8 Bolt x 2" Long	6
	5/8" Gr. 8 Washer	12
	5/8" UNC Gr. 8 Nylon Insert Lock Nut	6
	3/4" UNC Gr. 8 Bolt x 2.25" Long	4
	3/4" Gr. 8 Washer	8
	3/4" UNC Gr. 8 Nylon Insert Lock Nut	4

Table 2: K-R45XRFR4836LVR (R-450 Rotating Rear Railgear with Lever Actuated Lock-Up)

Part Number	Description	Qty
R-4836G	Rotating Rear Railgear	1
R-4836GBRZ	Rotating Rear Railgear (Bronze Bushings)	
R-4837B	Axle Lock-up Assembly	1
K-R45XXRX4836	Lever Lock-up Kit	1
R-001	10" Wheel Assembly	2
R-4646R	Rail Sweep Right Side	1
R-4646L	Rail Sweep Left Side	1
S-001031	Railgear Operation Decal	1
R-990KIT-204 Rail Wheel Mounting	1/2" UNC Gr. 8 Bolt x 2.25" Long	8
	1/2" Gr. 8 Washer	16
	1/2" UNC Gr. 8 Nylon Insert Lock Nut	8
R-990KIT-021 Rail Gear Mounting	5/8" UNC Gr. 8 Bolt x 2" Long	6
	5/8" Gr. 8 Washer	12
	5/8" UNC Gr. 8 Nylon Insert Lock Nut	6
	3/4" UNC Gr. 8 Bolt x 2.25" Long	4
	3/4" Gr. 8 Washer	8
	3/4" UNC Gr. 8 Nylon Insert Lock Nut	4

INSTALLATION OF REAR RAILGEAR KIT**Note**

The axle lock-up assemblies for these units has been pre-installed at the factory prior to shipping, it will be necessary to install the push/pull cable or Lever Lock-up Kit during vehicle installation. The procedure for installing the Cable and the Lever Lock-up Kit can be located in the installation section of this manual.

Note:

The following procedure details the installation of the rotating rear railgear kit. The hardware required for each installation is listed in the tables above.

The type of rear lock-up installed on this unit has no effect on installation. The installation procedure below is typical for all R-450 Rotating Rear Units.

1. To install the railgear at the correct height, ensure that the road wheels and tires have been installed on the vehicle and that the vehicle is resting on its properly inflated tires.
2. Position and support the railgear so that the railgear mounting boxes are on either side of the rear of the vehicle frame with the blind end of the hydraulic cylinders facing the rear of the vehicle. The mounting boxes should be flush with the rear of the vehicle frame and fit around the vehicle's suspension hangers. The holes in the mounting boxes should align with existing holes in the vehicle frame. It may be necessary to loosen or remove the 1/2" fasteners that support the railgear lock system to be able to fit the railgear on the frame. Once the railgear is on the frame, tighten and torque the 1/2" fasteners securing the railgear lock system to the railgear to 100 ft-lbs dry. Do not over torque.
3. Ensure that there is approximately 21.5" between the railgear-to-mounting box interface and the ground as shown. If this height cannot be achieved, the vehicle suspension will need to be modified. This modification is not included with the RAFNA railgear.
4. Fasten each railgear mounting box to the vehicle frame using three 5/8" x 2" long bolts, six 5/8" washers and three 5/8" nuts through the existing frame holes at the rear as shown.
5. Using the front-most hole in each railgear mounting box as a guide, drill a 25/32" hole through the vehicle frame.
6. Fasten each railgear mounting box to the vehicle frame using two 3/4" x 2.25" long bolts, four 3/4" washers and two 3/4" nuts through the drilled hole and the existing hole as shown.
7. Torque the 5/8" fasteners to 150 ft-lbs dry and the 3/4" fasteners to 175 ft-lbs dry. Do not over torque.
8. Place the rail wheels below the mounting tables on the railgear axle. Place the rail sweeps to the rear of the rail wheels and on top of the mounting tables. Fasten the rail wheels and rail sweeps to the mounting tables with eight 1/2" x 2.25" long bolts, sixteen 1/2" washers and eight 1/2" nuts.

9. Tighten but do not torque the 1/2" fasteners as they will be torqued following the railgear alignment procedure.

Proceed to install the railgear hydraulic system as per the Hydraulic Kit Installation manual before continuing with the following steps.

10. Follow the Rail Wheel Load Adjustment procedure detailed in the R-450 Rotating Rear Railgear Kit Operation, Service and Parts manual.
11. Follow the Railgear Alignment procedure detailed in the R-450 Rotating Rear Railgear Kit Operation, Service and Parts manual.
12. Follow the Railgear Lock System Installation/Adjustment Procedure detailed in the Railgear Lock System Installation/Adjustment section of this manual.
13. Follow the Rail Sweep Adjustment procedure detailed in the R-450 Rotating Rear Railgear Kit Operation, Service and Parts manual.
14. Torque all fasteners as detailed in the R-450 Rotating Rear Railgear Kit Operation, Service and Parts manual.
15. Grease the railgear at all lubrication points as detailed in the R-450 Rotating Rear Railgear Kit Operation, Service and Parts manual.

ITEM	PART NO.	PART DESCRIPTION	QTY
1	R-4836G	ROTATING REAR RAILGEAR	1
2	R-001	10" WHEEL ASSEMBLY (RIGHT SIDE NOT SHOWN)	2
3	R-4846R	RAIL SWEEP - DRIVER (NOT SHOWN)	1
4	R-4846L	RAIL SWEEP - PASSENGER SIDE	1
5	S-001031	RAILGEAR OPERATION DECAL (NOT SHOWN)	1
6		1/2" UNC GR. 8 BOLT X 2.25" LONG	8
7		1/2" GR. 8 WASHER	16
8		1/2" UNC GR. 8 NYLOCK NUT	8
9		5/8" UNC GR. 8 BOLT X 2" LONG	6
10		5/8" GR. 8 WASHER	12
11		5/8" UNC GR. 8 NYLOCK NUT	6
12		3/4" UNC GR. 8 BOLT X 2.25" LONG	4
13		3/4" GR. 8 WASHER	8
14		3/4" UNC GR. 8 NYLOCK NUT	4
15		VEHICLE FRAME	N/A
	R-4837A	LOCK-UP ASSEMBLY, HYDRAULIC	
	R-4837B	LOCK-UP ASSEMBLY, LEVER	
16	R-4837E	LOCK-UP ASSEMBLY, CABLE	1

NOTE:
1. UNIT SHOWN WITHOUT
LOCK-UP

REV	DESCRIPTION OF CHANGES	DATE	BY	APPRVD	ECN #
A	REVISION A RELEASED	05/07/08	AML		
B	REVISED BILL OF MATERIAL	04/03/18	JEV		

DRAWN	CHECKED	APPROVED	DATE	REVISED	REVISED
AML			05/07/08	04/03/18	

G & B SPECIALTIES INC. MANUFACTURER OF QUALITY RAILROAD PRODUCTS BERWICK, PENNSYLVANIA (570) 752-5901, FAX (570) 752-6397	DESIGN - ENGINEERING - MANUFACTURING	R-450 ROTATING RAILGEAR
<small>FOR ALL INFORMATION CONTACT: G&B SPECIALTIES INC. 535 WEST 3RD STREET, BERWICK, PA 17004-1000. TEL: (570) 752-5901. FAX: (570) 752-6397. WWW.G&BSPECIALTIES.COM. © 2018 G&B SPECIALTIES INC. ALL RIGHTS RESERVED.</small>		PART NUMBER: R-4836G-1 REVISION: B

REAR LOCK-UP CABLE INSTALLATION PROCEDURE

For units equipped with a cable lock-up mechanism, use the following steps to install lock-up:

1. Remove lock-up cover.
2. Install the rear lock cable to the locking system by fastening the end of the cable through the cable support, then thru the pipe on the locking cable bar at the center of the railgear lock system as shown.
3. Fabricate and install a bracket to hold the lock cable handle. Ensure that the handle will be mounted near the railgear controls.
4. Install lock-up cover on rear lock-up assembly. Torque $\frac{1}{4}$ " fasteners to 12 ft-lbs dry.
5. Follow the railgear lock system adjustment procedure.

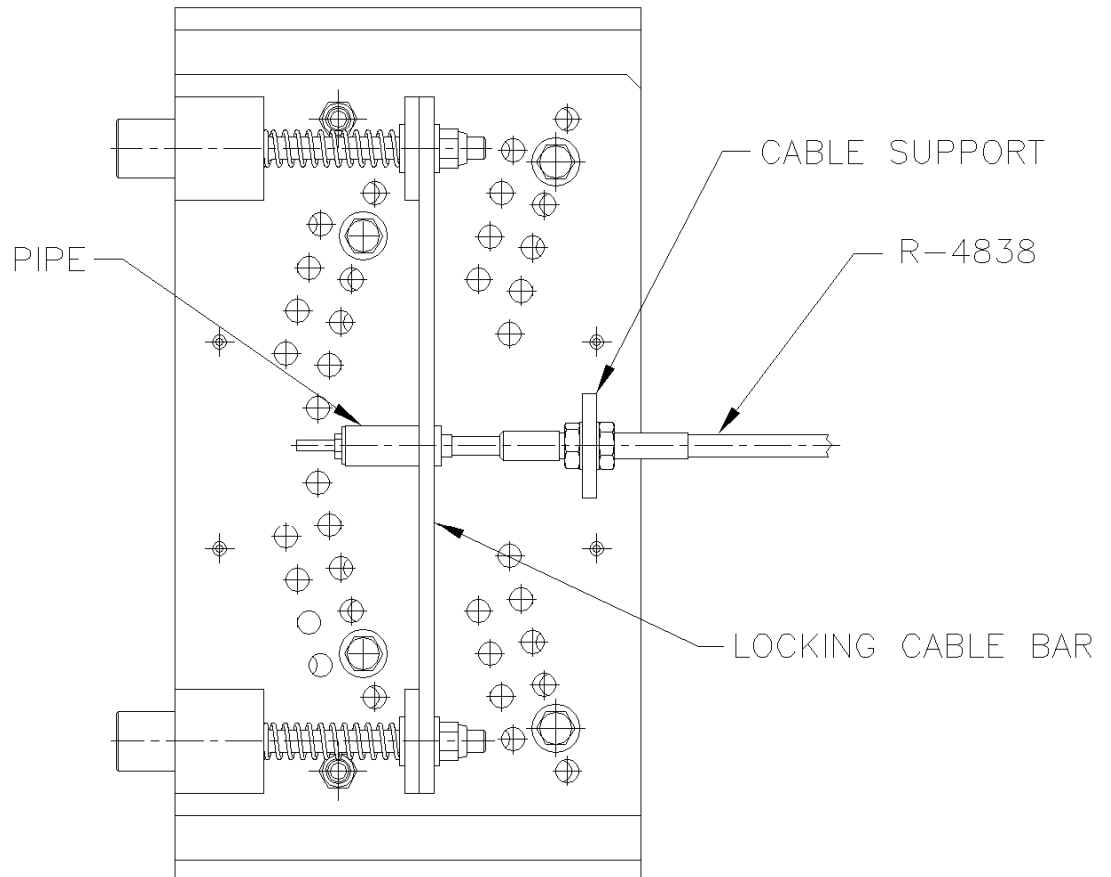

REAR LOCK-UP ASSEMBLY
CABLE ACTUATED

REAR LOCK-UP LEVER INSTALLATION PROCEDURE

For units equipped with a lever lock-up mechanism, use the following steps to install lock-up:

Table 1: K-R45XXRX4836 (R-450 Rotating Rear Manual Lever Lockup Kit)

Part Number	Description	Qty
R-4837B	Axle Lockup Assembly (Assembled on Railgear)	1
R-18109	Rod Support	1
R-18108	Lockup Rod	1
R-18107	Clevis	1
R-18106	Handle	1
R-990KIT-228	1/2"-13 UNC GR.8 Bolt x 3.50" Long	1
	1/2" Flat Washer, Type-A GR. 8	2
	1/2" - 13 UNC Nylock Nut, GR. 8	1
	3/8" Flat Washer, Type-A GR. 8	1
	3/8" - 16 UNC Hex Nut GR. 8	1
	3/8" - 16 UNC Nylock Nut, GR. 8	1

1. Remove lock-up cover.
2. Fasten the clevis (R-18107) to the threaded Lockup Rod (R-18108) with the short-threaded end using a 3/8" hex nut to secure the clevis.
3. Remove the cotter pin on the clevis and clevis pin and fasten the handle (R-18106) to the clevis using the clevis pin and cotter pin that were just removed as shown.
4. Insert the Lockup Rod that is attached to the handle into the spring plate and fasten the handle to the rod support (R-18109) using one 1/2" x 3-1/2" bolt, two 1/2" washers, and a 1/2" nylock nut as shown.

Do not over tighten the nylock nut or the handle will be hard to move or may not move at all. Handle will need to be removed for bending and/or trimming for desired location.

5. Adjust the rod support up or down by loosening the bolts and nuts that hold the rod support so that the handle is parallel with the ground and tighten the 1/2" bolts and nylock nuts that hold the rod support.
6. Place one 3/8" washer and nylock nut on the end of the lockup rod as shown. Use a 5/16 wrench to keep the lockup rod from turning when fastening the nylock nut.
7. Move the handle to the desired location making sure nothing will be in the way when engaging the lockup and tighten the nylock nut so the 3/8" washer is against the spring plate.
8. Test the lockup to ensure proper functionality.
9. Bend and/or trim the handle to desired location.

BILL OF MATERIAL/PARTS LIST			
ITEM	PART NUMBER	DESCRIPTION	QTY
1	-	R-450 ROTATING REAR AXLE LOCKUP ASSEMBLY	REF
2	R-18109	ROD SUPPORT	1
3	R-18108	LOCKUP ROD	1
4	R-18107	CLEVIS	1
5	R-18106	HANDLE	1
6	F WASHER	3/8" TYPE A, GR. 8	1
7	NYLOCK NUT	3/8" UNC, GR.8 STD NYLOCK	1
8	HEX JAM NUT	3/8" UNC, GR.8 STD HEX	1
9	F WASHER	1/2" TYPE A, GR. 8	6
10	NYLOCK NUT	1/2" UNC, GR.8 STD NYLOCK	1
11	H.H.C.S.	1/2" X 3 1/2" LG, UNC, GR. 8	1

G & B SPECIALTIES INC.
1000 W. 10TH STREET
BERWICK, PENNSYLVANIA 17004
TEL: (570) 752-5901 FAX: (570) 752-5937

DESIGN - ENGINEERING - MANUFACTURING
MANUAL LEVER
LOCK-UP
INSTALLATION

DATE: 04/04/08
PART NUMBER: K-R45XXR-X4836
REV: 001

REVISIONS:

REV	DESCRIPTION OF CHANGES	DATE	BY	APPRVD	ECN #
A	REVISION A RELEASED	04/04/08	JMP	SDB	-
B	UPDATED BOM TO MATCH ENGINEERING MASTER	02/28/20	SDB	SDB	-

DATE: 04/04/08
BY: JMP
APPROVED: SDB

DATE: 02/28/20
BY: SDB
APPROVED: SDB

NOTES:

- MANUAL LOCK-UP SHOWN ON DRIVER'S SIDE
- DETAIL A SHOWN FOR CLARITY

ALL WELDS TO CONFORM TO AWS D.1.1

OPERATION SAFETY PRECAUTIONS

If any operating, services or parts problems are encountered, please call G&B Specialties, Inc. for technical assistance.



CAUTION
WARNING

- Failure to heed to any of the following warnings could result in severe bodily injury and/or equipment damage.
- Read and understand this manual completely before attempting operation of the railgear equipped vehicle.
- Operating instructions provided below only address the RAFNA railgear equipment. Applicable railway company procedures and policies must be adhered to.
- Railway company rules governing rail travel must be observed at all times.
- Ensure that the position and function of all railgear controls are known before attempting operation.
- Ensure the railgear is locked in road or rail position before starting road or rail travel respectively.
- Ensure all body parts and loose clothing are clear of any moving parts of the equipment.
- If misalignment of the railgear equipment is indicated, promptly perform the alignment procedure.
- Before performing any work under the vehicle or railgear, ensure the engine is turned off and the parking brake is set.
- Never operate the vehicle if the Gross Vehicle Weight Rating (GVWR), Gross Axle Weight Rating Front or Rear (GAWR), or the wheel or tire load ratings are exceeded.
- Always disconnect the vehicle's battery when welding on the vehicle or railgear in order to protect the vehicle's electrical system.

OPERATION OF ROTATING REAR RAILGEAR

With the railgear kit installed on this vehicle, it may be operated as normal, however the vehicle has decreased ground clearance and angles of approach and departure due to the railgear. Caution must be used when operating the vehicle.

Never operate the vehicle if the Gross Vehicle Weight Rating (GVWR), Gross Axle Weight Rating Front or Rear (GAWR), or the wheel or tire load ratings are exceeded.

Refer to the Hydraulic Kit Operation, Service, and Parts manual for information on the location and operation of the railgear hydraulic system controls.

Placing the Vehicle on Rail - To Lower the Railgear:

1. Disengage the mechanical locking pins by pulling on the locking cable handle or lever. Do not force the locking cable/lever. If the lock pins cannot be disengaged, raise the railgear slightly.
2. Hold the locking cable handle/lever in the disengaged position.
3. Lower the railgear and release the locking cable handle/lever once the railgear has rotated past the road locked position.
4. As the railgear is being deployed, it will start taking some of the vehicle's load. (If this is not the case, **DO NOT use the railgear**. Inspect the railgear for lubrication and damage.)
5. Continue lowering the railgear until the hydraulic cylinders are fully extended. In this position, the railgear should be about 2-3° over center.

Removing the Vehicle from Rail - To Raise the Railgear:

1. Raise the railgear.
2. Continue raising the railgear until the lock pins click into the road locked position. The hydraulic cylinders should be completely retracted.
3. Ensure that the lock pins are engaged.

SERVICE OF ROTATING REAR RAILGEAR

The railgear kit must be serviced regularly to avoid damage to the equipment. Table 1 below provides the Recommended Service Schedule and the detailed service procedures follow.

Figure 1 provides the Non-Standard Fastener Torque Values. Table 2 provides Standard Fastener Torque Values for all other fasteners.

Grease fittings are provided at all railgear lubrication points as shown in Figure 2. The recommended lubricant for all lubrication points on this railgear is **MYSTIK JT-6 LOW TEMP** grease or equivalent. In cold weather areas/seasons, SHELL DARINA XL102 or equivalent may be used.

Table 1: Recommended Service Schedule

Description		Daily	Weekly	Monthly	3Months	6 Months	12 Months
1	Visually inspect the railgear prior to use for damaged or worn parts	✓					
2	Check for loose wheels and fasteners	✓					
3	Ensure the rail gear lock-up system is functioning properly in both the road and rail positions.	✓					
4	Check and adjust truck tire pressure as per requirements	✓					
5	Ensure the vehicle is in good operating condition based on the vehicle operating and maintenance instructions	✓					
6	Check and adjust rail wheel end play (0.005" max.)						✓
7	Inspect railgear wheel flanges for wear. Use the "RAFNA Wheel Flange Indicator" for measurement		✓				
8	Inspect all hydraulic fittings and hoses for leaks or wear	✓					
9	Inspect rail sweeps for proximity to rail head	✓					
10	Grease hydraulic cylinder pivot points			✓			
11	Grease inner tube lower pivot points			✓			
12	Grease inner tubes			✓			
13	Lubricate locking mechanism			✓	✓	✓	
14	Check level on hydraulic reservoir. Top off with appropriate filtered fluid	✓					
15	Inspect and grease railgear wheel bearings						✓
16	Check and correct rail wheel alignment, if gear is removed or damaged, or every 12 months						✓

Note:

For continuous service at ambient temperatures above 40°C (105°F), more frequent lubrication is required.

Table 2: Standard Fastener Torque Values

Fastener Size	Fastener Torque Value (ft-lbs) Dry
1" UNC Gr. 8 Fasteners	250
3/4" UNC Gr. 8 Fasteners	175
5/8" UNC Gr. 8 Fasteners	150
1/2" UNC Gr. 8 Fasteners	100
3/8" UNC Gr. 8 Fasteners	40
1/4" UNC Gr. 8 Fasteners	12

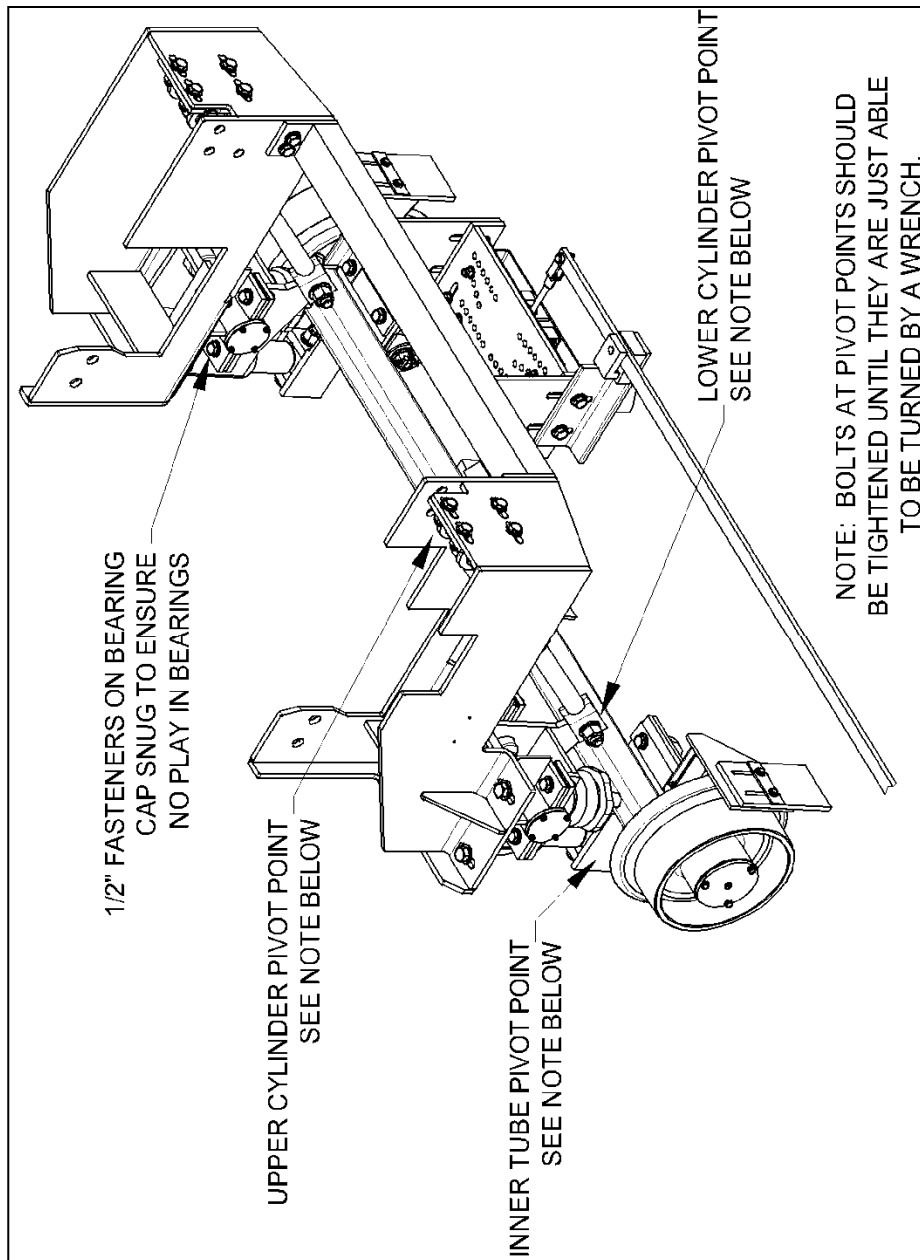

Figure 1: Non-Standard Fastener Torque Values

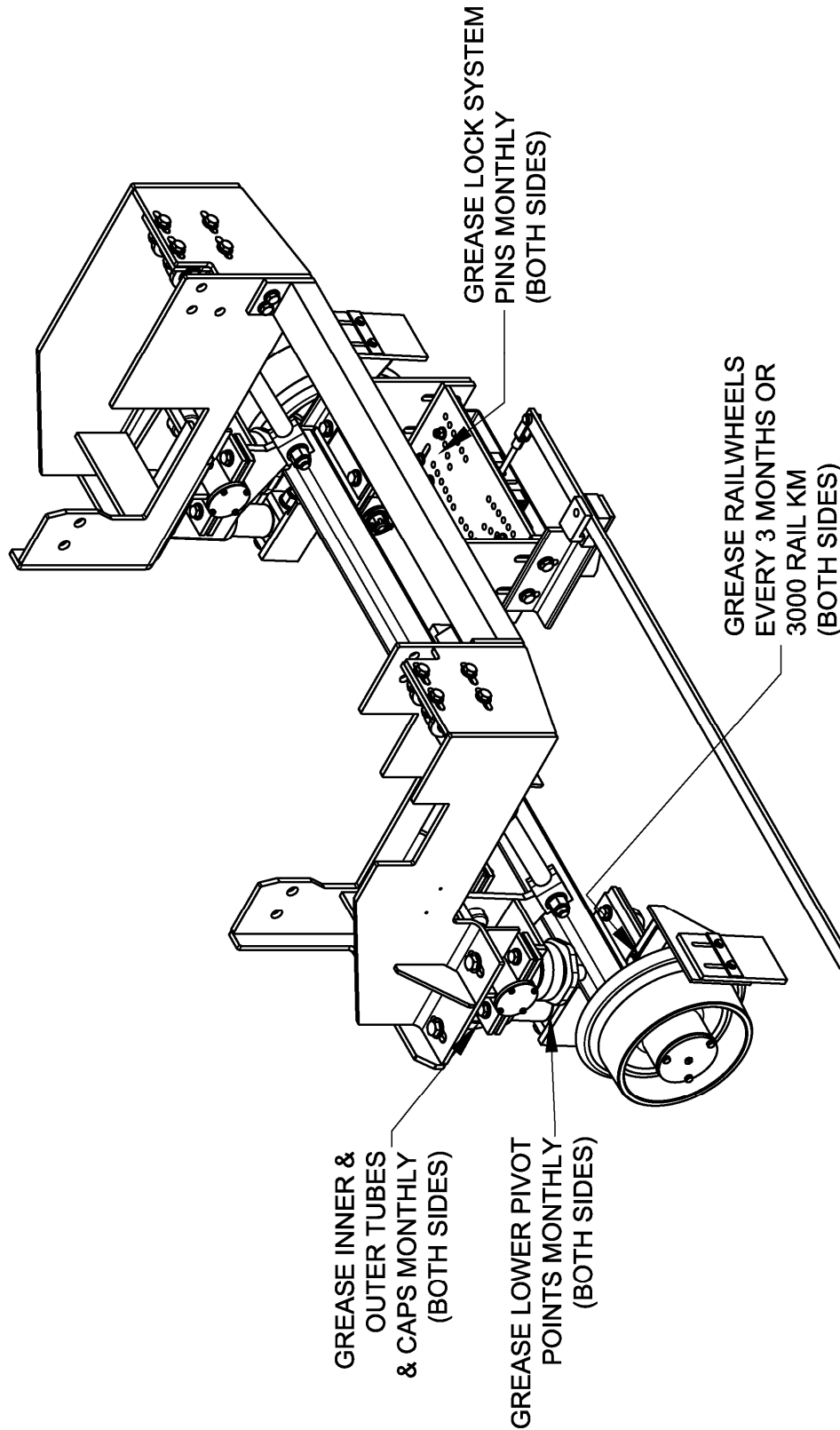

Figure 2: Railgear Lubrication Points

RAILGEAR OVER-CENTER ADJUSTMENT

The railgear is designed to rotate slightly past vertical into the rail position in order to provide a secondary safety feature in the event of a hydraulic and / or lock pin failure. This additional rotation past vertical is called the over-center angle and is set via the stroke of the hydraulic cylinder. The location of the railgear in the road position is also a function of the over-center adjustment, however, DO NOT use the over-center adjustment to adjust the road position of the railgear. This will have adverse effects on the over-center safety feature.

The over-center angle is defined as the angle between the vertical edge of the outer guide tubes and the vertical. It can be measured with the vehicle on a level section of rail with the railgear in the rail position using an angle meter. The over-center angle must be between 2° - 3° past vertical. If this is not the case, adjust as follows:

1. Locate K-R4628SHIM Kit provided with Railgear unit.
2. Unload the railgear hydraulic cylinder by raising the railgear out of the rail position.
3. Support the railgear axle and remove the bolts for the hydraulic cylinder support. (Item 3)
4. Determine what shim/shims would be needed to achieve the proper 2° -3° over center and install between the cylinder support and mounting bracket using newly supplied hardware in kit. (Items 2 & 3) (Refer to K-R4628SHIM drawing for shim to degree equivalent) (Discard old hardware, it will not be re-used)
5. Repeat process for remaining cylinder.
6. Both cylinders should have the same amount of shim to stroke evenly over center. This will help to eliminate any binding or twisting of the railgear when deployed to the rail position.
7. Test the railgear through its full range of motion for binding.
8. Re-measure the over-center angle. Repeat process if the angle is still not correct.
9. Following the over-center angle adjustment, the railgear may contact the vehicle if not enough clearance was left during installation. Check the railgear clearance to all vehicle components throughout the full range of railgear and railgear suspension movement. If there is interference with the vehicle bumper, it can be trimmed and reinforced as required.
10. With the railgear fully raised to the road position, ensure that the railgear lock has properly engaged.

PARTS LIST			
ITEM	PART NUMBER	DESCRIPTION	QTY
1	R-4628	HYDRAULIC CYLINDER ASSEMBLY	-
2	R-4804D	R-450 REAR DS MOUNTING BRACKET	-
3	R-4818	HYDRAULIC CYLINDER SUPPORT	-
4	R-4818A	CYLINDER SHIM, 1/8"	4
5	R-4818B	CYLINDER SHIM, 1/4"	2
6	R-4818C	CYLINDER SHIM, 3/8"	2
7	990800-275-22	1/2" X 2 3/4" LG. FULL THRD. UNC. GR.8	8
8	990316-050-22	NUT, 1/2" GR. 8 HEX NYLOCK Z/Y	8
9	990600-050-002	WASHER, 1/2" SAE THRU HD FLAT Z/Y	16

REFERENCE: R-990KIT-477 FOR HARDWARE

NOTES

- 1/8" SHIM EQUALS APPROXIMATELY 1° INCREASE.
- 1/4" SHIM EQUALS APPROXIMATELY 2° INCREASE.
- 3/8" SHIM EQUALS APPROXIMATELY 3° INCREASE.
- EQUAL SHIM MUST BE USED ON BOTH SIDES TO ENSURE PROPER FUNCTION OF RAILGEAR.
- IF MORE SHIM IS REQUIRED THAN WHAT IS PROVIDED, PLEASE CONTACT G&B SPECIALTIES FOR FURTHER ASSISTANCE.
- DISCARD OLD HARDWARE, IT WILL NOT BE RE-USED.
- REPLACE HARDWARE WITH KIT PROVIDED.
- ENSURE RAILGEAR ROTATES THROUGH FULL RANGE OF MOTION AND DOES NOT BIND AT ANY POINT ONCE SHIMS ARE INSTALLED.
- WHEN PROPERLY SHIMMED, RAILGEAR SHOULD BE 2°-3° OVER CENTER.
- PART OF MOUNTING BRACKET REMOVED FOR CLARITY.

DRIVER SIDE SHOWN, PASSENGER SIDE SAME

REV	DESCRIPTION OF CHANGES	DATE	BY	APPRVD	ECN#
A	REVISION A RELEASED	11/14/22	SMM	JMP	

REV	DESCRIPTION OF CHANGES	DATE	BY	APPRVD	ECN#
JMP	SMM				
JMP	JMP				
JMP	JMP				

REV	DESCRIPTION OF CHANGES	DATE	BY	APPRVD	ECN#
1	KR4628SHIM	11/14/22	K	R4628SHIM	A

G & B SPECIALTIES INC.
MANUFACTURER OF QUALITY RAILROAD PRODUCTS
BERWICK, PENNSYLVANIA (570) 752-5901, FAX (570) 752-6397
DESIGN - ENGINEERING - MANUFACTURING
R-450 REAR RAILGEAR CYLINDER SHIM KIT
PART NUMBER: 11/14/22

Cylinder Shim

RAIL WHEEL BEARING ADJUSTMENT

The rail wheel bearings require periodic adjustment in order to keep the end-play within specification. If the rail wheel bearings are not correctly adjusted, failure may occur that will not be covered under the railgear warranty. Check and adjust the bearing end-play with the railgear in the road position and with the rail wheels free to turn.

Use a magnetic base dial gauge to measure the end-play of each rail wheel bearing. The bearing end-play must be between 0.001" and 0.005". If this is not the case, adjust as follows:

1. Remove the rail wheel hubcap and gasket by removing the three 1/4" bolts and 1/4" lock washers.
2. Remove the spindle nut cotter pin.
3. Ensure that the wheel bearing cavity is full of grease.
4. While rotating the rail wheel forward, torque the spindle nut to 20 ft-lbs. Then loosen the spindle nut and re-torque it to 6 ft-lbs. Re-check and re-adjust the bearing end-play if required. If no torque wrench is available, tighten the spindle nut until the rail wheel is difficult to turn by hand. Then loosen the spindle nut and retighten it just until no looseness can be felt in the bearings. Re-adjust the bearing end-play with a torque wrench as soon as possible.
5. Install a new 3/16" x 2" long cotter pin through the spindle nut. Tighten the spindle nut slightly if needed to insert the cotter pin.
6. Re-install the hubcap and gasket using the 1/4" bolts and new 1/4" lock washers. Blue Loctite can be used on the bolts as an added safety measure. Tighten and torque the 1/4" fasteners to 12 ft-lbs dry. Do not over torque.

RAIL SWEEP ADJUSTMENT

The distance between the rail sweep rubber and the rail is adjustable and should be maintained at approximately 1/8". To adjust the rail sweep rubber, with the railgear in the rail position, loosen the two 1/4" fasteners which secure the rail sweep rubber to the rail sweep bracket. Slide the rail sweep rubber up or down for the correct clearance. Tighten and torque the 1/4" fasteners to 12 ft-lbs dry. Do not over torque.

RAIL WHEEL LOAD ADJUSTMENT

During rail travel, the railgear removes a predetermined portion of the vehicle's load from the vehicle's wheels and carries it on the rail wheels. A minimum amount of load must be maintained on the rail wheels in order to avoid derailment. Likewise, a minimum amount of load must be maintained on the vehicle wheels in order to provide traction for acceleration and braking.

The rail wheel load should be adjusted following the installation of the railgear once the vehicle has had all its permanent load (service body, crane, welders, etc.) installed. The rail wheel load requires periodic checks; however, it should only require re-adjustment if the railgear is moved, the vehicle equipment is changed, or the vehicle suspension settles or is changed. As non-permanent load is added to and/or removed from the vehicle, the rail wheel load will change also. This is acceptable as long as the weight ratings of the vehicle, axles, wheels, tires and railgear are not exceeded and as long as the minimum rail wheel load is maintained.

The rail wheel load must be a minimum of 800 lbs and is checked as described below using a hydraulic bottle jack equipped with a gauge. If the gauge on the hydraulic bottle jack reads in pounds per square inch (psi), use Table 5 along with the jack bore diameter to convert this reading to pounds (lbs). If the gauge reads in pounds, then no conversion is required.

Check each rail wheel load as follows:

1. Place the vehicle on a straight and level section of rail with the railgear lowered to the rail position. Ensure the railgear is taking load through the tread of the rail wheel and not on the flange of the rail wheel. The vehicle should only be carrying the permanently attached load (service body, crane, etc.) and any always carried non-attached load (welders, etc.) during this procedure. Do not include the operator or passengers. Ensure the vehicle tires have been inflated to the manufacturer's recommended air pressure and that they are not in contact with any obstructions except the rails.
2. Place the hydraulic bottle jack on a solid surface beneath the rail wheel spindle housing and jack the rail wheel off the rail.
3. Insert a piece of paper between the rail and the rail wheel. Lower the jack until the rail wheel squeezes the paper so that it cannot be pulled out.
4. Slowly jack up the rail wheel while pulling on the paper and observe the jack gauge. When the paper can be pulled out, stop jacking.
5. Record the load or pressure reading on the jack gauge.
6. If necessary, convert the pressure reading to a load reading using the supplied table.

Adjust each rail wheel load as follows:

There are two rubber springs on the railgear located between each railgear outer tube assembly and spring plate. Each spring is held in place by a nylock nut above it and a spring plate with a jam nut below it. The spring plate can be lowered and raised on the threaded rod to correspondingly decrease and increase the rail wheel load.

1. Raise the railgear until the rail wheels are off the rails.
2. Loosen the 1" nylock nut above each spring and the 1" jam nut under each spring plate.
3. To decrease the load on the rail wheels, lower the spring plates on the threaded rods. To increase the load on the rail wheels, raise the spring plates on the threaded rods. Each side should be adjusted the same amount.
4. Lower the railgear to the rail position and re-check the rail wheel loads. Re-adjust the rail wheel loads if necessary.
5. Raise the railgear until the rail wheels are off the rails. Tighten the 1" jam nut on the threaded rod so that they are tight against the spring plate.
6. Tighten the 1" nylock nuts above the springs so that the rubber springs are compressed to 3.75".
7. Following the rail wheel load adjustment, the railgear may contact the vehicle if not enough clearance was left during installation. Check the railgear clearance to all vehicle components throughout the full range of railgear and railgear suspension movement. If there is interference with the vehicle exhaust system, it can be bent to fit, ensuring any exhaust system modifications conform to applicable laws and regulations. If there is interference with any other vehicle components, please call G&B Specialties, Inc. for technical assistance.

Table 5: Rail Wheel Load vs Jack Pressure and Bore

Jack Pressure (PSI)	Jack Cylinder Bore Diameter (inches)								
	7/8	15/16	1	1 1/16	1 1/8	1 3/16	1 1/4	1 5/16	1 3/8
540	320	370	420	480	540	600	660	730	800
560	340	390	440	500	560	620	690	760	830
580	350	400	460	510	580	640	710	780	860
600	360	410	470	530	600	660	740	810	890
620	370	430	490	550	620	690	760	840	920
640	380	440	500	570	640	710	790	870	950
660	400	460	520	590	660	730	810	890	980
680	410	470	530	600	680	750	830	920	1010
700	420	480	550	620	700	780	860	950	1040
720	430	500	570	640	720	800	880	970	1070
740	440	510	580	660	740	820	910	1000	1100
760	460	520	600	670	760	840	930	1030	1130
780	470	540	610	690	780	860	960	1060	1160
800	480	550	630	710	800	890	980	1080	1190
820	490	570	640	730	820	910	1010	1110	1220
840	510	580	660	740	830	930	1030	1140	1250
860	520	590	680	760	850	950	1060	1160	1280
880	530	610	690	780	870	970	1080	1190	1310
900	540	620	710	800	890	1000	1100	1220	1340
920	550	640	720	820	910	1020	1130	1240	1370
940	570	650	740	830	930	1040	1150	1270	1400
960	580	660	750	850	950	1060	1180	1300	1430
980	590	680	770	870	970	1090	1200	1330	1460
1000	600	690	790	890	990	1110	1230	1350	1480
1020	610	700	800	900	1010	1130	1250	1380	1510
1040	630	720	820	920	1030	1150	1280	1410	1540
1060	640	730	830	940	1050	1170	1300	1430	1570
1080	650	750	850	960	1070	1200	1330	1460	1600
1100	660	760	860	980	1090	1220	1350	1490	1630
1120	670	770	880	990	1110	1240	1370	1520	1660
1140	690	790	900	1010	1130	1260	1400	1540	1690
1160	700	800	910	1030	1150	1280	1420	1570	1720
1180	710	810	930	1050	1170	1310	1450	1600	1750
1200	720	830	940	1060	1190	1330	1470	1620	1780
1220	730	840	960	1080	1210	1350	1500	1650	1810
1240	750	860	970	1100	1230	1370	1520	1680	1840
1260	760	870	990	1120	1250	1400	1550	1700	1870
1280	770	880	1010	1130	1270	1420	1570	1730	1900
1300	780	900	1020	1150	1290	1440	1600	1760	1930
1320	790	910	1040	1170	1310	1460	1620	1790	1960
1340	810	920	1050	1190	1330	1480	1640	1810	1990
1360	820	940	1070	1210	1350	1510	1670	1840	2020
1380	830	950	1080	1220	1370	1530	1690	1870	2050
1400	840	970	1100	1240	1390	1550	1720	1890	2080
1420	850	980	1120	1260	1410	1570	1740	1920	2110
1440	870	990	1130	1280	1430	1590	1770	1950	2140
1460	880	1010	1150	1290	1450	1620	1790	1980	2170
1480	890	1020	1160	1310	1470	1640	1820	2000	2200
1500	900	1040	1180	1330	1490	1660	1840	2030	2230
1520	910	1050	1190	1350	1510	1680	1870	2060	2260
1540	930	1060	1210	1370	1530	1710	1890	2080	2290
1560	940	1080	1230	1380	1550	1730	1910	2110	2320
1580	950	1090	1240	1400	1570	1750	1940	2140	2350
1600	960	1100	1260	1420	1590	1770	1960	2160	2380
1620	970	1120	1270	1440	1610	1790	1990	2190	2410
1640	990	1130	1290	1450	1630	1820	2010	2220	2440
1660	1000	1150	1300	1470	1650	1840	2040	2250	2460
1680	1010	1160	1320	1490	1670	1860	2060	2270	2490
1700	1020	1170	1340	1510	1690	1880	2090	2300	2520
1720	1030	1190	1350	1530	1710	1900	2110	2330	2550
1740	1050	1200	1370	1540	1730	1930	2140	2350	2580

Rail Wheel Load (lbs)

RAILGEAR ALIGNMENT

The railgear must be correctly aligned to perform properly, safely, and avoid excessive wear and derailment. The rail wheels can be independently aligned for toe-in/toe-out and the railgear can be adjusted side to side (laterally) on the vehicle. A parallel line system and the following procedure should be used to perform the railgear alignment.

The rail wheel loads should be checked and adjusted, the vehicle should have had a four-wheel alignment (with the complete railgear package installed on the vehicle and any suspension modifications done) and the tires should be properly inflated prior to performing the railgear alignment.

The railgear alignment is done with the vehicle on a straight and level section of rail with the railgear in the rail position and the vehicle wheels pointing straight ahead. The individual rail wheel alignment should be done first, followed by the lateral alignment of the railgear.

Each rail wheel is aligned by loosening the four 1/2" fasteners that secure it to the railgear axle. The rail wheel is then turned into alignment. The four 1/2" fasteners should then be tightened and torqued to 100 ft-lbs dry. Do not over torque.

The railgear is aligned laterally by loosening the eight 5/8" fasteners that secure it to the railgear mounting boxes. The railgear is then moved sideways into alignment. It may be necessary to raise the railgear off the rails to move the railgear side to side. Do not use any force against the railgear guide tubes as this may damage them and restrict suspension movement. The eight 5/8" fasteners should then be tightened and torqued to 150 ft-lbs dry. Do not over torque.

Refer to Figure 5 for alignment measurement and specifications. Use an 18" magnetic straight edge on the back of each rail wheel to measure from.

Following the railgear alignment, the railgear may contact the vehicle if not enough clearance was left during installation. Check the railgear clearance to all vehicle components throughout the full range of railgear and railgear suspension movement. If there is interference with the vehicle bumper, it can be trimmed and reinforced as required. If there is interference with the vehicle exhaust system, it can be bent to fit, ensuring any exhaust system modifications conform to applicable laws and regulations. If there is interference with any other vehicle components, please call G&B Specialties, Inc. for technical assistance.

RAFNA RAILGEAR ALIGNMENT RACK DATA

GAS OR DIESEL _____ VIN# _____

VEHICLE MAKE: _____ VEHICLE MODEL: _____ VEHICLE YEAR: _____
 DOOR STICKER GVWR: _____ DOOR STICKER GAWR FRT: _____ DOOR STICKER GAWR RR _____
 RAILGEAR S/N: FRT _____ RR _____ VEHICLE UNIT #,S/N: _____
 RAILGEAR TYPE: _____ INSTALLER: _____ DATE: _____

SET UP PARALLEL STRING LINES
 A & B MUST BE EQUAL WITHIN 1/32"
 C & D MUST BE EQUAL WITHIN 1/32"

ADJUST STRING LINES AROUND VEHICLE
 E, F, G, & H MUST BE EQUAL WITHIN 1/16"
 I, J, K, & L MUST BE EQUAL WITHIN 1/16"
 (E, F, G, & H MAY NOT EQUAL I, J, K, & L)

ADJUST RAIL WHEEL ALIGNMENT
 M & O MUST BE EQUAL WITHIN 1/16"
 N & P MUST BE EQUAL WITHIN 1/16"
 Q & S MUST BE EQUAL WITHIN 1/16"
 R & T MUST BE EQUAL WITHIN 1/16"

ADJUST RAILGEAR LATERAL ALIGNMENT
 M & O MUST EQUAL N & P WITHIN 1/8"
 Q & S MUST EQUAL R & T WITHIN 1/8"

ENSURE THAT U & V ARE BETWEEN
 53- 7/16" AND 53- 9/16"

OVER-CENTER ANGLE (DEGREE)
 FRONT _____
 REAR _____

RAIL WHEEL LOADS (LBS)
 LEFT FRONT _____ RIGHT FRONT _____
 LEFT REAR _____ RIGHT REAR _____

RAIL WHEEL FLANGE TO GROUND CLEARANCE
 LEFT FRONT _____ RIGHT FRONT _____
 LEFT REAR _____ RIGHT REAR _____

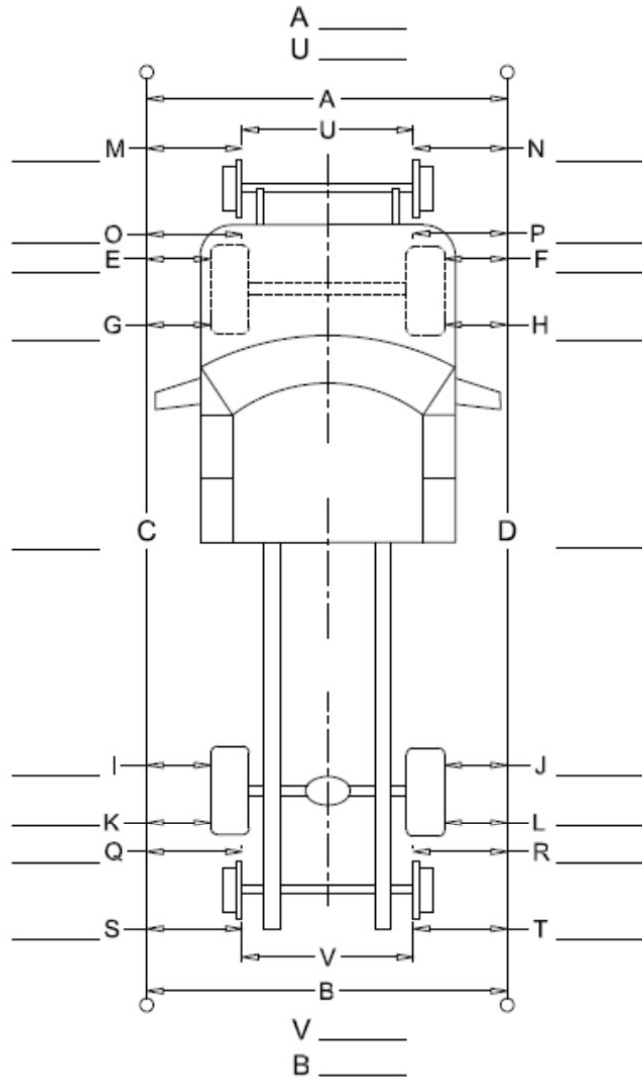

MOUNTING HEIGHT FRONT: _____ MOUNTING HEIGHT REAR: _____
 STOCK TURNING DIAMETER: _____ MODIFIED TURNING DIAMETER: _____
 OEM: VEHICLE WEIGHT: _____ FRONT GAWR: _____ REAR GAWR: _____
 MODIFIED: VEHICLE WEIGHT: _____ FRONT GAWR: _____ REAR GAWR: _____

FAX COMPLETED FORM TO JAKE SANUTE AT FAX # 570-802-0491

MAY 31, 2018 REV "D"

Figure 5: Railgear Alignment

RAFNA RAILGEAR PORTABLE ALIGNMENT DATA

GAS OR DIESEL _____ VIN# _____

VEHICLE MAKE: _____ VEHICLE MODEL: _____ VEHICLE YEAR: _____

DOOR STICKER GVWR: _____ DOOR STICKER GAWR FRT: _____ DOOR STICKER GAWR RR _____

RAILGEAR S/N: FRT _____ RR _____ VEHICLE UNIT #,S/N: _____

RAILGEAR TYPE: _____ INSTALLER: _____ DATE: _____

ADJUST RAILGEAR LATERAL ALIGNMENT
A MUST EQUAL B WITHIN 1/8"
C MUST EQUAL D WITHIN 1/8"

ENSURE THAT U & V ARE BETWEEN
53- 7/16" AND 53-9/16"

OVER-CENTER ANGLE (DEGREE)
FRONT _____
REAR _____

RAIL WHEEL LOADS (LBS)
LEFT FRONT _____ RIGHT FRONT _____
LEFT REAR _____ RIGHT REAR _____

RAIL WHEEL FLANGE TO GROUND CLEAR-
ANCE
LEFT FRONT _____ RIGHT FRONT _____
LEFT REAR _____ RIGHT REAR _____

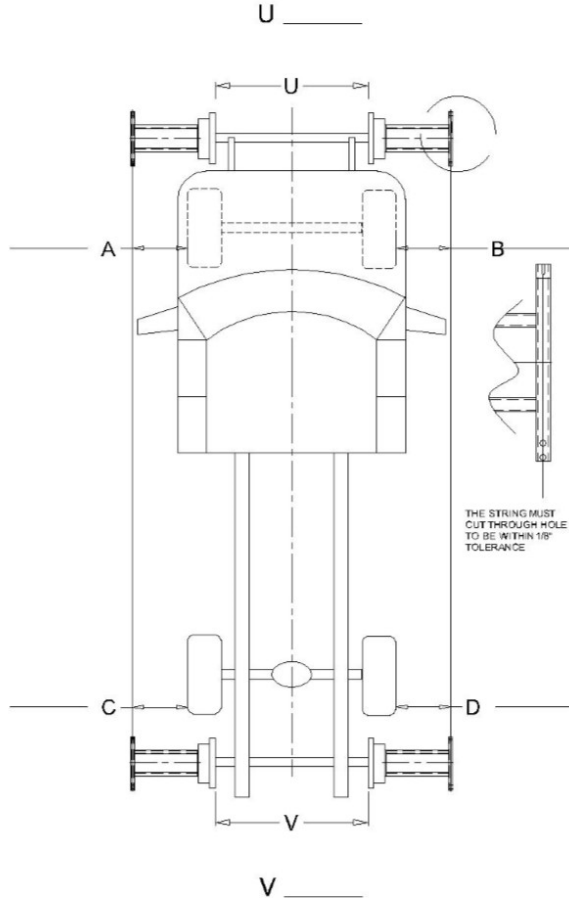

MOUNTING HEIGHT FRONT: _____ MOUNTING HEIGHT REAR: _____

STOCK TURNING DIAMETER: _____ MODIFIED TURNING DIAMETER: _____

OEM: VEHICLE WEIGHT: _____ FRONT GAWR: _____ REAR GAWR: _____

MODIFIED: VEHICLE WEIGHT: _____ FRONT GAWR: _____ REAR GAWR: _____

FAX COMPLETED FORM TO JAKE SANUTE AT FAX # 570-802-0491

MAY 31, 2018 REV B

Figure 6: Railgear Alignment Portable

RAILGEAR LOCK SYSTEM ADJUSTMENT PROCEDURE

The rear lock-up adjustment procedure is the same for all rear lock-up types.

The rear railgear lock system provides a mechanical locking mechanism to hold the railgear axle in the road position. For the system to function properly, the contact surface of the angle plate on the axle and the top surface of the locking pins must have a contact length of approximately 3/4" to 7/8" as shown by **Figure 7**. If these criteria are not met, the following procedure can be followed:

1. Raise the railgear to the road position. Support the railgear axle and the lock-up system.
2. Remove lock-up cover (if equipped).
3. Loosen the four 1/2" fasteners that secure the lock-up support to the lock-up frame.
4. Ensure the lock-up support is adjusted all the way down to the bottom of the adjustment slots. **Torque the four 1/2" fasteners to 100 ft-lbs dry. Do not over torque.**
5. Remove the four inside 3/8" fasteners that secure the lock-up plate to the lock-up support.
6. Lower the rear railgear until the bottom surface angle plate and the top surface of the lock pins are in contact with each other. **The angle plate and lock pins should be parallel to each other upon contact.**
7. If the angle plate and lock pins are not parallel to each other, the lock up support can be rotated and/or raised/lowered in its mounting slots to adjust the contact angle.
8. Loosen the two outside 3/8" fasteners that secure the lock-up plate to the lock-up support.
9. Adjust the lock-up plate in or out accordingly so that the contact surface of the angle plate and the top surface of the lock pins have a contact length of approximately 3/4" to 7/8".
10. The holes in the lock-up plate and the lock-up support allow for horizontal adjustment in 1/8" increments. Align the closest set of holes that will allow a contact length of approximately 3/4" to 7/8".
11. Re-install the four inside 3/8" fasteners that secure the lock-up plate to the lock-up support, that were removed in step #5 above. **Tighten but do not torque at this time.**
12. Retract the lock pins and lower the railgear. Raise the railgear and ensure that the lock system has been properly adjusted and functioning properly and that there are no interferences between lock-up and railgear axle.
13. With the railgear fully retracted to the road position and the lock-up adjusted as outlined in the previous steps, there should be approximately 3/4" clearance between the angle plate and lock pins as shown in **Figure 9**.
14. Repeat the above steps as necessary.
15. Tighten two outside 3/8" fasteners that secure the lock-up plate to the lock-up support.

16. Torque the 3/8" fasteners to 40 ft-lbs dry. Do not over torque.

Note

The rear railgear unit should be shipped with the lock-up assembly installed upside down (cover towards the ground). The rear lock-up can be removed and re-installed right side up (cover towards the truck). This is to accommodate and possible clearance, installation or adjustment issues that may come up. The installation/adjustment procedure is the same for either orientation.

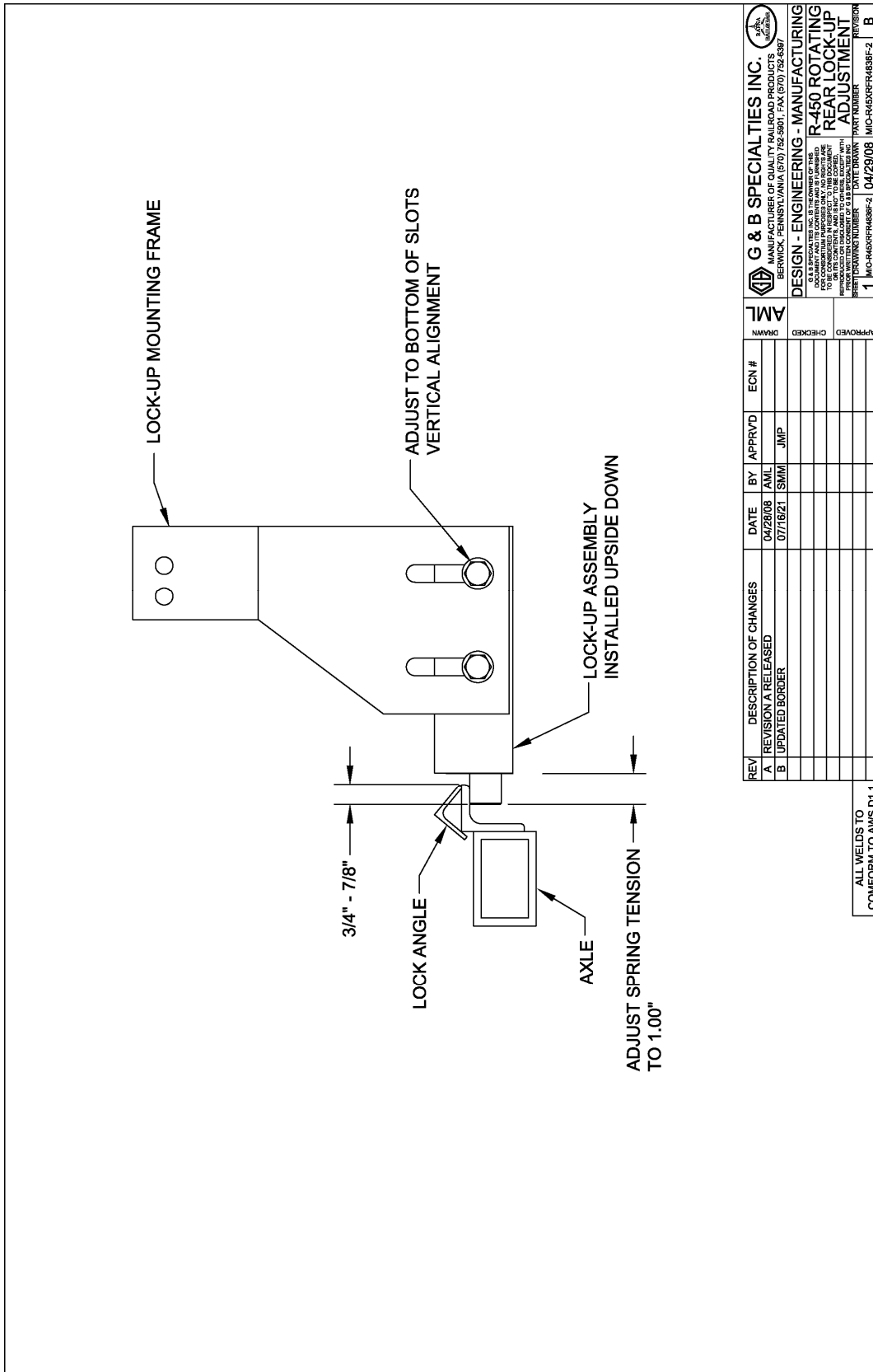

Figure 7

REV	DESCRIPTION OF CHANGES	DATE	BY	APPRVD	ECN #
A	REVISION A RELEASED	04/28/08	AML		
B	UPDATED BORDER	07/16/21	SMM	JMP	

ALL WELDS TO CONFORM TO AWS D1.1	
G & B SPECIALTIES INC. MANUFACTURERS OF QUALITY RAILROAD PRODUCTS BERWICK, PENNSYLVANIA (570) 752-5901, FAX (570) 752-6397	DESIGN - ENGINEERING - MANUFACTURING G & B SPECIALTIES INC. IS THE OWNER OF THIS DOCUMENT AND TO WHOMsoever IN THE EVENT OF DISCREPANCY BETWEEN THIS DRAWING AND THE DOCUMENT TO BE USED FOR CONSTRUCTION, THE DRAWING SHALL TAKE PRECEDENCE. THE USER SHALL BE RESPONSIBLE FOR VERIFYING THE ACCURACY OF THIS INFORMATION. SHEET DRAWING NUMBER: 1 DATE DRAWN: 04/28/08 PART NUMBER: MIO-R450FORD17-R450RF-2 REVISION: B

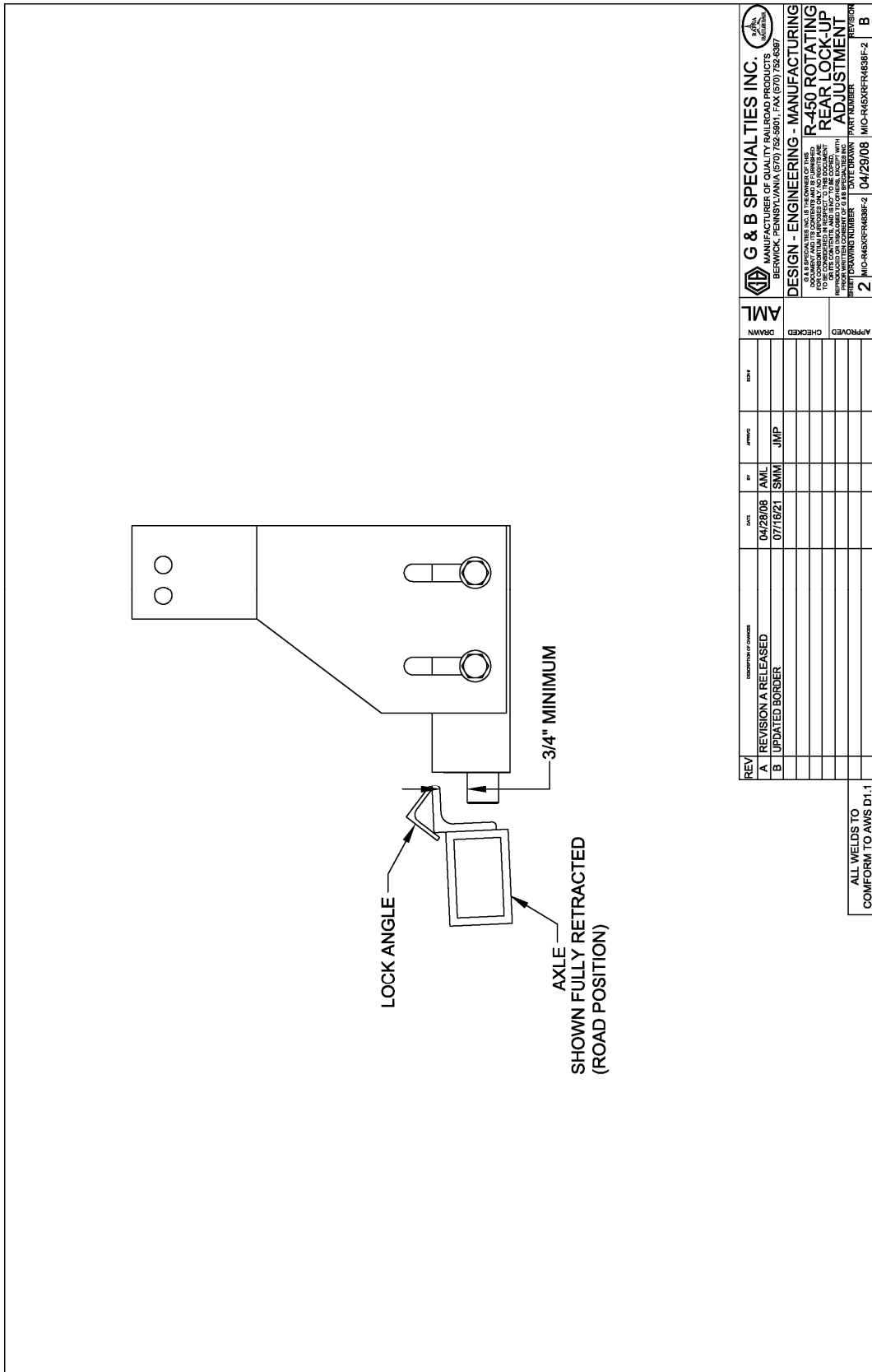

Figure 9

RAILGEAR LOCK SYSTEM SERVICE

The rear lock-up system needs to be routinely serviced and inspected to function properly.

Below is recommended service schedule that should be followed to help ensure the proper operation of the rear lock-up system.

Recommended Service Schedule - R-450 Rotating Rear Railgear

DESCRIPTION	DAILY	WEEKLY	MONTHLY	3 MONTHS
1. Visually inspect the rear lock-up system, prior to use, for damaged or worn parts.	✓			
2. Visually inspect the lock-up system for excessive accumulation of dirt, debris and any foreign matter; clean if necessary.		✓		
3. Check for loose or damaged fasteners.			✓	
4. Ensure the rail gear lock-up system is functioning properly in both the road and rail positions.	✓			
5. Pressure wash rear lock-up/railgear to remove any accumulated dirt.			✓*	✓
6. Lubricate rear lock-up.			✓*	✓

* PERFORM MONTHLY IF OPERATING IN EXCESSIVELY HAZARDOUS/DIRTY ENVIRONMENT*

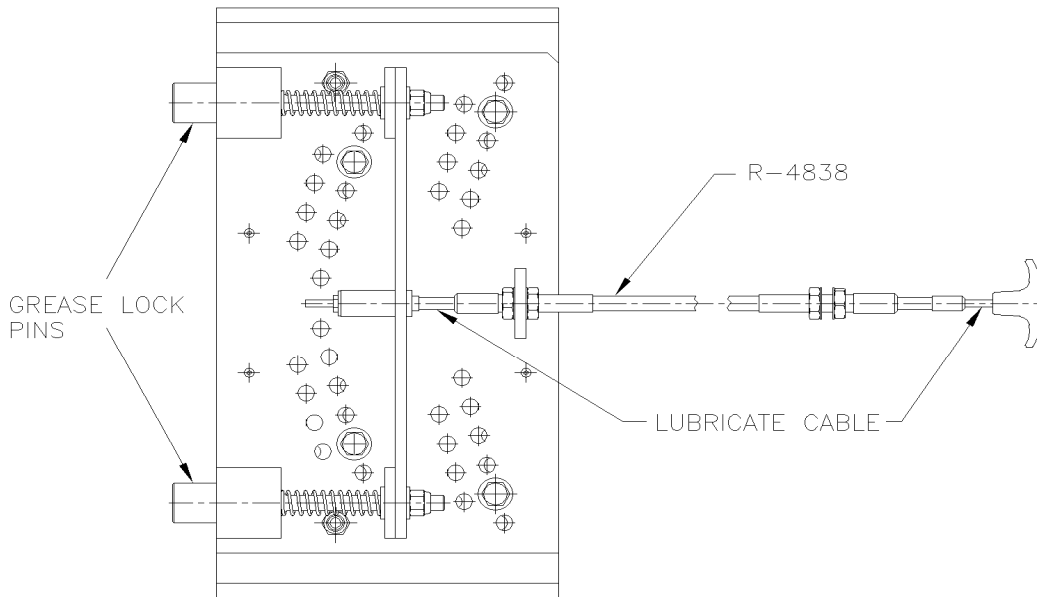

REAR LOCK-UP ASSEMBLY
CABLE ACTUATED

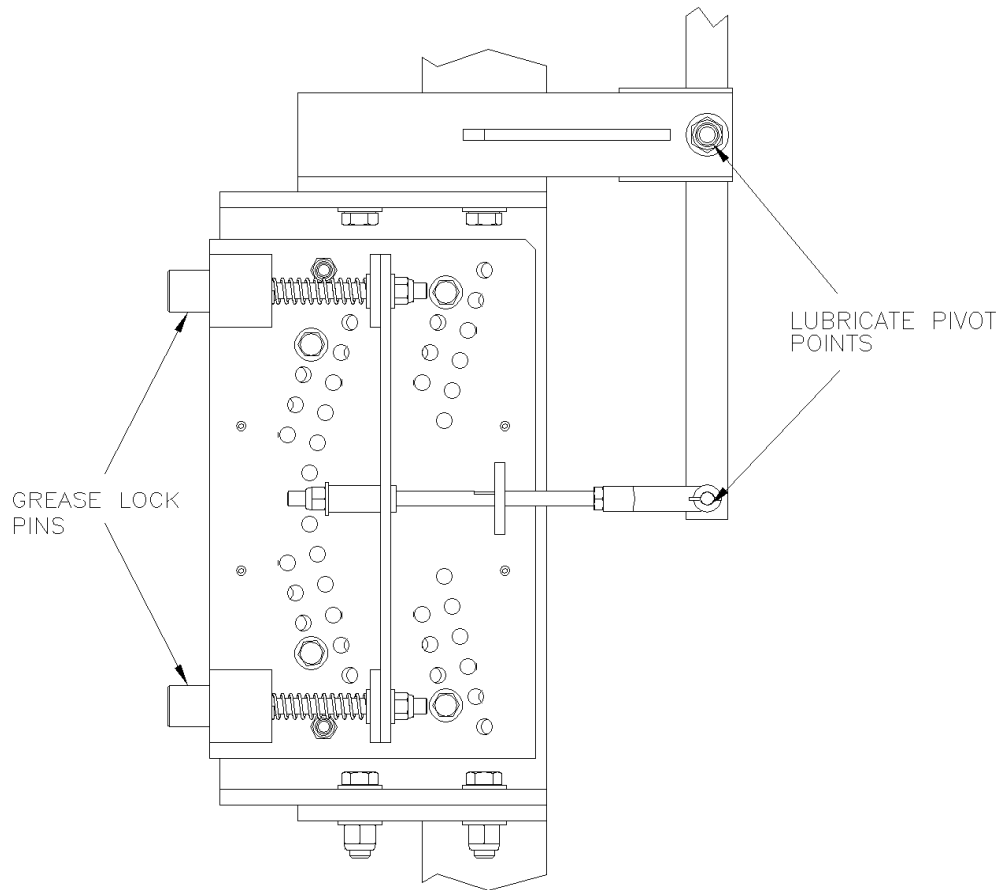

REAR LOCK-UP ASSEMBLY
LEVER ACTUATED

WHEEL WEAR STANDARDS AND RECOMMENDATIONS

At the present time, G&B produces 8", 10", 12", 14", and 16" steel wheels. Each size has a different flange and tread thickness, which dictates the allowable wear. Although the following numbers are recommended limits, risk of failure is increased when not followed. Rail gauge can be supplied by G&B Specialties for 8", 10", 12", 14", and 16" rail wheels. They are used as go/no go gauges. When placed on rail wheels they will indicate how much wear is still permissible or if the rail wheels need to be replaced.

The gauge for the R-450 model railgear can be ordered using the following part number; S-001200

- Rail wheel failure can result in equipment damage or failure, personal injury, or death.

Flange Wear Limits:

The maximum flange wear is indicated on the rail wheel gauge. When the gauge is placed on the rail wheel, if a gap is seen between the gauge and the maximum flange wear line, the rail wheel needs to be replaced.

Tread Wear Limits:

For tread wear, use the following chart in conjunction with the appropriate rail wheel gauge.

NOMINAL RAIL WHEEL DIAMETER (INCHES)	MIN. ALLOWABLE WHEEL DIAMETER (INCHES)
10	9 3/4

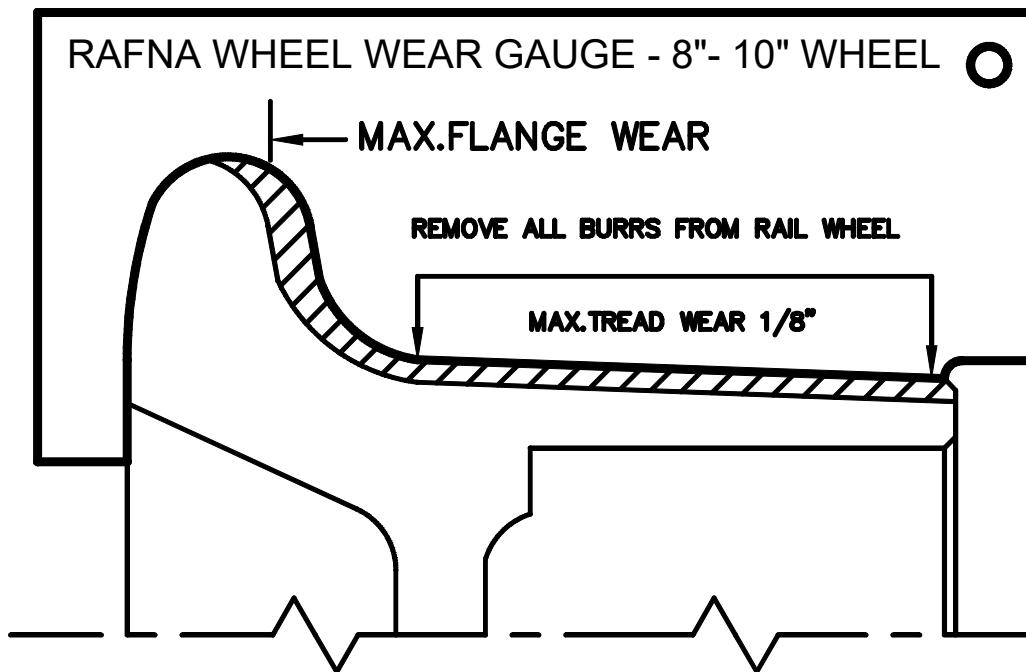

PARTS OF R-450 ROTATING REAR RAILGEAR

- NOTES:
1. ASSEMBLE AS SHOWN
 2. LOCK-UP IS TO BE INSTALLED UPSIDE DOWN AND ADJUSTED TO THE BOTTOM OF THE SLOTS.
 3. LOCK-UP MOUNTING HARDWARE IS INCLUDED WITH LOCK-UP ASSEMBLY.

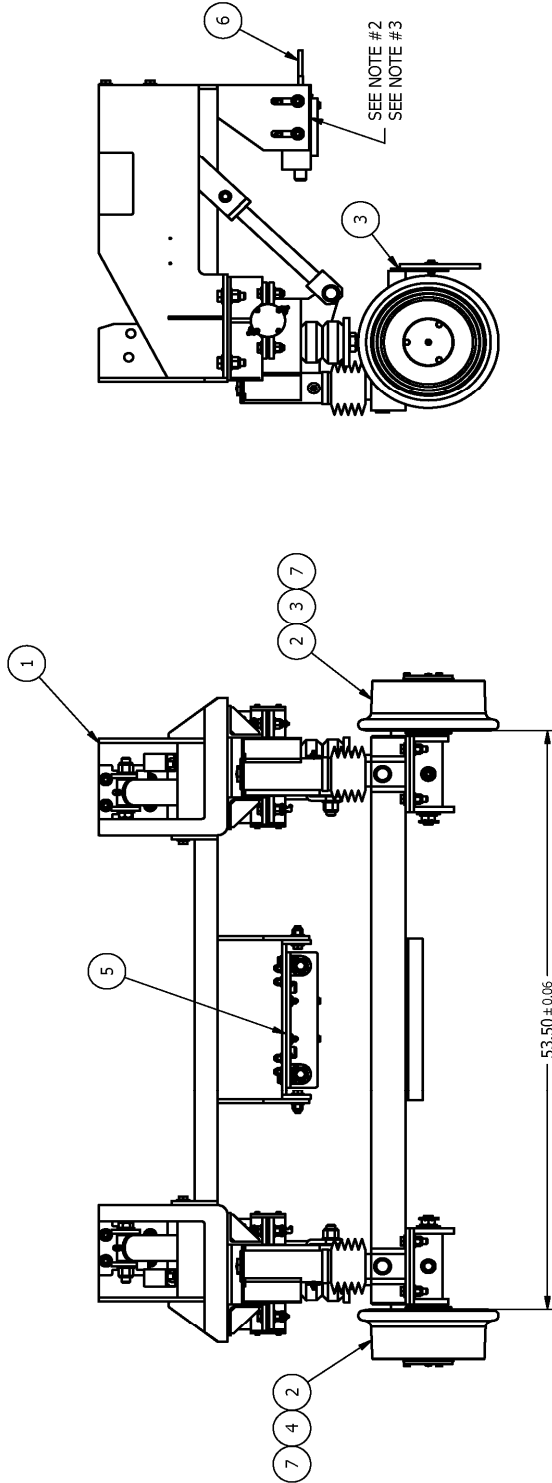

BILL OF MATERIAL PARTS LIST

ITEM	QTY	PART NUMBER	DESCRIPTION
1	1	R-4836G	R-450 ROTARY REAR, GENERIC
2	2	R-001	10" STEEL WHEEL ASSEMBLY
3	1	R-4646L	RAIL SWEEP ASSY., PASSENGER
4	1	R-4646R	RAIL SWEEP ASSY., DRIVER
5	1	R-4837E	AXLE LOCKUP ASSEMBLY, CABLE
6	1	R-4838	PUSH/PULL LOCKING CABLE
7	2	R-390KIT-204	KIT, WHEEL MOUNTING HARDWARE

REV	DESCRIPTION OF CHANGES	DATE	BY	APPRVD	ECN #	APPROVED	CHECKED	DRAWN
A	REVISION A RELEASED	04/26/08	AMIL					
B	REVISED BILL OF MATERIAL	04/03/18	JEV					

DESIGN - ENGINEERING - MANUFACTURING	DATE DRAWN	REV NUMBER	REV WORK
R-450 ROTARY REAR CABLE LOCK-UP	04/26/08	R-4836CBL	B

G & B SPECIALTIES INC.
MANUFACTURER OF QUALITY RAILROAD PRODUCTS
BERWICK, PENNSYLVANIA (570) 752-5901, FAX (570) 752-6397

AS A SPECIALTY ITEM, IS THE OWNER OF THIS EQUIPMENT RESPONSIBLE FOR THE PROPER USE OF THIS EQUIPMENT. THE USER SHALL BE RESPONSIBLE FOR THE PROPER MAINTENANCE AND REPAIR OF THIS EQUIPMENT. THE USER SHALL BE RESPONSIBLE FOR THE PROPER USE OF THIS EQUIPMENT. THE USER SHALL BE RESPONSIBLE FOR THE PROPER MAINTENANCE AND REPAIR OF THIS EQUIPMENT.

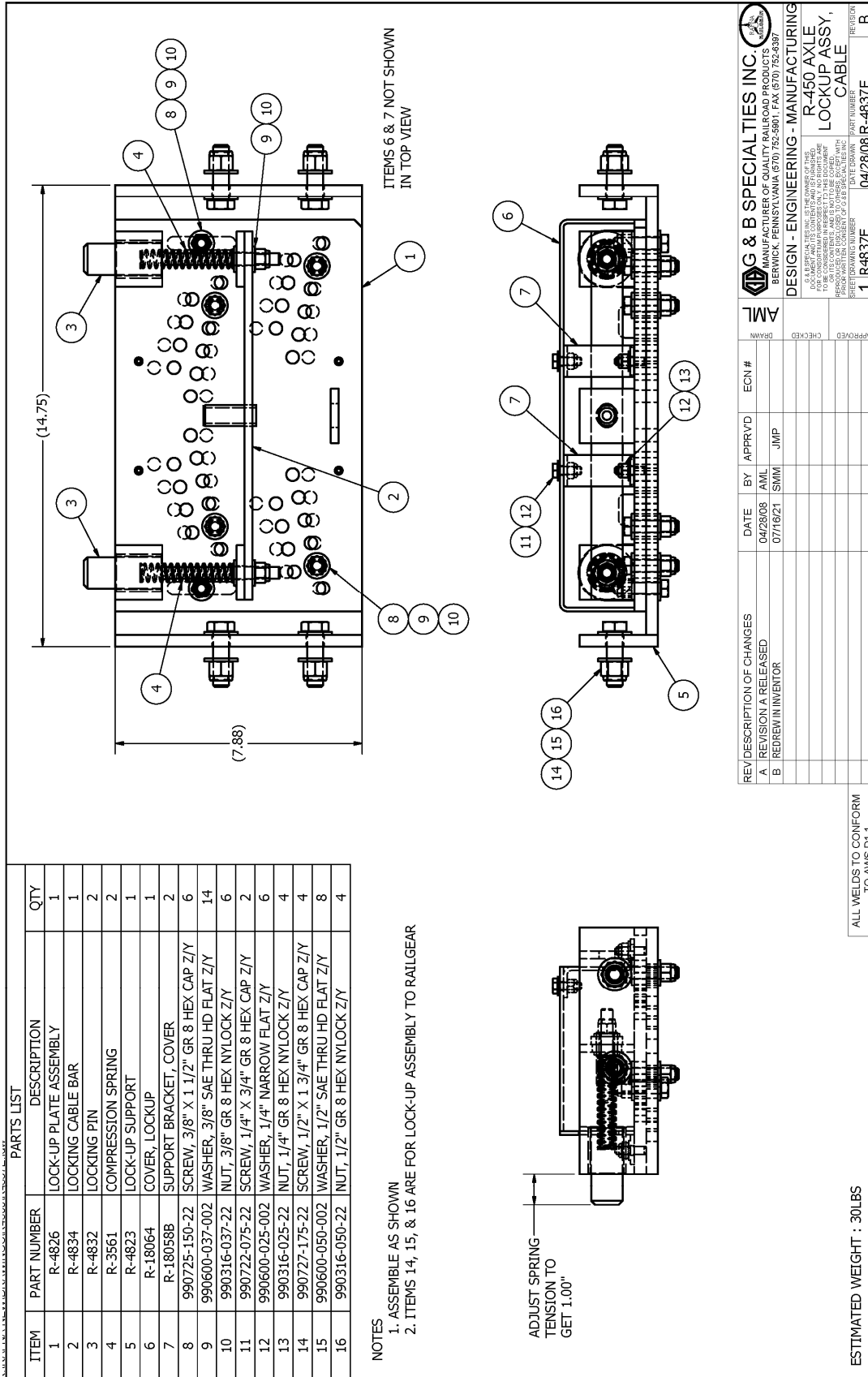

PARTS LIST			
ITEM	PART NUMBER	DESCRIPTION	QTY
1	R-4826	LOCK-UP PLATE ASSEMBLY	1
2	R-4834	LOCKING CABLE BAR	1
3	R-4832	LOCKING PIN	2
4	R-3561	COMPRESSION SPRING	2
5	R-4823	LOCK-UP SUPPORT COVER, LOCKUP	1
6	R-18064	SUPPORT BRACKET, COVER	2
8	990725-150-22	SCREW, 3/8" X 1 1/2" GR 8 HEX CAP Z/Y	6
9	990600-037-002	WASHER, 3/8" SAE THRU HD FLAT Z/Y	14
10	990316-037-22	NUT, 3/8" GR 8 HEX NYLOCK Z/Y	6
11	990722-075-22	SCREW, 1/4" X 3/4" GR 8 HEX CAP Z/Y	2
12	990600-025-002	WASHER, 1/4" NARROW FLAT Z/Y	6
13	990316-025-22	NUT, 1/4" GR 8 HEX NYLOCK Z/Y	4
14	990727-175-22	SCREW, 1/2" X 1 3/4" GR 8 HEX CAP Z/Y	4
15	990600-050-002	WASHER, 1/2" SAE THRU HD FLAT Z/Y	8
16	990316-050-22	NUT, 1/2" GR 8 HEX NYLOCK Z/Y	4

NOTES
1. ASSEMBLE AS SHOWN
2. ITEMS 14, 15, & 16 ARE FOR LOCK-UP ASSEMBLY TO RAILGEAR

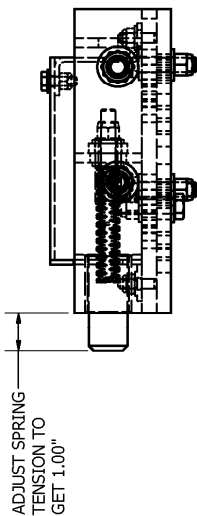

ESTIMATED WEIGHT : 30.LBS

ALL WELDS TO CONFORM TO AWS D1.1

REV	DESCRIPTION OF CHANGES	DATE	BY	APPRVD	ECN #	APPROVED	CHECKED	DRAWN
A	REVISION A RELEASED	04/28/08	AML	JMP				
B	REDREW IN INVENTOR	07/18/21	SMM					

G & B SPECIALTIES INC.
 MANUFACTURING
 BERWICK, PENNSYLVANIA (570) 752-5901 FAX (570) 752-6397
 DESIGN - ENGINEERING - MANUFACTURING
 R-450 AXLE LOCKUP ASSY, CABLE
 SHEET DRAWING NUMBER: 1 R4837E DATE DRAWN: 04/28/08 PART NUMBER: R4837E REVISION: B

BILL OF MATERIAL / PARTS LIST

ITEM	PART NUMBER	DESCRIPTION	QTY
1	R-4836G	R-450 ROTARY REAR, GENERIC	1
2	R-001	10" STEEL WHEEL ASSEMBLY	2
3	R-464L	RAIL SWEEP ASSY., PASSENGER	1
4	R-464R	RAIL SWEEP ASSY., DRIVER	1
5	R-4837B	AXLE LOCKUP ASSEMBLY, LEVER	1
6	R18109	ROD SUPPORT	REF
7	R-990KIT-204	KIT, WHEEL MOUNTING HARDWARE	2

HARDWARE REF: R-990KIT-204 (WHEEL MTG X2)

NOTES:

1. ASSEMBLE AS SHOWN
2. LOCK-UP IS TO BE INSTALLED UPSIDE DOWN AND ADJUSTED TO THE BOTTOM OF THE SLOTS.
3. LOCK-UP MOUNTING HARDWARE IS INCLUDED WITH LOCK-UP ASSEMBLY.
4. ITEM #6 IS PART OF KIT (K-R450XXR-4836) AND IS TO BE USED TO ASSEMBLE REAR LOCK-UP. ALL OTHER KIT PARTS ARE NOT TO BE ASSEMBLED AND SHIPPED SEPARATELY.

SEE NOTE #2
SEE NOTE #3
SEE NOTE #4

REV/DESCRIPTION OF CHANGES	DATE	BY	APPRVD	ECN #	APPROVED	CHECKED	DESIGNED
A REVISION A RELEASED	04/28/08	AML					
B REVISED BILL OF MATERIAL	04/03/18	JEV					

G & B SPECIALTIES INC.
MANUFACTURER OF QUALITY RAILROAD PRODUCTS
BERWICK, PENNSYLVANIA (670) 752-5901 FAX (670) 752-6397

DESIGN - ENGINEERING - MANUFACTURING

R-450 ROTARY REAR LEVER LOCK-UP

DATE DRAWN: 04/28/08
PART NUMBER: R-4836LVR
REV: B

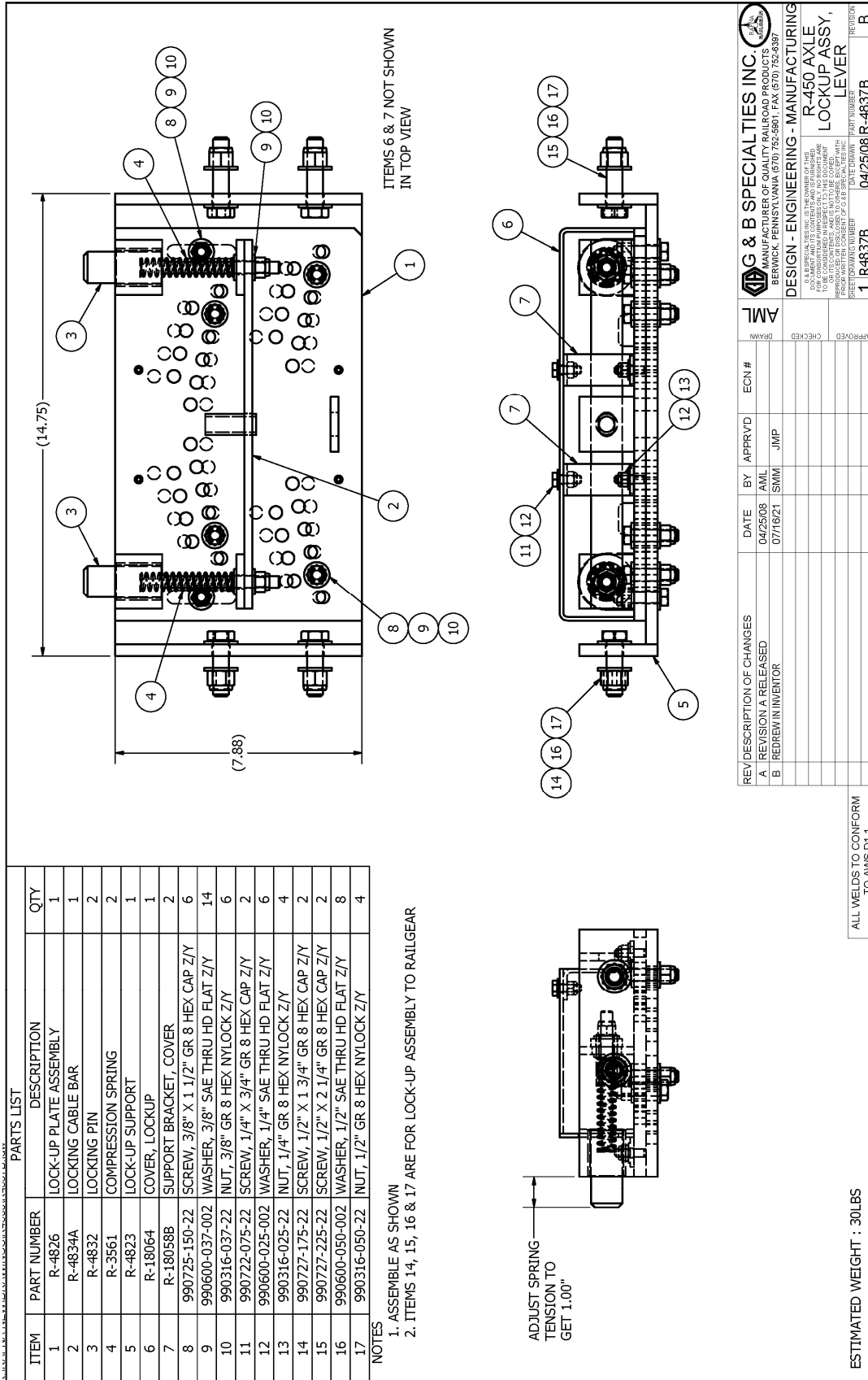

G & B SPECIALTIES INC. MANUFACTURER OF RAILROAD PRODUCTS BERWICK, PENNSYLVANIA (570) 752-5901 FAX (570) 752-6397		DESIGN - ENGINEERING - MANUFACTURING R-450 AXLE LOCKUP ASSY, LEVER	
AML APPROVED DRAWN	ECN #	DATE 04/25/08 07/18/21	BY JMP SMM
REV DESCRIPTION OF CHANGES A REVISION A RELEASED B REDREW IN INVENTOR	APPROVED CHECKED	DATE 04/25/08 07/18/21	BY JMP SMM
SHEET DRAWING NUMBER: 1 R4837B		DATE DRAWN: 04/25/08	
PART NUMBER: R-4837B		REVISION: B	

ITEM	PART NO.	PART DESCRIPTION	QTY
1	R-4836G	ROTATING REAR RAILGEAR	1
2	R-001	10" WHEEL ASSEMBLY (RIGHT SIDE NOT SHOWN)	2
3	R-4648R	RAIL SWEEP - DRIVER (NOT SHOWN)	2
4	R-4648L	RAIL SWEEP - PASSENGER SIDE	1
5	S-001051	RAILGEAR ORIENTATION DECAL (NOT SHOWN)	1
6	---	1 7/8" UNC GR. 8 BOLT X 2.25" LONG	8
7	---	GR. 8 WASHER	8
8	---	1 7/8" GR. 8 NYLOCK NUT	8
9	---	5/8" UNC GR. 8 BOLT X 2" LONG	8
10	---	GR. 8 WASHER	12
11	---	3/4" UNC GR. 8 NYLOCK NUT	6
12	---	5/8" UNC GR. 8 BOLT X 2.25" LONG	8
13	---	GR. 8 WASHER	8
14	---	3/4" UNC GR. 8 NYLOCK NUT	N/A
15	R-4837A	VEHICLE FRAME	N/A
	R-4837B	LOCK-UP ASSEMBLY, HYDRAULIC	
	R-4837C	LOCK-UP ASSEMBLY, LEVER	
	R-4837E	LOCK-UP ASSEMBLY, CABLE	
16			1

NOTE:
1. UNIT SHOWN WITHOUT LOCK-UP

REAR OF VEHICLE

REV	DESCRIPTION OF CHANGES	DATE	BY	APPRVD	EON #	APPROVED
A	REVISION A RELEASED	05/07/08	AMIL			
B	REVISED BILL OF MATERIAL	04/03/18	JEV			

AMIL DRAWN		APPROVED	DATE DRAWN	PART NUMBER	REVISION
			05/07/08	R-4836G-1	B

G & B SPECIALTIES INC. MANUFACTURER OF QUALITY RAILROAD PRODUCTS
BERWICK, PENNSYLVANIA (570) 752-5901, FAX (570) 752-5397
DESIGN - ENGINEERING - MANUFACTURING
O & B SPECIALTIES INC. IS THE OWNER OF THE INTELLECTUAL PROPERTY RIGHTS IN ALL PATENTS, TRADE SECRETS, AND OTHER INFORMATION CONTAINED HEREIN. NO PART OF THIS DOCUMENT IS TO BE REPRODUCED, COPIED, OR TRANSMITTED IN ANY FORM OR BY ANY MEANS, ELECTRONIC OR MECHANICAL, INCLUDING PHOTOCOPYING, RECORDING, OR BY ANY INFORMATION STORAGE AND RETRIEVAL SYSTEM, WITHOUT THE WRITTEN CONSENT OF G & B SPECIALTIES INC.

ITEM	PART NUMBER	DESCRIPTION	QTY
1	R-4813A	REAR AXLE ASSEMBLY	1
2	R-4812A	INNER GUIDE, REAR	2
3	R-476A	SPRING, REAR	2
4	R-462B	HYDRAULIC CYLINDER ASSEMBLY, R-450	2
5	R-484D	REAR MOUNTING BOX - DRIVER'S SIDE	1
6	R-4804P	REAR MOUNTING BOX - PASSENGER'S SIDE	1
7	R-4818	HYDRAULIC CYLINDER SUPPORT	2
8	R-4800D-A	OUTER TUBE ASSY., DRIVER'S SIDE	1
9	R-4800P-A	OUTER TUBE ASSY., PASSENGER'S SIDE	1
10	R-18094	O-RING	2
11	R-18090	CAP, REAR INNER GUIDE	2
12	R-3602A	SHIM	8
13	R-3618	SPLIT BEARING	4
14	R-4809	REAR BEARING BOX	2
15	R-3602C	BEARING END CAP	4
16	R-18061	SPACER, HUBCAP	4
17	R-18062	HUBCAP	4
18	R-4588A	SPRING PLATE, REAR	2
19	R-4820	LOCK UP MTS FRAME	1
20	S-002002	SINGLE PILOT OPERATED CHECK VALVE	2
21	R-3590	BELLOWS	2
22	R-602	BELLOWS CLAMP	2
23	R-18101	MACHINE SCREW, #10-32 x 5/8"	16
24	R-18092	WASHER, FENDER	2
25	LOCK WASHER	#10, SPLIT, REG. GR. 8	16
26	FWASHER	1/2" TYPE A, GR. 8	40
27	FWASHER	5/8" TYPE A, GR. 8	16
28	FWASHER	3/4" TYPE A, GR. 8	12
29	HEX JAM NUT	1" UNC, GR. 8, THIN	2
30	NYLOCK NUT	1/2" UNC, GR. 8	20
31	NYLOCK NUT	5/8" UNC, GR. 8	8
32	NYLOCK NUT	3/4" UNC, GR. 8	6
33	NYLOCK NUT	1" UNC, GR. 8	2
34	H.H.C.S	1/2" UNC GR. 8 X 1.75" Lg	12
35	H.H.C.S	1/2" UNC GR. 8 X 2" Lg	8
36	H.H.C.S	5/8" UNC GR. 8 X 2.00" Lg	8
37	H.H.C.S	3/4" UNC GR. 8 X 3.00" Lg	2
38	H.H.C.S	3/4" UNC GR. 8 X 5.5" Lg	4
39	NPT PLUG	1/8" NPT SOCKET HEAD PLUG	4
40	990900-008	1/8 NPT ST. Zerk	4
41	GREASE ZERK	1/8 NPT ST. RELIEF	2
42	R-18102	ST. GREASE ZERK CAP (NOT SHOWN)	1
43	R-18102	1/8 NPT ST. ZERK	1
44	990900-009	1/8 NPT ST. ZERK	8

DETAIL A
ASSEMBLE UPPER PIVOT BOLT AS SHOWN TYP

COAT THREADS WITH ANTI-SEIZE COMPOUND

DO NOT OVERTIGHTEN
DO NOT PINCH CLEVIS
TYP

ALL WELDS TO CONFORM TO AWS D1.1

REVISION	DATE	BY	APPRVD	ECH #
A	05/06/08	JMP		
B	5/27/16	AVIL		
C	12/04/19	SDB	JMP	

REVISION	DESCRIPTION OF CHANGES
A	REVISION A RELEASED
B	REUSED ITEMS ZT, AND ZZ
C	UPDATED BOM TO MATCH MASTER

DATE	BY	APPRVD	ECH #
05/06/08	JMP		
5/27/16	AVIL		
12/04/19	SDB	JMP	

G & B SPECIALTIES INC.
MANUFACTURER OF QUALITY RAILROAD PRODUCTS
BERWICK, PENNSYLVANIA (670) 752-5901, FAX (670) 752-6397

DESIGN - ENGINEERING - MANUFACTURING

R-450 ROTARY REAR GENERATOR

05/06/08 R-4836G

1 R-4836G

05/06/08 R-4836G

REVISION C

NOTES:
1. HARDWARE REF: R-990KIT-240
2. HYDRAULIC REF: H-990KIT-004 (NOT SHOWN FOR CLARITY)
3. APPROX. WEIGHT 409 LBS

BILL OF MATERIAL/PARTS LIST		
ITEM	QTY	DESCRIPTION
1	1	10" WHEEL SUB-ASSEMBLY, MODIFIED ASSEMBLY
2	2	TAPERED ROLLER BEARING CONE (LM104949)
3	1	TAPERED ROLLER BEARING CUP (LM104911)
4	1	SLOTTED WASHER
5	1	OIL SEAL (#471271)
6	1	10" WHEEL Gasket
7	1	10" STEEL WHEEL
8	1	HUB CAP ASSEMBLY (10" WHEEL)
9	1	FITTING, 1/8" STR PTF
10	3	SCREW, 1/4"-28 X 3/4" GR 8 HEX Z/Y
11	3	WASHER, 1/4" HVY LOCK Z/Y
12	1	COTTER PIN, 5/32" X 1 1/4" Z/Y
13	1	NUT, 3/4"-16 UNF REG HEX SLOTTED Z/Y

NOTES:

- ASSEMBLE AS SHOWN.
- BEARINGS ARE TO BE PACKED WITH GREASE AT ASSEMBLY. USE MYSTIK JT-6 LOW TEMP GREASE OR EQUIVELANT.
- BEARING TORQUE PROCEDURE:
 - While rotating the rail wheel forward, torque the bearing nut to 20 ft-lbs., loosen nut and repeat.
 - Loosen the bearing nut and re-torque to 6 ft-lbs.
 - Check bearing end play with a magnetic dial indicator. End play should be within 0.001" - 0.005"
 - If bearing end play is not within the required specification, bearings should be re-torqued following the procedure outlined in steps A thru C.

ASSEMBLE WITH BLUE LOCTITE

REV/DESCRIPTION OF CHANGES	DATE	BY	APPRV'D	ECN #
E. ADDED ITEM #1 - REVISED BOM	12/01/06	ANIL		ECN-17-466
F. UPDATED BOM AND BOARDER	08/14/17	SWMM	JMP	ECN-18-423
G. ADDED NOTE ON WHEEL HUB	05/22/18	JEV	JMP	ECN-18-423
H. REVISED DRAWING; ADDED GREASE NOTE	04/14/21	SWMM	JMP	ECN-21-210

APPROVED	CHECKED	DATE DRAWN	PART NUMBER	REVISION
			10" WHEEL ASSEMBLY	H

1	R001	12/01/06	R-001	
---	------	----------	-------	--

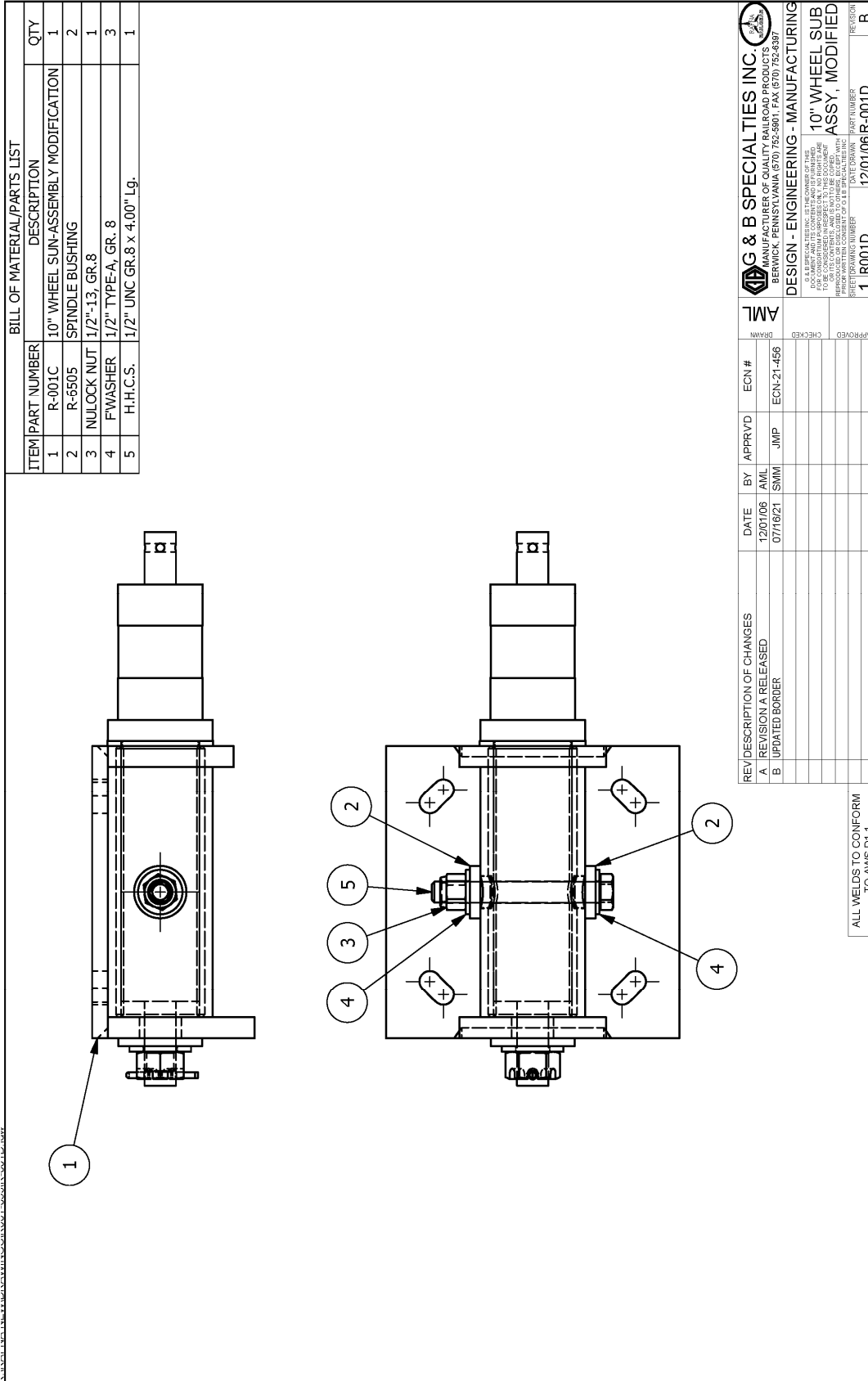

G & B SPECIALTIES INC.
MANUFACTURER OF QUALITY RAILROAD PRODUCTS
BERWICK, PENNSYLVANIA (570) 752-5901, FAX (570) 752-6397

DESIGN - ENGINEERING - MANUFACTURING

10" WHEEL SUB ASSY, MODIFIED

SHEET/DRAWING NUMBER 1 R001D DATE DRAWN 12/01/06 R-001D REVISOR B

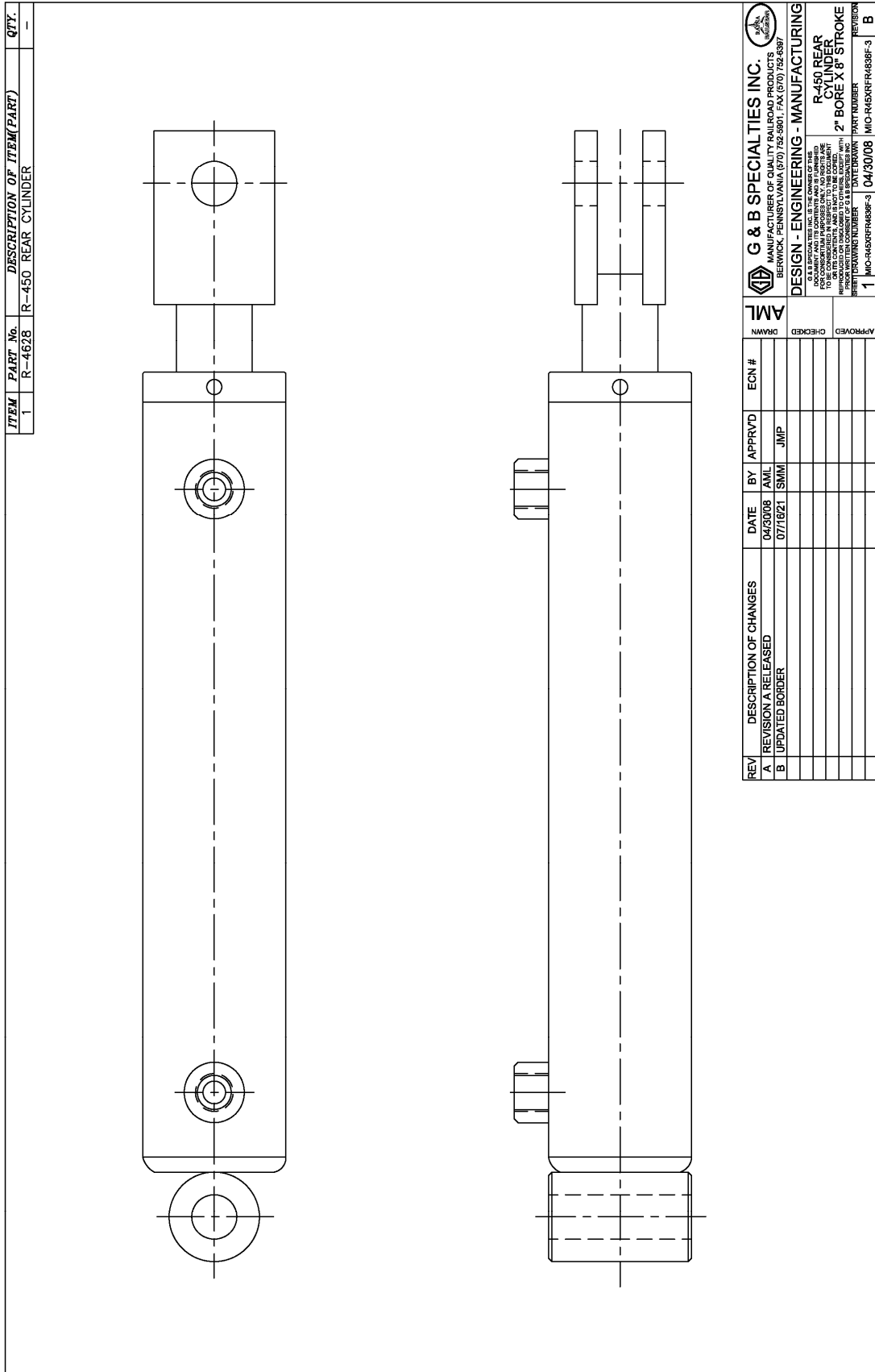

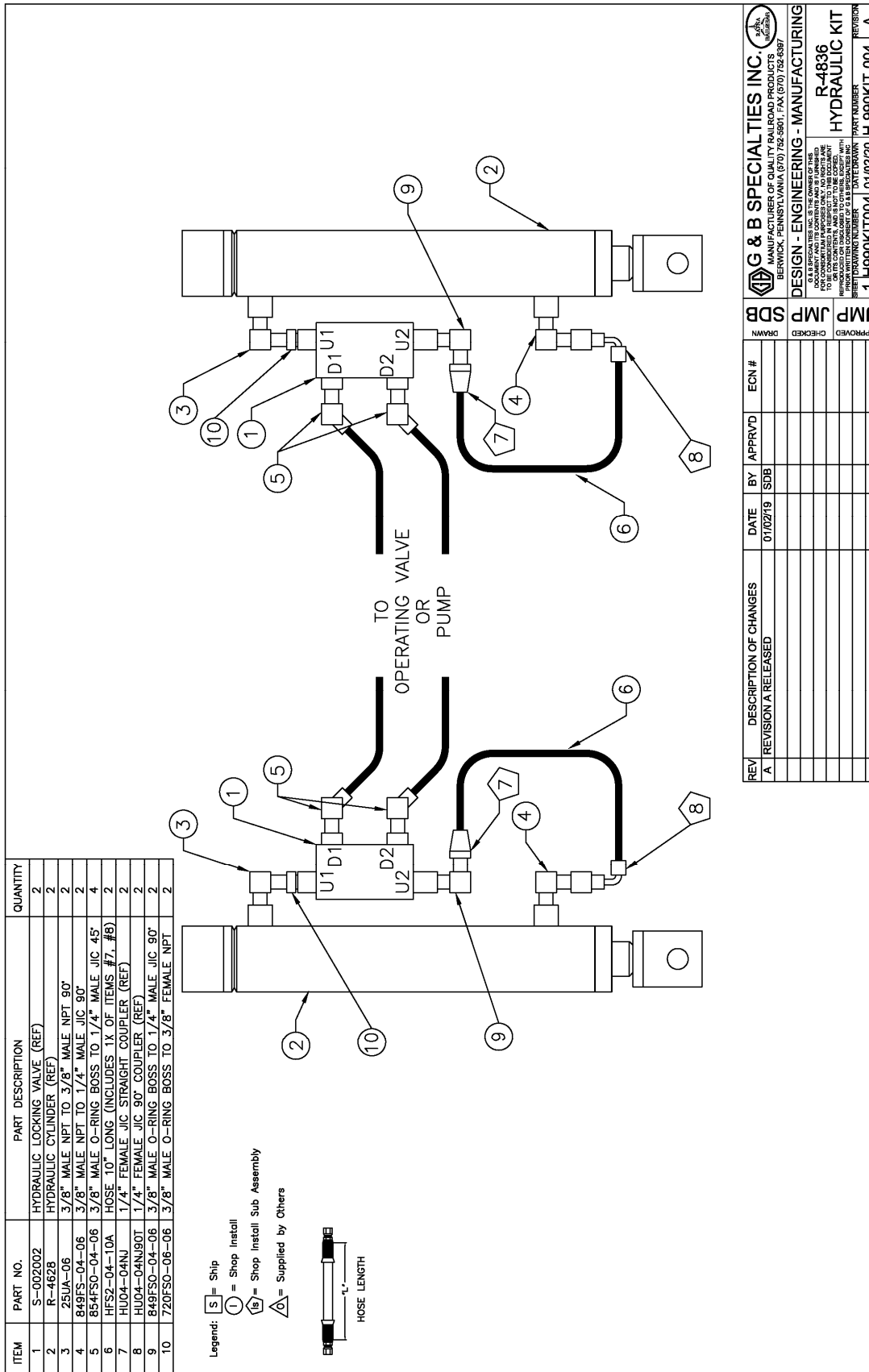

REV	DESCRIPTION OF CHANGES	DATE	BY	APPRVD	ECN #	APPROVED
A	REVISION A RELEASED	01/02/19	SDB			

G & B SPECIALTIES INC.
 MANUFACTURER OF QUALITY RAILROAD PRODUCTS
 BERWICK, PENNSYLVANIA (970) 752-5901, FAX (970) 752-6397

DESIGN - ENGINEERING - MANUFACTURING

JMP JMP SDB
 DRAWN CHECKED APPROVED

R-4836
HYDRAULIC KIT

1 H990KIT004 01/02/20 H-990KIT-004 A

PARTS LIST			
ITEM	PART NUMBER	DESCRIPTION	QTY
1	R-4644L	LEFT RAIL SWEEP BRACKET	1
2	R-2411	RUBBER SWEEP	1
3	R-5561	SWEEPER PLATE	1
4	H.I.C.S	1/4" X 1 1/4" LG, UNC, GR.8	2
5	F WASHER	1/4" TYPE A, GR.8	4
6	NYLOCK NUT	1/4" UNC, GR.8	2

REV/DESCRIPTION OF CHANGES	DATE	BY	APPRVD	ECN #
0. REVISION A RELEASED	03/15/09	V.Z		
A. ITEM 3 WAS R-1001	07/29/02	V.Z		
B. REMOVED NOTE	12/20/06	A.H		
C. UPDATED ITEM 1	08/27/08	J.M.P		
D. UPDATED TITLE BLOCK	08/29/19	S.B.B	J.M.P	ECN-19-554

ALL WELDS TO CONFORM TO AWS D1.1

NOTES:
1. HARDWARE KIT REF: R-990KIT-007
2. APPROX. WEIGHT: 4.3 LBS

G & B SPECIALTIES INC.	
NEWARK, PENNSYLVANIA (570) 752-5901 FAX (570) 752-6397	
BERWICK, PENNSYLVANIA (570) 752-5901 FAX (570) 752-6397	
DESIGN - ENGINEERING - MANUFACTURING	
DO NOT REPRODUCE OR TRANSMIT IN ANY FORM OR BY ANY MEANS, ELECTRONIC OR MECHANICAL, INCLUDING PHOTOCOPYING, RECORDING, OR BY ANY INFORMATION STORAGE AND RETRIEVAL SYSTEM, WITHOUT PERMISSION IN WRITING FROM G&B SPECIALTIES INC.	
APPROVED	DATE DRAWN
CHECKED	PART NUMBER
DRAWN	1 R4646L
	03/15/99/R-4646L
	D

PARTS LIST			
ITEM	PART NUMBER	DESCRIPTION	QTY
1	R-4644R	RIGHT RAIL SWEEP BRACKET	1
2	R-2411	RUBBER SWEEP	1
3	R-5561	SWEEPER PLATE	1
4	H.H.C.S	1/4" X 1 1/4" UNC, GR.8	2
5	F WASHER	1/4" TYPE A, GR.8	4
6	NYLOCK NUT	1/4" UNC, GR.8	2

G & B SPECIALTIES INC.	
MANUFACTURER OF QUALITY RAILROAD PRODUCTS BERWICK, PENNSYLVANIA (570) 752-5901, FAX (570) 752-6397	
DESIGN - ENGINEERING - MANUFACTURING	
THIS DRAWING AND THE CONTENTS AND DIMENSIONS THEREOF ARE THE PROPERTY OF G&B SPECIALTIES INC. AND ARE TO BE CONSIDERED IN CONFIDENCE. ANY REPRODUCTION OR DISCLOSURE TO OTHERS WITHOUT THE WRITTEN PERMISSION OF G&B SPECIALTIES INC. IS STRICTLY PROHIBITED.	DATE DRAWN: 07/10/07 PART NUMBER: R-4646R REVISION: C

NOTES:
1. HARDWARE KIT REF: R-990KIT-007
2. APPROX. WEIGHT: 4.3 LBS

ALL WELDS TO CONFORM TO AWS D1.1

6.0 HYDRAULIC KIT (HYDRAULIC PUMP & PTO)

INSTALLATION SAFETY PRECAUTIONS

If any installation problems are encountered, please call G&B Specialties, Inc. for technical assistance before continuing with the installation process.



- Failure to heed to any of the following warnings could result in severe bodily injury and/or equipment damage.
- Read and understand this manual completely before attempting installation or operation of the equipment.
- Installation/Operation instructions provided below only address the Rafna railgear equipment. Applicable railway company procedures and policies must be adhered to.
- Before performing any work under the vehicle or railgear, ensure the engine is turned off and the parking brake is set.
- When routing hydraulic hoses, ensure that the hoses do not contact any sharp edges or hot surfaces.
- When routing electrical wires, ensure that the wires do not contact any sharp edges or hot surfaces.
- All wire connections are to be soldered and heat shrink sealed to prevent future corrosion related problems.
- All wires must be covered with protective cable loom.
- Railway company rules governing rail travel must always be observed.
- Ensure all body parts and loose clothing are clear of any moving parts of the railgear. Be aware of all pinch points.
- Note that if the railgear is part way retracted or extended, opening the manifold directional valve manual over-rides may cause the railgear to drop suddenly causing personal injury. Ensure all body parts are clear of the railgear if it should suddenly drop.
- When operating the railgear using the emergency hand pump, ensure that the correct manual valve over-ride is open for the desired railgear (front or rear) and desired direction of operation (raise or lower).
- Do not use the emergency hand pump to raise and lower the railgear on a routine basis. If the hydraulic pump or manifold should fail, have it repaired as soon as possible.

- If the emergency hand pump has been used to raise or lower the railgear, ensure the manifold directional valve manual over-rides are in the closed and locked position before starting road or rail travel.
- Ensure the hydraulic pump has been de-energized before starting road or rail travel.

INSTALLATION OF HYDRAULIC KIT W/ PUMP

The following procedure details the installation of the hydraulic kit. The hardware required for this installation is listed in Table 1.

Table 1: Hydraulic Kit Installation Parts

Part Number	Description	Qty
R-060	Railgear Hydraulic Pump	1
R-19048	Control Mounting Plate	2
R-2837	Pump Mounting Bracket	1
CO-106	Dash Switch	1
R-1577	5 Amp In-Line Fuse	1
R-1577-1	5 Amp Automotive Fuse	1
CO-130G	"Railgear Pump" Decal	1
H-990KIT-011	1/4" Male JIC to 3/8" Male O-Ring Boss	4
	1/4" Male JIC to 1/4" Male JIC Tee	2
	1/4" Female JIC Straight Coupler (Installed on hoses)	12
	1/4" Female JIC Coupler 90° (Installed on hoses)	4
	Hydraulic Hose 20" Long	2
	Hydraulic Hose 33" Long	2
	Hydraulic Hose 32" Long	2
R-990KIT-023	Hydraulic Hose 360" Long	2
	3/8" UNC Gr. 8 Bolt x 1" Long	2
	3/8" SAE Washer	2
	3/8" Lock Washer	2

1. Remove the motor solenoid from the pump. Re-install the solenoid retaining screws into the pump to prevent water from entering the pump motor.
2. Install the solenoid in a suitable location under the hood near the vehicle's battery with hardware supplied by the installer. Ensure that the solenoid's body is electrically grounded.
3. Note that the pump is fastened to the pump bracket by two 3/8" fasteners on the bottom of the pump. Align the pump and pump mounting bracket as shown prior to welding and ensure that the pump will not block the vehicle's lights and that the tank end of the pump is accessible to fill. Make sure the emergency hand pump assembly is easily accessible and has clearance to operate through its full stroke.
 - a) Once location is found, weld the pump bracket as shown.
 - b) Paint welds once cool to prevent rusting.
 - c) Fasten the pump to the pump mounting bracket using two 3/8" x 1" long bolts, two 3/8" lock washers and two 3/8" flat washers. Torque the 3/8" fasteners to 40 ft-lbs dry. Do not over torque.
4. Install a 1/4" JIC to 3/8" O-Ring Boss fitting in each of the four pump pressure ports.
5. Connect one 32" long hose between the upper 'A' port of the pump and the 'D1' port of the front railgear Double P.O. check valve. The 90° hose end should be at the pump.

6. Connect one 32” long hose between the upper ‘B’ port of the pump and the ‘D2’ port of the front railgear Double P.O. check valve. The 90° hose end should be at the pump.
7. Connect one 33” long hose to the ‘D1’ port of the rear railgear right-hand side single P.O. check valve.
8. Connect one 33” long hose to the ‘D2’ port of the rear railgear right-hand side single P.O. check valve.
9. Connect one 1/4” male JIC to 1/4” male JIC tee fitting to the loose end of each of the two 33” long hoses.
10. Connect one 20” long hose between the ‘D1’ port of the rear railgear left-hand side single P.O. check valve and the tee fitting on the 33” long hose connected to the ‘D1’ port of the rear railgear right-hand side single P.O. check valve.
11. Connect one 20” long hose between the ‘D2’ port of the rear railgear left-hand side single P.O. check valve and the tee fitting on the 33” long hose connected to the ‘D2’ port of the rear railgear right-hand side single P.O. check valve.
12. Connect one 360” long hose to the lower ‘A’ port on the pump. The 90° hose end should be at the pump. Mark the end of this hose “D1”.
13. Connect one 360” long hose to the lower ‘B’ port on the pump. The 90° hose end should be at the pump. Mark the end of this hose “D2”.
14. Route the two 360” long hydraulic hoses to the rear of the vehicle along the left side of the frame and secure in place. Where necessary, fasten the hose to the frame with installer-supplied hose clips and hardware.
15. Connect the end of the hose marked “D1” to the tee fitting connected between the ‘D1’ ports of the rear railgear check valves.
16. Connect the end of the hose marked “D2” to the tee fitting connected between the ‘D2’ ports of the rear railgear check valves.
17. Ensure that none of the hoses contact any sharp edges or hot surfaces. Secure these hoses in place. Ensure that there is enough slack in the hoses for the railgear to function.
18. Install the dash switch and “Railgear Pump” decal in a convenient location on the dash.
19. The pump has two wire harnesses and two wires connected to it:
 - a) One 36’ wire harness for the front railgear with a control box on the end.
 - b) One 36’ wire harness for the rear railgear with a control box on the end.
 - c) One white and one black wire each with ring terminals on the ends.

20. Using suitable 14 gauge wire, cable loom, connectors, solder and heat shrink tubing:

- a) Lengthen the white wire if required and connect it from the pump to the switching terminal on the railgear pump solenoid previously mounted under the hood.
- b) Lengthen the black wire if required and connect it from the pump through the firewall to the load terminal on the dash switch.
- c) Connect another length of black wire from the power terminal on the dash switch through the firewall to the in-line fuse.
- d) Connect another length of black wire from the in-line fuse to the power terminal on the solenoid.
- e) Connect another wire from the ground terminal on the dash switch to a suitable ground location on the vehicle.

21. Using suitable 4 gauge wire, cable loom, connectors, solder and heat shrink tubing:

- a) Connect one wire from the vehicle's battery to the power terminal on the railgear pump solenoid.
- b) Connect another wire from the load terminal on the solenoid to the power terminal on the pump motor. Use silicone to protect the pump power terminal from shorting out.
- c) Ensure the pump motor base is properly grounded to the vehicle chassis by connecting a wire from the pump motor base to a suitable ground location on the vehicle. The railgear may not be properly grounded due to paint on the mounting plates or tar on the frame.

22. Route one of the 36' wire harness from the pump along the frame to the rear of the vehicle and secure in place. If necessary, the control box can be removed from and reinstalled on the wire harness to facilitate routing. Fabricate a bracket and mount the rear railgear control box with installer-supplied hardware in a protected vertical position in a suitable location. Ensure the control box is within reach of the railgear locking cable handle.

23. Route the other 36' wire harness from the pump to the front of the vehicle and secure in place. If necessary, the control box can be removed from and reinstalled on the wire harness to facilitate routing. Wire harness can be shortened once mounting location is determined. Fabricate a bracket and mount the front railgear control box with installer-supplied hardware in a protected vertical position in a suitable location. Ensure the control box is within reach of the railgear lock hook handle.

24. Ensure that the control boxes are mounted vertically so that the controls do not fill with water and freeze. They should also be mounted in a location protected from road spray etc.

25. Ensure all wires and terminals are soldered, heat shrink sealed, enclosed in protective cable loom and secured.

26. Ensure all holes in the firewall are sealed and protected with a grommet.

27. Fill the hydraulic system and bleed the air out:

- a) Fill the pump tank with **DEXRON III** (or equivalent) hydraulic fluid.
- b) Operate the front railgear up and down briefly to circulate the fluid and bleed the system of air (refer to the Railgear Kit and Hydraulic Kit Operation, Service, and Parts manuals for operation instructions).
- c) Refill the pump tank and repeat the above step until all air is removed from the front hydraulic system.
- d) Operate the rear railgear up and down briefly to circulate the fluid and bleed the system of air (refer to the Railgear Kit and Hydraulic Kit Operation, Service, and Parts manuals for operation instructions).
- e) Refill the pump tank and repeat the above step until all air is removed from the rear hydraulic system.
- f) With both front and rear railgear locked in the road position, fill the pump tank to the full line.

28. Follow the Hydraulic System Relief Valve Setting procedure detailed in the Hydraulic Kit Operating, Service and Parts Manual.

29. Test the operation of the controls. Refer to the operation procedure in the Railgear Kit and Hydraulic Kit Operation, Service, and Parts manuals.

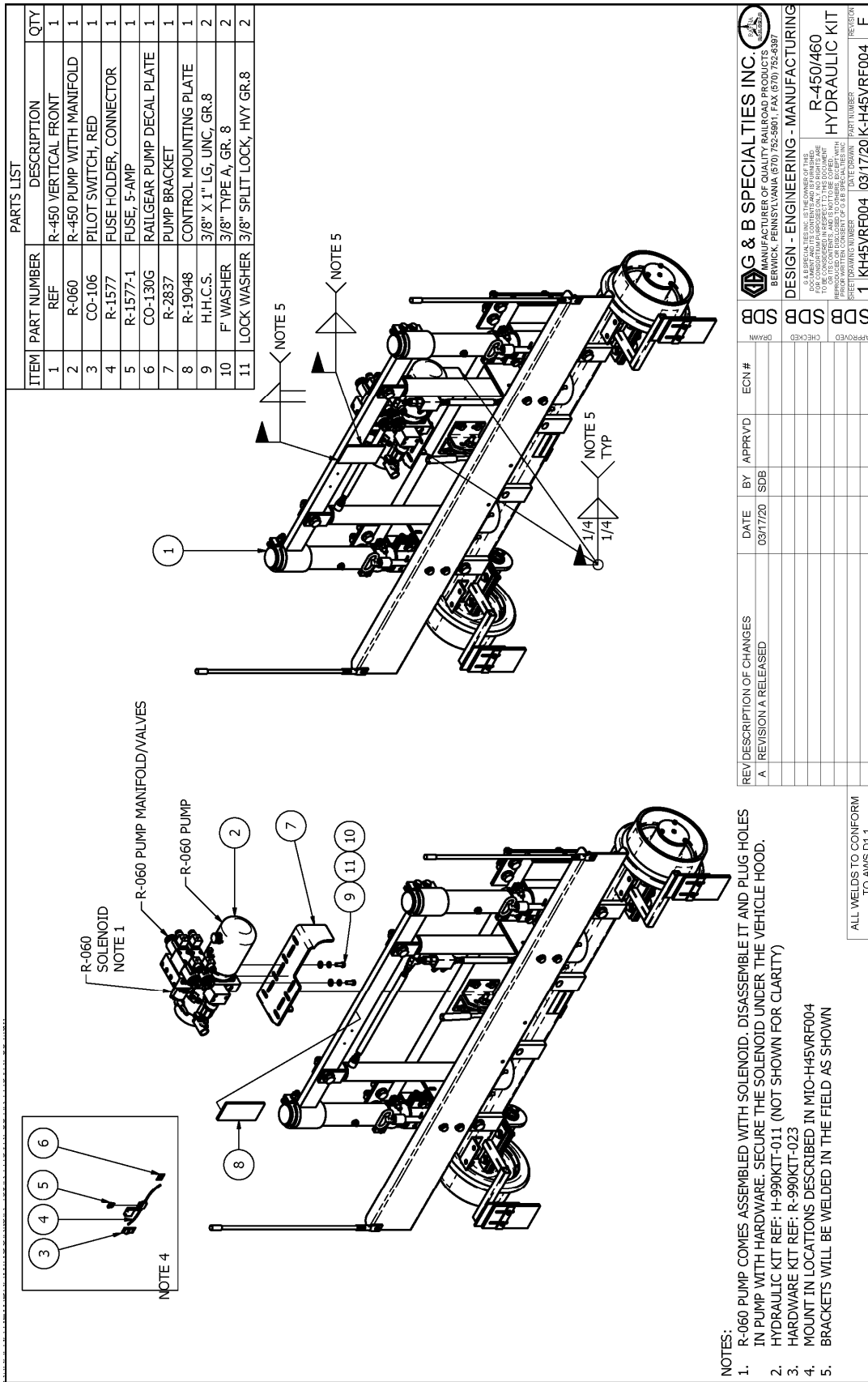

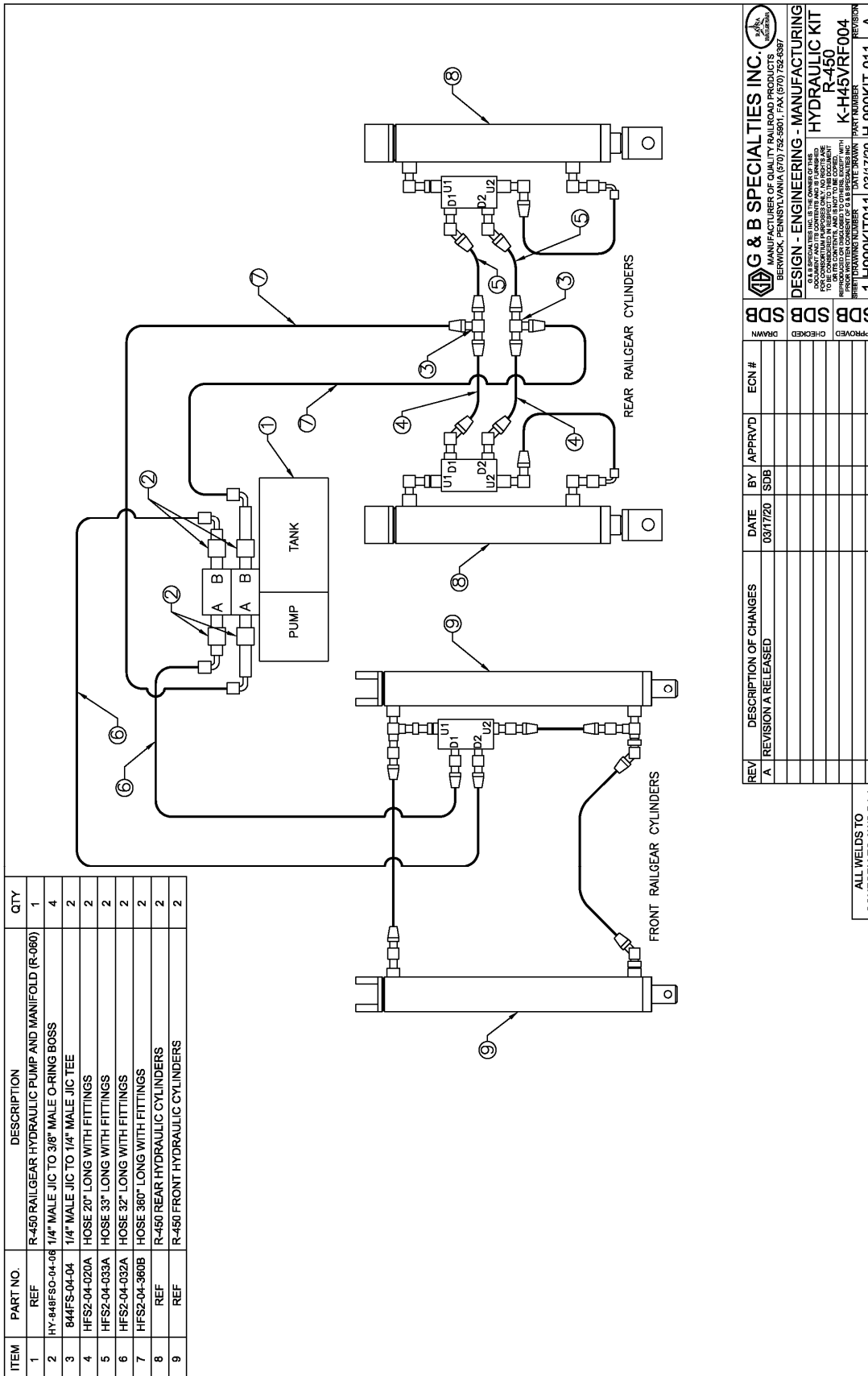

ITEM	PART NO.	DESCRIPTION	QTY
1	REF	R-450 RAILGEAR HYDRAULIC PUMP AND MANIFOLD (R-060)	1
2	HY-848FS0-04-06	1/4" MALE JIC TO 3/8" MALE O-RING BOSS	4
3	844FS-04-04	1/4" MALE JIC TO 1/4" MALE JIC TEE	2
4	HFS2-04-020A	HOSE 20" LONG WITH FITTINGS	2
5	HFS2-04-033A	HOSE 33" LONG WITH FITTINGS	2
6	HFS2-04-032A	HOSE 32" LONG WITH FITTINGS	2
7	HFS2-04-360B	HOSE 360" LONG WITH FITTINGS	2
8	REF	R-450 REAR HYDRAULIC CYLINDERS	2
9	REF	R-450 FRONT HYDRAULIC CYLINDERS	2

REV	DESCRIPTION OF CHANGES	DATE	BY	APPRVD	ECN #
A	REVISION A RELEASED	03/17/20	SDB		

G & B SPECIALTIES INC.
 MANUFACTURER OF QUALITY RAILROAD PRODUCTS
 BERWICK, PENNSYLVANIA (570) 752-5901, FAX (570) 752-6397
 DESIGN - ENGINEERING - MANUFACTURING
HYDRAULIC KIT
R-450
K-H45VRF004
 SHEET DRAWING NUMBER DATE: 03/17/20 PART NUMBER
1 H-990KIT011 03/17/20 H-990KIT-011 A

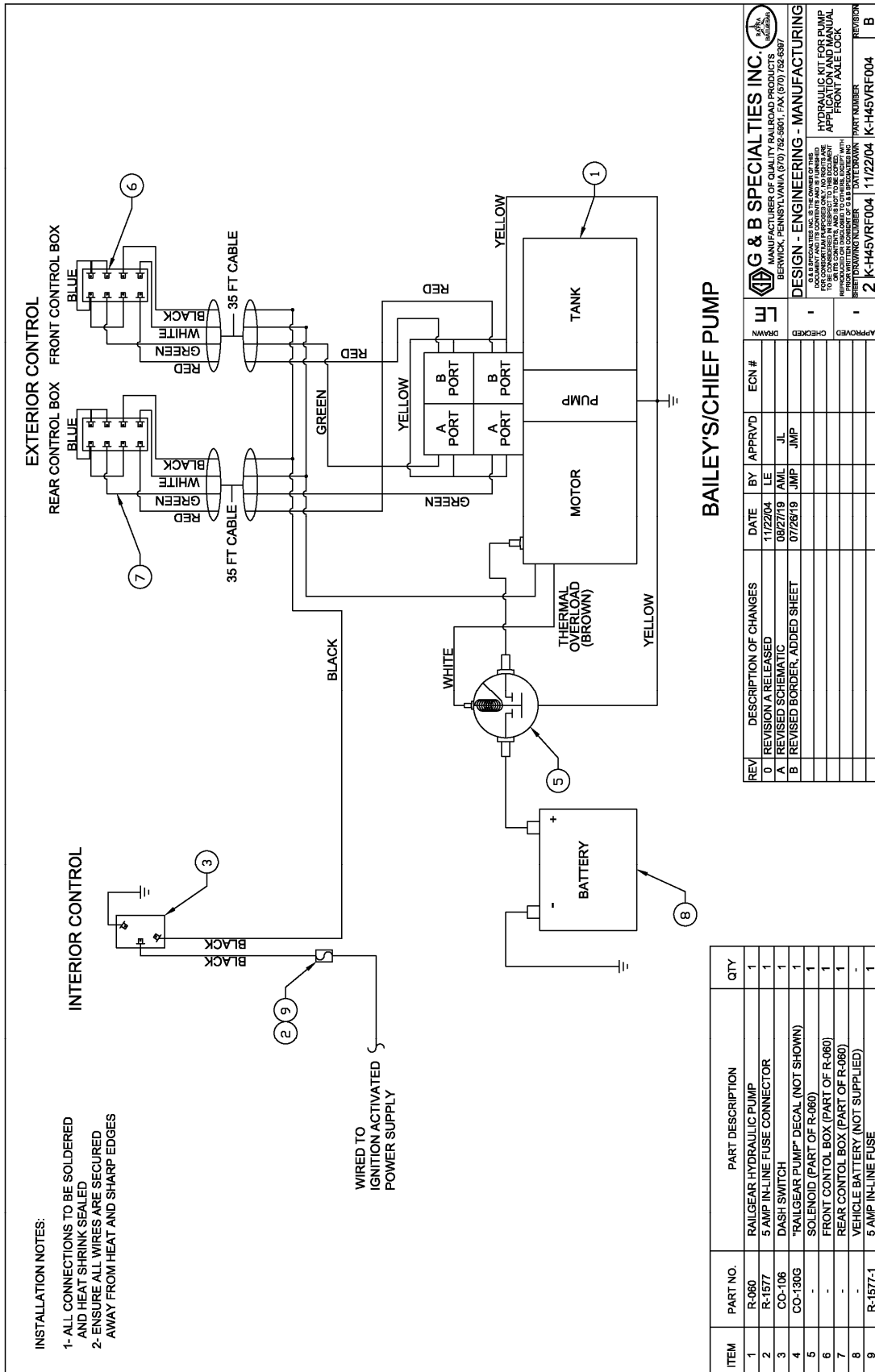

ITEM	PART NO.	PART DESCRIPTION	QTY
1	R-060	RAILGEAR HYDRAULIC PUMP	1
2	R-1577	5 AMP IN-LINE FUSE CONNECTOR	1
3	CO-106	DASH SWITCH	1
4	CO-130G	"RAILGEAR PUMP" DECAL (NOT SHOWN)	1
5	-	SOLENOID (PART OF R-060)	1
6	-	FRONT CONTROL BOX (PART OF R-060)	1
7	-	REAR CONTROL BOX (PART OF R-060)	1
8	-	VEHICLE BATTERY (NOT SUPPLIED)	-
9	R-1577-1	5 AMP IN-LINE FUSE	1

REV	DESCRIPTION OF CHANGES	DATE	BY	APPRVD	ECN #	APPROVED	CHECKED	DRWN
0	REVISION A RELEASED	11/22/04	LE	JL				
A	REVISED SCHEMATIC	08/27/19	AML	JL				
B	REVISED BORDER, ADDED SHEET	07/29/19	JMP	JMP				

DESIGN - ENGINEERING - MANUFACTURING	DATE	BY	APPRVD
DESIGN - ENGINEERING - MANUFACTURING	11/22/04	LE	JL

REVISION NUMBER	DATE	BY	APPRVD
2	11/22/04	K-H4SVRF004	B

OPERATION/SERVICE SAFETY PRECAUTIONS

If any operating, service or parts problems are encountered, please call G&B Specialties, Inc. for technical assistance.



- Failure to heed to any of the following warnings could result in severe bodily injury and/or equipment damage.
- Read and understand this manual completely before attempting operation of the railgear equipped vehicle.
- Operating instructions provided below only address the Rafna railgear equipment. Applicable railway company procedures and policies must be adhered to.
- Railway Company rules governing rail travel must be observed at all times.
- Before performing any work under the vehicle or railgear, ensure the engine is turned off and the parking brake is set.
- Ensure all body parts and loose clothing are clear of any moving parts of the railgear. Be aware of all pinch points.
- Note that if the railgear is part way retracted or extended, opening the manifold directional valve manual over-rides may cause the railgear to drop suddenly causing personal injury. Ensure all body parts are clear of the railgear if it should suddenly drop.
- When operating the railgear using the emergency hand pump, ensure that the correct manual valve over-ride is open for the desired railgear (front or rear) and desired direction of operation (raise or lower).
- Do not use the emergency hand pump to raise and lower the railgear on a routine basis. If the hydraulic pump or manifold should fail, have it repaired as soon as possible.
- If the emergency hand pump has been used to raise or lower the railgear, ensure the manifold directional valve manual over-rides are in the closed and locked position before starting road or rail travel.
- Ensure the hydraulic pump has been de-energized before starting road or rail travel.

OPERATION OF HYDRAULIC KIT (PUMP)

With the hydraulic kit installed on this vehicle, it may be operated as normal.

Never operate the vehicle if the Gross Vehicle Weight Rating (GVWR), Gross Axle Weight Rating Front or Rear (GAWR), or the wheel or tire load ratings are exceeded.

Refer to the Railgear Kit Operation, Service and Parts manual for information on the mechanical operation, service and parts of the railgear.

Location and Operation of the Railgear Hydraulic System Controls:

The railgear hydraulic system consists of a hydraulic pump, a front control box and a rear control box.

1. The railgear hydraulic pump must be energized prior to use by turning on the respective dash switch. At this point the dash switch light should come on but the pump should not run and the railgear should not move until a control button is depressed.
2. The direction of the front or rear railgear movement is selected by pushing the “Up” or “Down” button on the respective control box located near the railgear. At this point the pump should start and the railgear should move in the selected direction.
3. To stop the movement of the railgear, release the depressed button.
4. The pump must be de-energized after use by turning off the respective dash switch. At this point the pump should not be able to run and the control buttons should be in-active.

SERVICE OF HYDRAULIC KIT

The hydraulic kit must be serviced regularly to avoid damage to the equipment. Table 1 below provides the Recommended Service Schedule and Table 2 provides Standard Fastener Torque Values.

The recommended oil for the railgear hydraulic system is **DEXRON III** or equivalent. In extremely cold weather areas/seasons, **Tellus S4 VX32** or equivalent may be used.

Table 1: Recommended Service Schedule

Service Required	Initial 100 km (62 Miles) of road and/or rail use	Daily	Weekly	Monthly
Inspect hydraulic kit fasteners (re-torque if required)		✓	✓	✓
Inspect all hydraulic fittings and hoses for leaks and wear		✓	✓	✓
Check oil in hydraulic reservoir (fill with railgear raised if req'd)				✓
Check emergency hand pump and manifold over-ride operation				✓

Table 2: Standard Fastener Torque Values

Fastener Size	Fastener Torque Value (ft-lbs) Dry
1" UNC Gr. 8 Fasteners	250
¾" UNC Gr. 8 Fasteners	175
⅝" UNC Gr. 8 Fasteners	150
½" UNC Gr. 8 Fasteners	100
⅜" UNC Gr. 8 Fasteners	40
¼" UNC Gr. 8 Fasteners	12

HYDRAULIC SYSTEM RELIEF VALVE SETTING

This system is equipped with one relief valve located on the railgear pump body. This relief valve protects the entire hydraulic system from over pressurization. The relief valve will require adjustment at installation and if ever there appears to be inadequate hydraulic pressure to operate the railgear.

1. Disconnect the hydraulic hose from the upper “B” port on the pump.
2. Install a hydraulic pressure gauge (up to 3000 PSI) between the disconnected hydraulic hose and the pump port. The pressure gauge will indicate the relief valve setting when the pump is loaded.
3. Following the procedure in the Railgear Kit Operation, Service and Parts manual, raise the front railgear completely and continue to raise the railgear so that the hydraulic cylinder creates a load on the pump by trying to “dead-head”. The pressure reading on the pressure gauge should climb to 1800 PSI.
4. If the pressure is not correct, release the railgear controls and adjust the relief valve on the pump accordingly. Loosen the lock nut and turn the setscrew in to increase the pressure or out to decrease the pressure. Re-check the pressure.
5. Once the correct pressure on the pump relief valve is obtained, ensure the lock nut on the relief valve is tightened. Release the pressure in the system and remove the pressure gauge. Re-connect all hydraulic hoses.
6. Ensure the railgear is properly raised as per the Railgear Kit Operation, Service and Parts manual.

ELECTRICAL SYSTEM TROUBLESHOOTING

The following basic test can be performed to check the integrity of the railgear electrical system.

Should the railgear pump fail to operate, first check the fuse or the circuit breaker and all wiring for shorts, then the following test can be performed to verify the integrity of the pump motor and pump solenoid.

1. Pump motor test:

- a) Connect one end of a 14-gauge shunt wire to the pump motor power terminal and touch the other end to the battery positive terminal.
- b) The pump motor should run upon touching the shunt wire.
- c) If the pump does not run, the pump is not properly grounded, or the pump motor is defective.
- d) If the pump motor runs, test for a defective solenoid.

2. Solenoid test:

- a) Connect one end of a 14-gauge shunt wire to the switching terminal on the solenoid and touch the other end to the battery positive terminal. If the pump does not operate the solenoid is not properly grounded or it is defective. If the pump operates, the problem lies with the fuse/circuit breaker, wiring and/or switches.

Should the pump start running immediately following turning on the respective dash switch, the following tests can be performed to help locate the problem.

1. Disconnect the wire from the switching terminal on the solenoid. If the pump continues to run, then the solenoid is defective.
2. Check all wiring and switches for shorts and / or loose terminals.

PARTS OF HYDRAULIC KIT

PARTS LIST		
ITEM PART NUMBER	DESCRIPTION	QTY
1 S-309690	MOTOR	1
2 S-309691	BODY VALVE BLOCK	1
3 S-309692	HAND PUMP BLOCK	1
4 S-309693	CONTROL BLOCK	1
5 S-309605	HAND PUMP ASSEMBLY	1
6 S-309652	CHECK VALVE (INTERNAL)	1
7 S-309606	RELIEF	1
8 S-309653	4 WAY 3 POSITION SOLENOID VALVE	2
9 S-309654	SOLENOID	1
10 S-309655	GEAR PUMP	1
11 S-309694	COUPLING (INTERNAL)	1
12 S-309680	TANK	1
13 S-309657	HEX BOLT	3
14 S-309658	HEX BOLT WITH SPRING WASHER	4
15 S-309659	HEX BOLT WITH SPRING WASHER	2
16 S-309615	LONG BOLT	2
17 S-309660	BOLT	2
18 S-309623	CABLE	1
19 S-309624	CABLE COVER	2
20 S-309614	O-RING	4
21 S-309613	O-RING	1
22 S-309661	RESPIRATOR ASSEMBLY	1
23 S-309621	IRON PLUG	4
24 S-309662	PLASTIC PLUG (FOR SHIPPING ONLY)	4
25 S-309663	OIL PIPE	1
26 S-309664	FILTER	1
27 S-309617	OIL RETURN PIPE	1
28 S-309665	SUCTION OIL PIPE	1
29 S-309612	MAGNET	1
30 S-309634	CONTROL BOX ASSEMBLY (SHEET 2)	2
31 S-309667	CABLE, BLACK (18", SHEET 2)	1
32 S-309668	CABLE, WHITE (18", SHEET 2)	1
33 S-309669	CONNECTING CABLE (12", SHEET 2)	1
34 S-309627	HAND PUMP OPERATING ROD	1
35 S-309628	ROD COVER	1
36 S-309638	CABLE GLAND (SHEET 2)	2

REV	DESCRIPTION OF CHANGES	DATE	BY	APPRVD	ECN #
A	REVISION A RELEASED	03/18/20	SDB		
B	UPDATED PART NUMBERS	07/15/20	SMM		
C	UPDATED PUSH BUTTON PART NUMBER	08/19/20	SMM		

G & B SPECIALTIES INC.
 MANUFACTURER OF QUALITY RAFFAELLO PRODUCTS
 BERWICK, PENNSYLVANIA (570) 752-5901, FAX (570) 752-6397
 DESIGN - ENGINEERING - MANUFACTURING
 BAILEY R-060
 HYDRAULIC PUMP
 PARTS BREAKDOWN
 DATE DRAWN: 03/18/20
 PART NUMBER: R-060
 REVISION: C

NOTES:
 1. SEE SHEET 2 FOR HYDRAULIC SCHEMATIC AND ELECTRICAL CONNECTION INSTRUCTIONS
 2. TO BE USED WITH BAILEY PUMPS ONLY

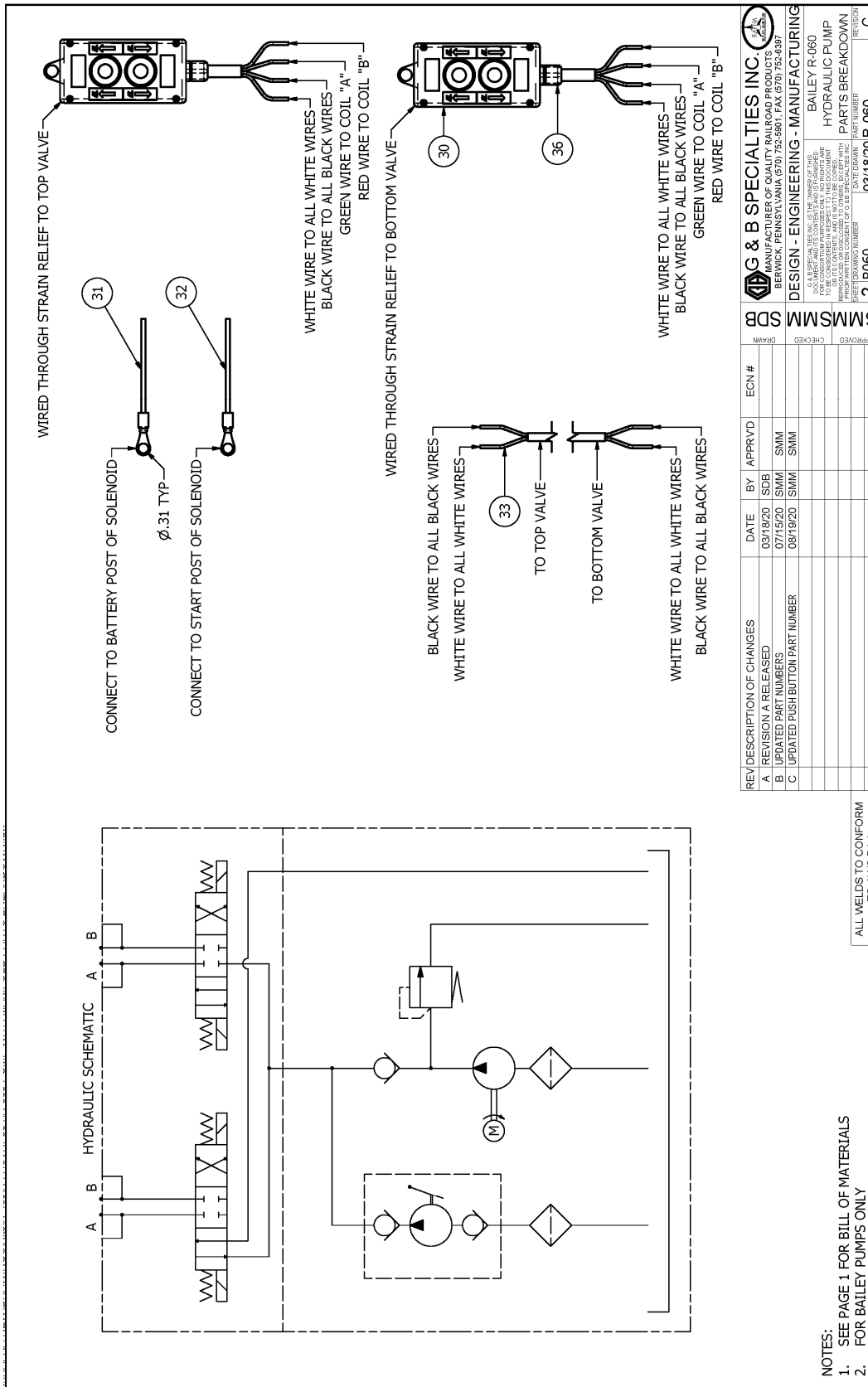

DB	MANUFACTURER OF QUALITY RAILROAD PRODUCTS	BAILEY R-080
SDB	DESIGN - ENGINEERING - MANUFACTURING	HYDRAULIC PUMP
SMM	FOR CONSULTATION PURPOSES ONLY. THE RIGHT OF FIRST REFERENCE IS RESERVED. THIS DRAWING IS THE PROPERTY OF G&B SPECIALTIES, INC. IT IS TO BE USED ONLY FOR THE PROJECT AND PART TO BE CONSTRUCTED. IT IS NOT TO BE REPRODUCED, COPIED, OR TRANSMITTED IN ANY FORM OR BY ANY MEANS, ELECTRONIC OR MECHANICAL, INCLUDING PHOTOCOPYING, RECORDING, OR BY ANY INFORMATION STORAGE AND RETRIEVAL SYSTEM.	PARTS BREAKDOWN
DB	REV NUMBER	REV NUMBER
2	R060	03/18/20 R-080
C		

INSTALLATION OF HYDRAULIC FOR PTO APPLICATIONS

The following procedure details the installation of the hydraulic kit. The hardware required for this installation is listed in Table 1.

Table 1: Hydraulic Kit Installation Parts

Part Number	Description	Qty
S-802020	Operating Valve	2
R-559-11	Operating Valve Handle	2
R-1013	Operating Valve Mounting Plate	2
R-2407	Operating Valve Bracket	1
R-32231	Fitting, 1/4" X 1/4" JIC Swivel 90°	4
R-32230	Fitting, 1/4 Male JIC X 1/2" Male O-Ring	4
H-990KIT-003	1/4" Male JIC to 3/8" Male O-Ring Boss 90°	2
	1/4" Male JIC to 1/4" Male JIC Tee	2
	1/4" Female JIC Straight Coupler (Installed on Hoses)	12
	Hydraulic Hose 12" Long	2
	Hydraulic Hose 20" Long	2
R-990KIT-027	Hydraulic Hose 33" Long	2
	1/4" UNC Gr. 8 Bolt x 2.25" Long	4
	1/4" SAE Washer	8
Not Supplied	1/4" UNC Gr. 3 Nylock Nut	4
	Hydraulic Hoses, Couplers and Fittings	As Req'd

1. The vehicle's PTO pump should be selected to supply 3-5 gallons per minutes (GPM) of oil at 2000 PSI at the front and rear railgear operating valves. A main relief valve should be installed just after the PTO pump to protect it. For vehicles operating more than just the railgear from the PTO pump, the railgear's hydraulic system should be on a separate circuit dedicated to the railgear. A relief valve should be installed on the railgear hydraulic circuit.
2. The front railgear operating valve is supplied with two 90° fittings installed in the work ports and the rear operating valve is supplied without fittings. Fasten the front railgear operating valve to the mounting holes provided on the railgear upper cross frame using two 1/4" x 2.25" long bolts, four 1/4" washers and two 1/4" nuts. Torque the 1/4" fasteners to 12 ft-lbs dry. Do not over torque.
3. Choose a suitable location on the vehicle to mount the rear railgear operating valve using the supplied weld-on operating valve bracket. Ensure that there will be sufficient room for the operator to stand safely out of the way of moving parts. The operating valve should be installed near the rear railgear within reach of the railgear lock cable handle. Weld the operating valve bracket in place.
4. Fasten the operating valve to the operating valve bracket using two 1/4" x 2.25" long bolts, four 1/4" washers and two 1/4" nuts. Torque the 1/4" fasteners to 12 ft-lbs dry. Do not over torque.
5. Connect one 12" long hose between the upper work port of the front railgear operating valve and the 'D1' port of the front railgear Double P.O. check valve.

6. Connect one 12” long hose between the lower work port of the front railgear operating valve and the ‘D2’ port of the front railgear Double P.O. check valve.
7. Connect one 33” long hose to the ‘D1’ port of the rear railgear right-hand side single P.O. check valve.
8. Connect one 33” long hose to the ‘D2’ port of the rear railgear right-hand side single P.O. check valve.
9. Connect a 1/4” male JIC to 1/4” male JIC tee fitting to the end of each of the 33” long hoses.
10. Connect one 20” long hose between the ‘D1’ port of the rear railgear left-hand side single P.O. check valve and the tee fitting on the 33” long hose connected to the ‘D1’ port of the rear railgear right-hand side single P.O. check valve.
11. Connect one 20” long hose between the ‘D2’ port of the rear railgear left-hand side single P.O. check valve and the tee fitting on the 33” long hose connected to the ‘D2’ port of the rear railgear right-hand side single P.O. check valve.
12. Install appropriate fittings in the upper and lower work ports of the rear railgear operating valve.
13. Fabricate, and connect an appropriate hydraulic hose to reach from the tee fitting located between the ‘D1’ ports of the rear railgear check valves to the upper work port of the rear railgear operating valve.
14. Fabricate, and connect an appropriate hydraulic hose to reach from the tee fitting located between the ‘D2’ ports of the rear railgear check valves to the lower work port of the rear railgear operating valve.
15. Install appropriate fittings in the ‘P’ (pressure) and ‘T’ (tank) ports of the front and rear railgear operating valves.
16. Fabricate, and connect an appropriate hydraulic hose to reach from the railgear hydraulic system pressure line to the front railgear operating valve ‘P’ port.
17. Fabricate, and connect an appropriate hydraulic hose to reach from the front railgear operating valve ‘T’ port to the rear railgear operating valve ‘P’ port.
18. Fabricate, and connect an appropriate hydraulic hose to reach from the rear railgear operating valve ‘T’ port to the vehicle’s hydraulic return line.
19. Ensure that none of the hoses contact any sharp edges or hot surfaces. Secure these hoses in place. Ensure that there is enough slack in the hoses for the railgear to function.
20. Adjust the operating valve relief valve pressure as per the procedure in the Hydraulic Kit Operation, Service and Parts manual.
21. Test the operation of the controls. Refer to the operation procedure in the Railgear Kit and Hydraulic Kit Operation, Service and Parts manuals.

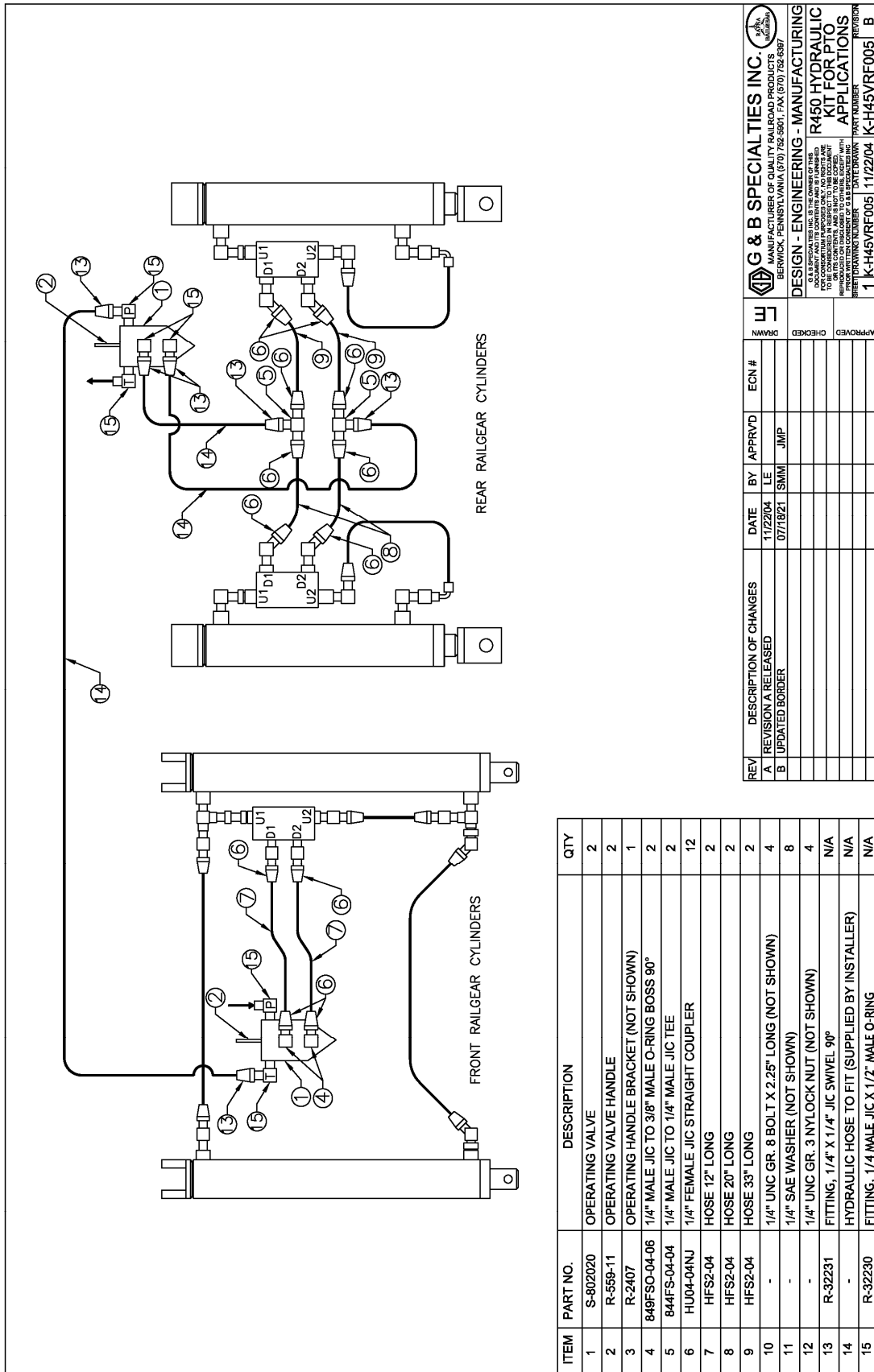

ITEM	PART NO.	DESCRIPTION	QTY
1	S-802020	OPERATING VALVE	2
2	R-559-11	OPERATING VALVE HANDLE	2
3	R-2407	OPERATING HANDLE BRACKET (NOT SHOWN)	1
4	849FSO-04-06	1/4" MALE JIC TO 3/8" MALE O-RING BOSS 90°	2
5	844FS-04-04	1/4" MALE JIC TO 1/4" MALE JIC TEE	2
6	HU04-04NJ	1/4" FEMALE JIC STRAIGHT COUPLER	12
7	HFS2-04	HOSE 12" LONG	2
8	HFS2-04	HOSE 20" LONG	2
9	HFS2-04	HOSE 33" LONG	2
10	-	1/4" UNC GR. 8 BOLT X 2.25" LONG (NOT SHOWN)	4
11	-	1/4" SAE WASHER (NOT SHOWN)	8
12	-	1/4" UNC GR. 3 NYLOCK NUT (NOT SHOWN)	4
13	R-32231	FITTING, 1/4" X 1/4" JIC SWIVEL 90°	N/A
14	-	HYDRAULIC HOSE TO FIT (SUPPLIED BY INSTALLER)	N/A
15	R-32230	FITTING, 1/4 MALE JIC X 1/2" MALE O-RING	N/A

REV	DESCRIPTION OF CHANGES	DATE	BY	APPRVD	ECN #	APPROVED	CHECKED	DRAWN
A	REVISION A RELEASED	11/22/04	LE	JMP				
B	UPDATED BORDER	07/18/21	SMM					

G & B SPECIALTIES INC.
MANUFACTURER OF QUALITY RAILROAD PRODUCTS
BERWICK, PENNSYLVANIA (570) 752-5901, FAX (570) 752-6397

DESIGN - ENGINEERING - MANUFACTURING
R450 HYDRAULIC KIT FOR PTO APPLICATIONS

FOR COMMENTS AND TO OBTAIN THIS DRAWING IN ANOTHER LANGUAGE OR TO REQUEST A QUOTE, PLEASE CONTACT US AT THE ABOVE ADDRESS OR BY PHONE. THIS DRAWING IS THE PROPERTY OF G&B SPECIALTIES INC. AND IS NOT TO BE REPRODUCED OR TRANSMITTED IN ANY FORM OR BY ANY MEANS, ELECTRONIC OR MECHANICAL, INCLUDING PHOTOCOPYING, RECORDING, OR BY ANY INFORMATION STORAGE AND RETRIEVAL SYSTEM, WITHOUT THE WRITTEN PERMISSION OF G&B SPECIALTIES INC.

SHEET/DRAWING NUMBER: 1 K-H45VRF005 DATE DRAWN: 11/22/04 PART NUMBER: K-H45VRF005 REVISION: B

OPERATION/SERVICE SAFETY PRECAUTIONS

If any operating, service or parts problems are encountered, please call G&B Specialties, Inc. for technical assistance.



- Failure to heed to any of the following warnings could result in severe bodily injury and/or equipment damage.
- Read and understand this manual completely before attempting operation of the railgear equipped vehicle.
- Operating instructions provided below only address the Rafna railgear equipment. Applicable railway company procedures and policies must be adhered to.
- Railway Company rules governing rail travel must be observed at all times.
- Before performing any work under the vehicle or railgear, ensure the engine is turned off and the parking brake is set.
- Ensure all body parts and loose clothing are clear of any moving parts of the railgear. Be aware of all pinch points.
- Note that if the railgear is part way retracted or extended, opening the manifold directional valve manual over-rides may cause the railgear to drop suddenly causing personal injury. Ensure all body parts are clear of the railgear if it should suddenly drop.
- When operating the railgear using the emergency hand pump, ensure that the correct manual valve over-ride is open for the desired railgear (front or rear) and desired direction of operation (raise or lower).
- Do not use the emergency hand pump to raise and lower the railgear on a routine basis. If the hydraulic pump or manifold should fail, have it repaired as soon as possible.
- If the emergency hand pump has been used to raise or lower the railgear, ensure the manifold directional valve manual over-rides are in the closed and locked position before starting road or rail travel.
- Ensure the hydraulic pump has been de-energized before starting road or rail travel.

OPERATION OF HYDRAULIC KIT (PTO)

With the hydraulic kit installed on this vehicle, it may be operated as normal.

Never operate the vehicle if the Gross Vehicle Weight Rating (GVWR), Gross Axle Weight Rating Front or Rear (GAWR), or the wheel or tire load ratings are exceeded.

Refer to the Railgear Kit Operation, Service and Parts manual for information on the mechanical operation, service and parts of the railgear.

Location and Operation of the Railgear Hydraulic System Controls:

1. The PTO must be engaged following the manufacturer's instructions. The railgear should not move until the operating valve is actuated.
2. Each railgear is equipped with an operating valve. The direction of motion (up or down) of the railgear is selected by actuating the operating valve handle. The railgear should move only in the selected direction.
3. To stop the movement of the railgear, bring the handle on the respective railgear operating valve to the center position.
4. Disengage the PTO following the manufacturer's instructions.

SERVICE OF HYDRAULIC KIT

The hydraulic kit must be serviced regularly to avoid damage to the equipment. Table 1 provides the Recommended Service Schedule and Table 2 provides Standard Fastener Torque Values.

The recommended oil for the railgear hydraulic system is **DEXRON III** or equivalent. In extremely cold weather areas/seasons, **Tellus S4 VX32** or equivalent may be used.

Table 1: Recommended Service Schedule

Service Required	Initial 100 km (62 Miles) of road and/or rail use	Daily	Weekly	Monthly
Inspect hydraulic kit fasteners (re-torque if required)		✓	✓	✓
Inspect all hydraulic fittings and hoses for leaks and wear		✓	✓	✓
Check oil in hydraulic reservoir (fill with railgear raised if req'd)				✓
Check emergency hand pump and manifold over-ride operation				✓

Table 2: Standard Fastener Torque Values

Fastener Size	Fastener Torque Value (ft-lbs) Dry
1" UNC Gr. 8 Fasteners	250
3/4" UNC Gr. 8 Fasteners	175
5/8" UNC Gr. 8 Fasteners	150
1/2" UNC Gr. 8 Fasteners	100
3/8" UNC Gr. 8 Fasteners	40
1/4" UNC Gr. 8 Fasteners	12

HYDRAULIC SYSTEM RELIEF VALVE SETTING

The following procedure details how to adjust the railgear pressure relief valve settings. One relief valve is located on each operating valve and there may be one or more additional relief valves in the railgear hydraulic system. An adjustment of the relief valve settings should be carried out at installation and/or if ever there appears to be inadequate hydraulic pressure to operate the railgear.

1. Locate the hydraulic hose that connects the front railgear operating valve to the railgear hydraulic system pressure line. Release the pressure in the railgear hydraulic system and disconnect this hose from the front railgear operating valve.
2. Install a combination test gauge (up to 3000 PSI) and shutoff valve between the disconnected hydraulic hose and the front operating valve. The pressure gauge will indicate the relief valve setting, while the shutoff valve will enable a false load to be put on the hydraulic pump. Ensure that the shutoff valve is installed between the test gauge and front operating valve.
3. Engage the PTO.
4. Close the shutoff valve to enable the railgear hydraulic system relief valve to start releasing pressure. The pressure reading on the test gauge should indicate 2000 PSI. If this reading is incorrect, adjust the railgear hydraulic system relief valve accordingly.
5. Once the correct pressure on the railgear hydraulic system relief valve is obtained, open the shutoff valve.
6. Proceed to adjust each operating valve relief valve setting as follows:
 - a) Have an assistant watch the test gauge pressure reading while adjusting the relief valve settings.
 - b) Ensure the shutoff valve has been completely opened.
 - c) With the railgear fully raised in road position, select “UP” on the operating valve. Hold in this position until the hydraulic oil passes over the relief valve and a reading is taken on the test gauge.
 - d) The pressure should be 1800 PSI on the front and rear operating valves. Adjust the relief valve setting accordingly.
 - e) Proceed to adjust the second operating valve relief valve setting.
7. Release the pressure in the railgear hydraulic system and remove the test gauge and shutoff valve.
8. Reconnect and tighten all hydraulic hoses.

THIS PAGE INTENTIONALLY LEFT BLANK

7.0 HYDRAULIC FRONT & REAR BRAKE KITS

INSTALLATION SAFETY PRECAUTIONS

If any installation problems are encountered, please call G&B Specialties, Inc. for technical assistance before continuing with the installation process.



- Failure to heed to any of the following warnings could result in severe bodily injury and/or equipment damage.
- Read and understand this manual completely before attempting installation of the equipment.
- Installation instructions provided below only address the RAFNA railgear equipment. Applicable railway company procedures and policies must be adhered to.
- Before performing any work under the vehicle or railgear, ensure the engine is turned off and the parking brake is set.
- Beware of all pinch points on the railgear and keep all parts of the body clear.
- When routing hydraulic hoses, ensure that the hoses do not contact any sharp edges or hot surfaces.
- All wire connections should be soldered and heat shrink sealed to prevent future corrosion-related problems.
- All wires must be covered with protective cable loom.
- Always disconnect the vehicle's battery when welding on the vehicle or railgear in order to protect the vehicle's electrical system.
- Do not use regular brake fluid in the hydraulic brake system, as it will damage the hydraulic brake pump and the brake cylinders.

INSTALLATION OF FRONT HYDRAULIC BRAKE KIT
Table 1: Front Hydraulic Brake Parts List (K-B45VXXR4697)

Part Number	Description	Quantity
R-4570D	Hydraulic Brake, Driver's Side	1
R-4570P	Hydraulic Brake, Passenger's Side	1
CO-106	Dash Switch	1
R-1577	5A In-Line Fuse	1
R-1577-1	Fuse, 5AMP	1
R-5670	Hydraulic Brake Pump	1
R-4574A	Hydraulic Brake Pump Bracket	1
R-5692	Electric Brake Control	1
CO-130H	"Railgear Brake Pump" Decal	1
H-990KIT-002	1/4" Male JIC to 1/4" Male JIC Tee	1
	Hose 24" Long	1
	Hose 38" Long	1
	Hose 51" Long	1
R-990KIT-025	1/4" UNC Gr. 8 Bolt x 3/4" Long	3
	1/4" SAE Washer	3
	1/4" Lock Washer	3
MISC.	4 & 14 Gauge Wire, Terminals, Wire Loom, etc.	As Req'd

1. Ensure that the rail wheels have been installed on the front railgear prior to installation of the Front Hydraulic Brake Kit.
2. Align the hydraulic brakes with the ends of the front railgear axle so that the 1/2" mounting holes in the brake housings align with the mounting holes in the axle as shown. Ensure that the brake housings are on the correct sides of the railgear axle. The brake shoe linkage of each brake housing should be toward the front of the vehicle.
3. Fasten each brake housing to the front railgear axle using four 1/2" x 1 3/4" bolts, eight 1/2" washers and four 1/2" nuts as shown (hardware included with brake assemblies). Torque the 1/2" fasteners to 100 ft-lbs dry. Do not over torque.
4. Remove the solenoid from the hydraulic brake pump by removing the strap that holds the solenoid to the motor housing. Re-install the solenoid in a convenient location under the hood close to the vehicle battery. Ensure that the solenoid body is properly grounded.
5. Fasten the hydraulic brake pump to the hydraulic brake pump bracket using three 1/4" x 3/4" long bolts, three 1/4" lock washers and three 1/4" washers. Torque the 1/4" fasteners to 12 ft-lbs dry. Do not over torque.
6. Align the hydraulic brake pump and bracket on the left-hand side of the railgear cross channel or in another suitable location. Ensure that the hydraulic hoses will be long enough to reach the pump. Clean and remove any paint from the area. Weld the hydraulic brake pump bracket to the railgear cross channel using a 1/4" fillet weld, both sides.

7. Position the electric brake control under the hood on or close to the vehicle firewall. Fasten the electric brake control to the vehicle using installer-supplied self-tapping screws.
8. Choose a suitable location on the vehicle dash and install the dash switch.
9. Affix the “Railgear Brake Pump” decal in a suitable location adjacent to the dash switch.
10. Using suitable 14 gauge wire, cable loom, connectors, solder and heat shrink tubing:
 - a. Lengthen as required, terminate and connect one of the red wires from the brake pump valve to reach to terminal 2 on the electric brake control.
 - b. Lengthen as required, terminate and connect the other red wire from the brake pump valve to a suitable ground location.
 - c. Terminate and connect a black wire from the power terminal on the brake pump solenoid to one end of the in-line fuse.
 - d. Terminate and connect another length of black wire from the other end of the in-line fuse through the firewall to the power terminal on the dash switch.
 - e. Terminate and connect a wire from the dash switch ground terminal to a suitable ground location on the vehicle.
 - f. Terminate and connect a wire from the load terminal on the dash switch to terminal 3 on the electric brake control.
 - g. Terminate and connect a wire from the switching terminal on the brake pump solenoid to terminal 6 on the electric brake control.
 - h. Terminate and connect a wire from terminal 7 on the electric brake control to a suitable ground location.
 - i. Terminate and connect a wire to terminal 1 on the electric brake control and splice it into the load wire from the vehicle service brake light switch behind the brake pedal.
11. Using suitable 4 gauge wire, cable loom, connectors, solder and heat shrink tubing:
 - a. Terminate and connect one wire from the vehicle’s battery to the power terminal on the brake pump solenoid.
 - b. Terminate and connect another wire from the load terminal on the brake pump solenoid to the power terminal on the brake pump motor.
 - c. Apply a small amount of silicon sealant to the pump motor and solenoid terminals to protect them from shorting out or rusting.
 - d. Ensure the brake pump motor base is properly grounded to the vehicle chassis by connecting a wire from the brake pump motor base to a suitable ground location on the vehicle. The railgear may not be properly grounded due to paint on the mounting plates and tar on the frame.
12. Connect the 51” long hydraulic hose to the 90° hydraulic fitting on the pump.
13. Connect the 1/4” Male JIC to 1/4” Male JIC tee fitting to the loose end of the 51” long hose.
14. Connect the 24” long hydraulic hose to the left-hand side of the tee fitting using the 1/4” female JIC coupler on the hose.
15. Connect the 38” long hydraulic hose to the right-hand side of the tee fitting using the 1/4” female JIC coupler on the hose.

16. Connect the loose end of the 24” long hydraulic hose to the left-hand side brake actuator.
17. Connect the loose end of the 38” long hydraulic hose to the right-hand side brake actuator.
18. Ensure that none of the hoses contact any sharp edges or hot surfaces. Secure all hoses leaving enough slack for the railgear to function.
19. Ensure that all wires and terminals are soldered, heat shrink sealed, enclosed in protective cable loom and secured with tie-wraps.
20. Ensure that any holes in the firewall are sealed and protected with a grommet.
21. Fill the hydraulic brake system and bleed the air out:
 - a. Fill the hydraulic brake pump tank with **DEXRON III** (or equivalent) hydraulic fluid.
 - b. Turn on the dash switch. Depress and hold the vehicle brake pedal. The hydraulic brake pump should start.
 - c. Open the air bleed valve on each brake cylinder to allow air to escape.
 - d. Close the air bleed valve on each brake cylinder.
 - e. Release the brake pedal.
 - f. Re-fill the hydraulic brake pump tank with hydraulic fluid.
 - g. Repeat the above steps until only oil and no more air comes out of the air bleed valve.
 - h. Fill the hydraulic brake pump tank to the fill line.
22. Paint any parts that were welded.
23. Follow the “Hydraulic Brake Relief Valve Setting” procedure detailed in the “Operation, Service and Parts” section of this Manual.
24. Follow the “Brake Shoe to Rail Wheel Clearance Adjustment” procedure detailed in the “Operation, Service and Parts” section of this Manual.
25. Test the operation of the hydraulic brakes as per the “Operation, Service and Parts” section of Manual.

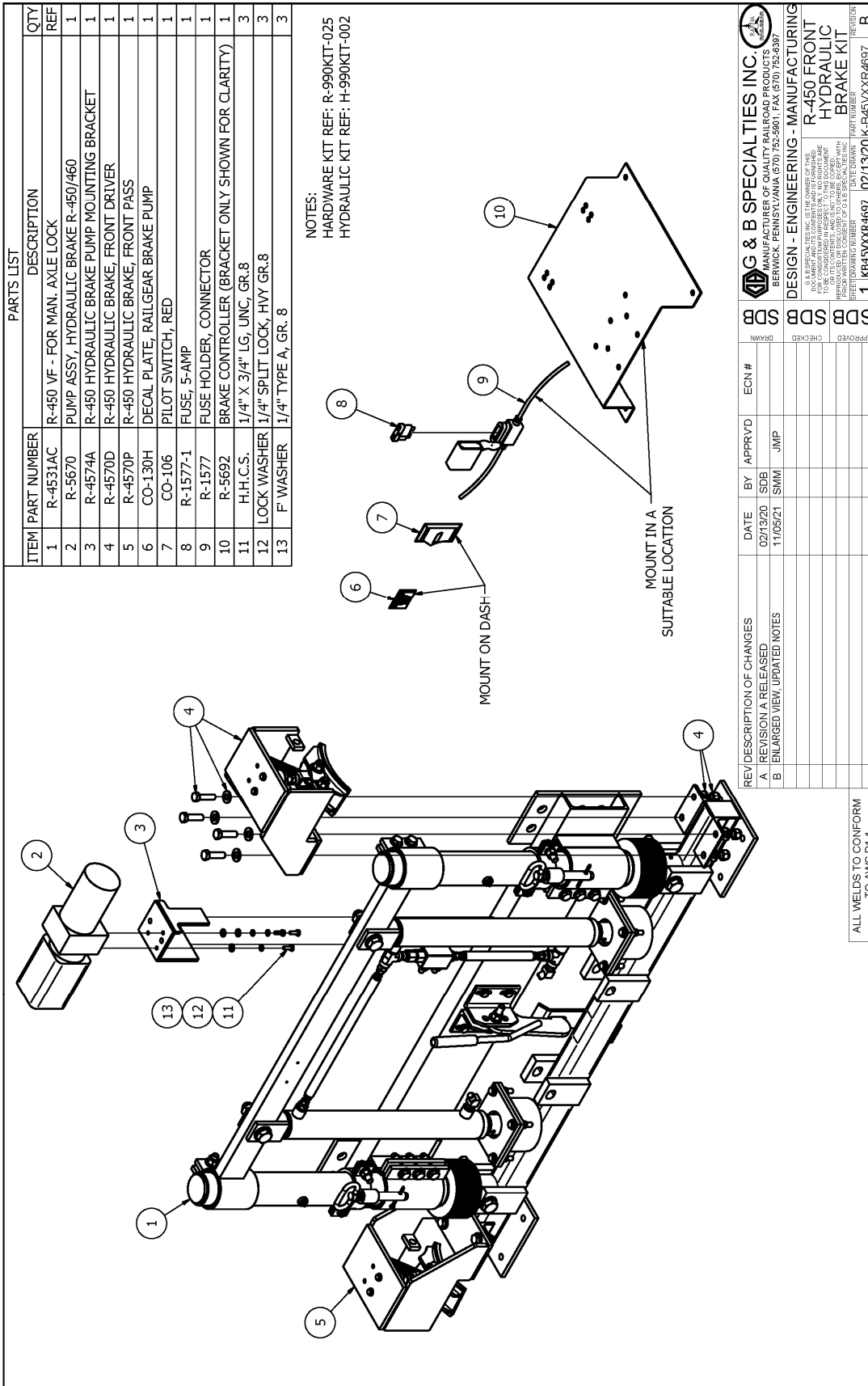

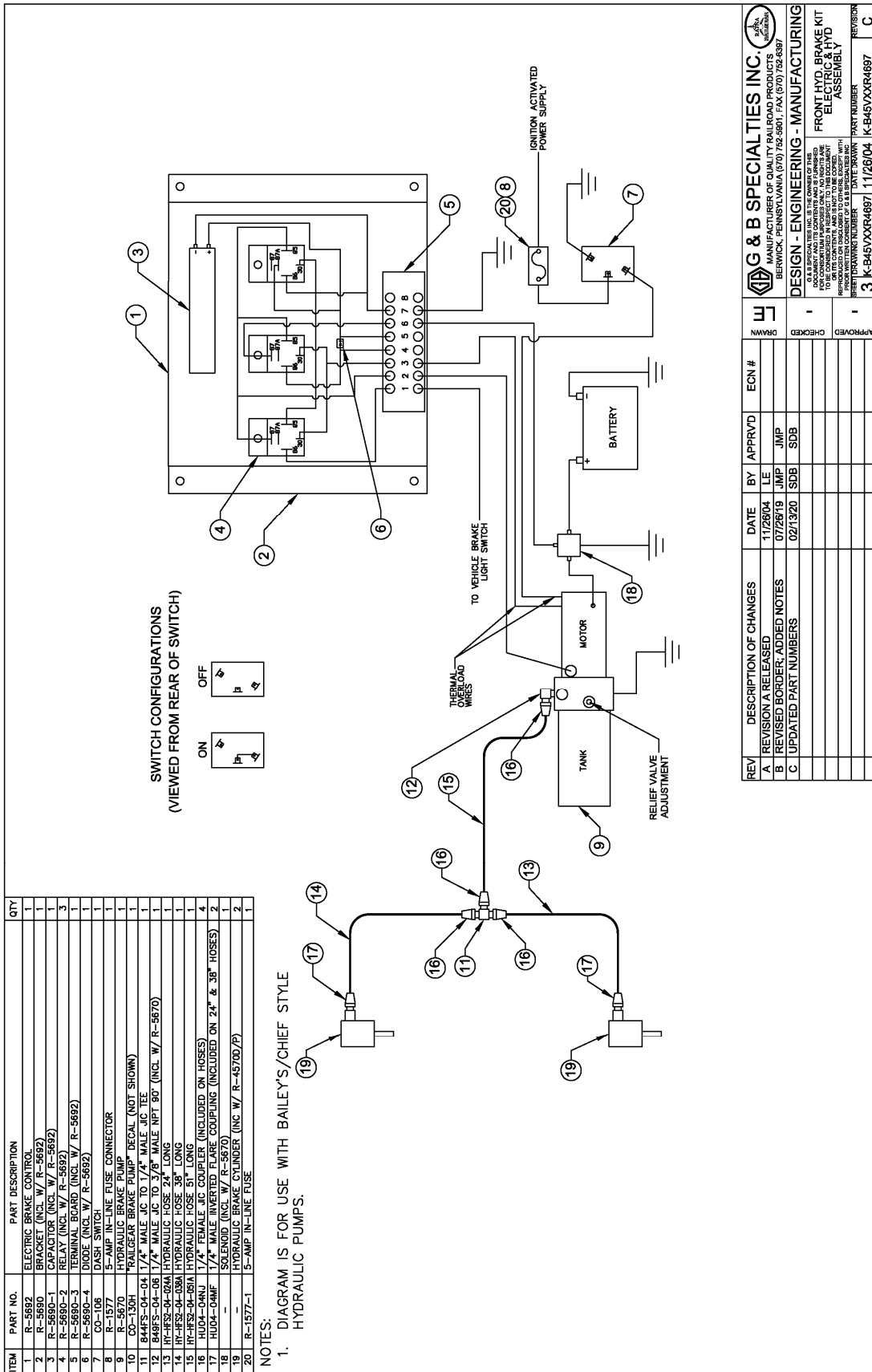

INSTALLATION OF REAR HYDRAULIC BRAKE KIT (OPTIONAL)

The following procedure details the installation of the Rear Hydraulic Brake Kit on the rear railgear. The hardware required for this installation is listed in Table 1.

Table 2: Part breakdown for K-B45XRFR4899

Part Number	Description	Quantity
R-4897D	Hydraulic Brake Assembly, Drivers Side	1
R-4897P	Hydraulic Brake Assembly, Passengers Side	1
H-990KIT-010	Reducer, 3/8 Male ORB x 1/4 Female ORB	1
	TEE, 1/4 Male JIC x 1/4 Male ORB	1
	TEE, 1/4" Male JIC to 1/4" Male JIC	1
	Hose 33" Long	1
	Hose 85" Long	1
	Hose 360" Long	1
R-990KIT-457 (2X)	1/2" UNC Gr. 8 Bolt x 2.25" Long	6
	1/2" Gr. 8 Washer	12
	1/2" UNC Gr. 8 Nylock Nut	6

1. Install the rear brake assemblies as shown. You must remove the standard rail sweep assemblies, and most of the standard wheel attachment hardware; they will not be reused, and new hardware is provided with this kit. Do not reuse Nylon Locking Nuts.
2. You must properly align the wheels after the brakes are installed (see appropriate R-450 Rotating Rear Installation, Operation, and Service manual, for your railgear order.)
3. Ensure that the brake pump has been installed per the front brake installation manual (MIO-B45VXXR4697).
4. Remove the 90° fitting installed on the hydraulic brake pump and replace it with the 3/8" Male ORB x 1/4" Female ORB adapter onto the pump.
5. Install the 1/4" Male JIC x 1/4" Male ORB onto the adapter.
6. Connect the loose end of the 32" hose for the front brakes to one side of the TEE.
7. Connect the loose end of the 360" hose for the rear brakes to the other side of the TEE.
8. Route the 360" hose to the rear railgear as required and connect the 1/4" Male JIC TEE fitting to the loose end of the 360" long hose.
9. For the driver side, connect one end of the 33" long hydraulic hose to the driver side brake cylinder and the other end the TEE attached to the loose end of 360" hose.
10. For the passenger side, connect one end of the 85" long hydraulic hose to the passenger side brake cylinder and the other end the TEE attached to the loose end of 360" hose.
11. Ensure that none of the hoses contact any sharp edges or hot surfaces. Secure all hoses leaving enough slack for the railgear to function.

12. Fill the hydraulic brake system and bleed the air out:
 - a. Fill the hydraulic brake pump tank with **DEXRON III** (or equivalent) hydraulic fluid.
 - b. Turn on the dash switch. Depress and hold the vehicle brake pedal. The hydraulic brake pump should start.
 - c. Open the air bleed valve on each brake cylinder to allow air to escape.
 - d. Close the air bleed valve on each brake cylinder.
 - e. Release the brake pedal.
 - f. Re-fill the hydraulic brake pump tank with hydraulic fluid.
 - g. Repeat the above steps until only oil and no more air comes out of the air bleed valve.
 - h. Fill the hydraulic brake pump tank to the fill line.
13. Follow the Hydraulic Brake Relief Valve Setting procedure detailed in the “Operation, Service and Parts” section of this manual.
14. Follow the Brake Shoe to Rail Wheel Clearance Adjustment procedure detailed in the “Operation, Service and Parts” section of this manual.
15. Test the operation of the hydraulic brakes as per the “Operation, Service and Parts” section of this manual.

PARTS LIST			
ITEM	PART NUMBER	DESCRIPTION	QTY
1	-	R-450 ROTATING REAR	REF
2	R-4897D	R-450 REAR BRAKE ASSY, DRIVER	1
3	R-4897P	R-450 REAR BRAKE ASSY, PASSENGER	1
4	H.H.C.S.	1/2" X 2 1/4" LG. UNC, GR.8	6
5	F WASHER	1/2" TYPE A, GR. 8	12
6	NYLOCK NUT	1/2" UNC, GR.8 STD NYLOCK	6
7	H-990KIT-010	REAR BRAKE HYDRAULIC KIT (NOT SHOWN)	1

NOTES:

- HARDWARE KIT REF: R-990KIT-457 (QTY. 2)
- REMOVE RAIL SWEEPS TO INSTALL REAR BRAKES
- REPLACE WHEEL HARDWARE TO ACCOMMODATE BRAKES
- THIS HARDWARE NOT REMOVED
- RUBBER SWEEP FACES REAR OF VEHICLE

REVISIONS:

REV	DESCRIPTION OF CHANGES	DATE	BY	APPRVD	ECN #
A	REVISION A RELEASED	02/19/20	SDB		

APPROVED: SDB (checked), SDB (checked), SDB (checked), SDB (checked)

DATE DRAWN: 02/19/20
PART NUMBER: R-450 REAR BRAKE INSTALLATION
FIGURE NUMBER: 1 KB45XFR4899

G&B SPECIALTIES INC.
MANUFACTURER OF QUALITY RAILROAD PRODUCTS
BERWICK, PENNSYLVANIA (570) 752-5901 FAX (570) 752-6397
DESIGN - ENGINEERING - MANUFACTURING

AS A SPECIALTY ITEM, THE NUMBER OF THIS DRAWING IS LIMITED. IF YOU REQUIRE THIS DRAWING FOR CONSULTATION PURPOSES ONLY, NO RIGHTS ARE GRANTED TO YOU. THIS DRAWING IS THE PROPERTY OF G&B SPECIALTIES INC. AND IS NOT TO BE COPIED, REPRODUCED, OR TRANSMITTED IN ANY FORM OR BY ANY MEANS, WITHOUT THE WRITTEN CONSENT OF G&B SPECIALTIES INC.

ALL WELDS TO CONFORM TO AWS D1.1

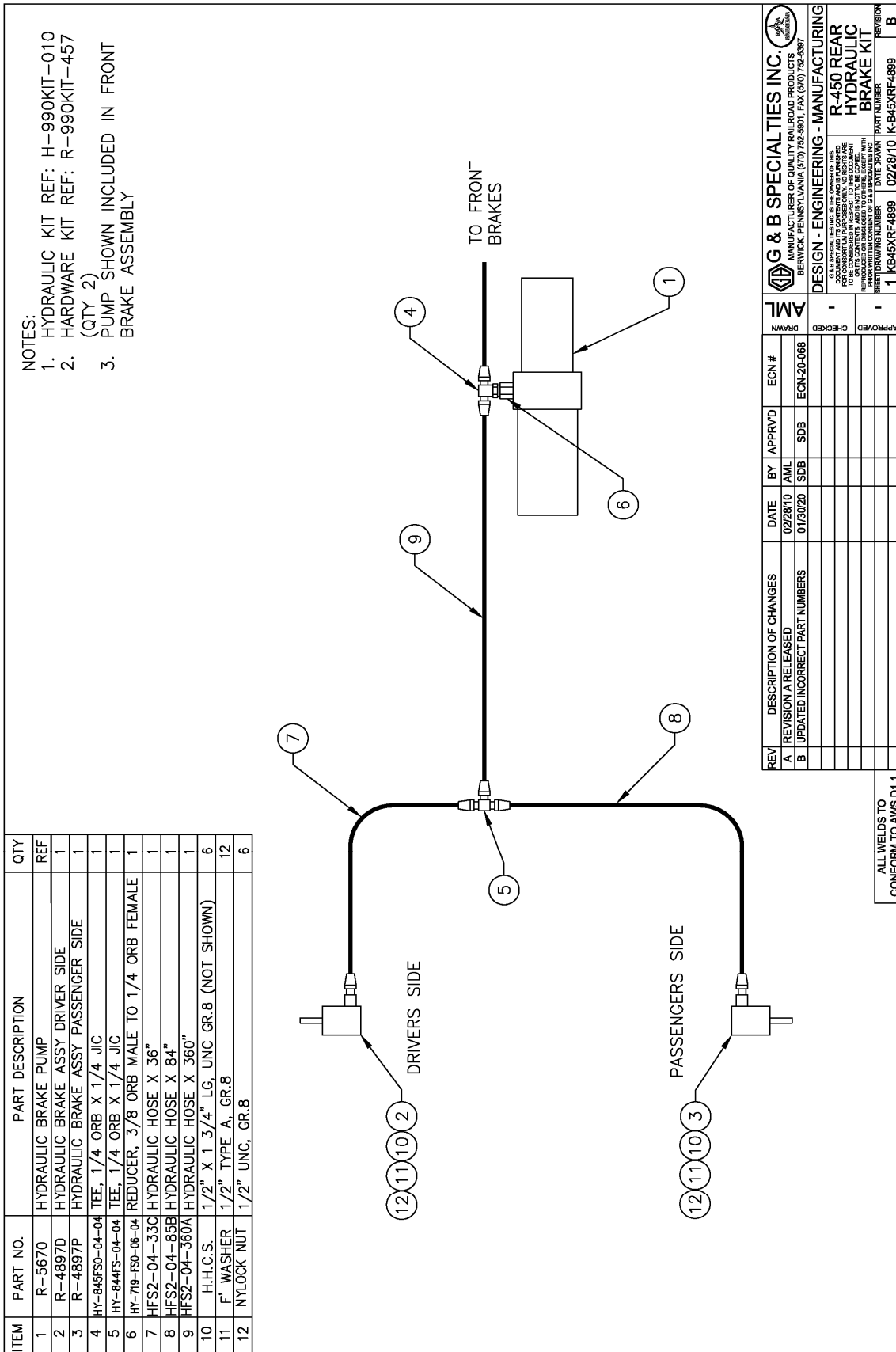

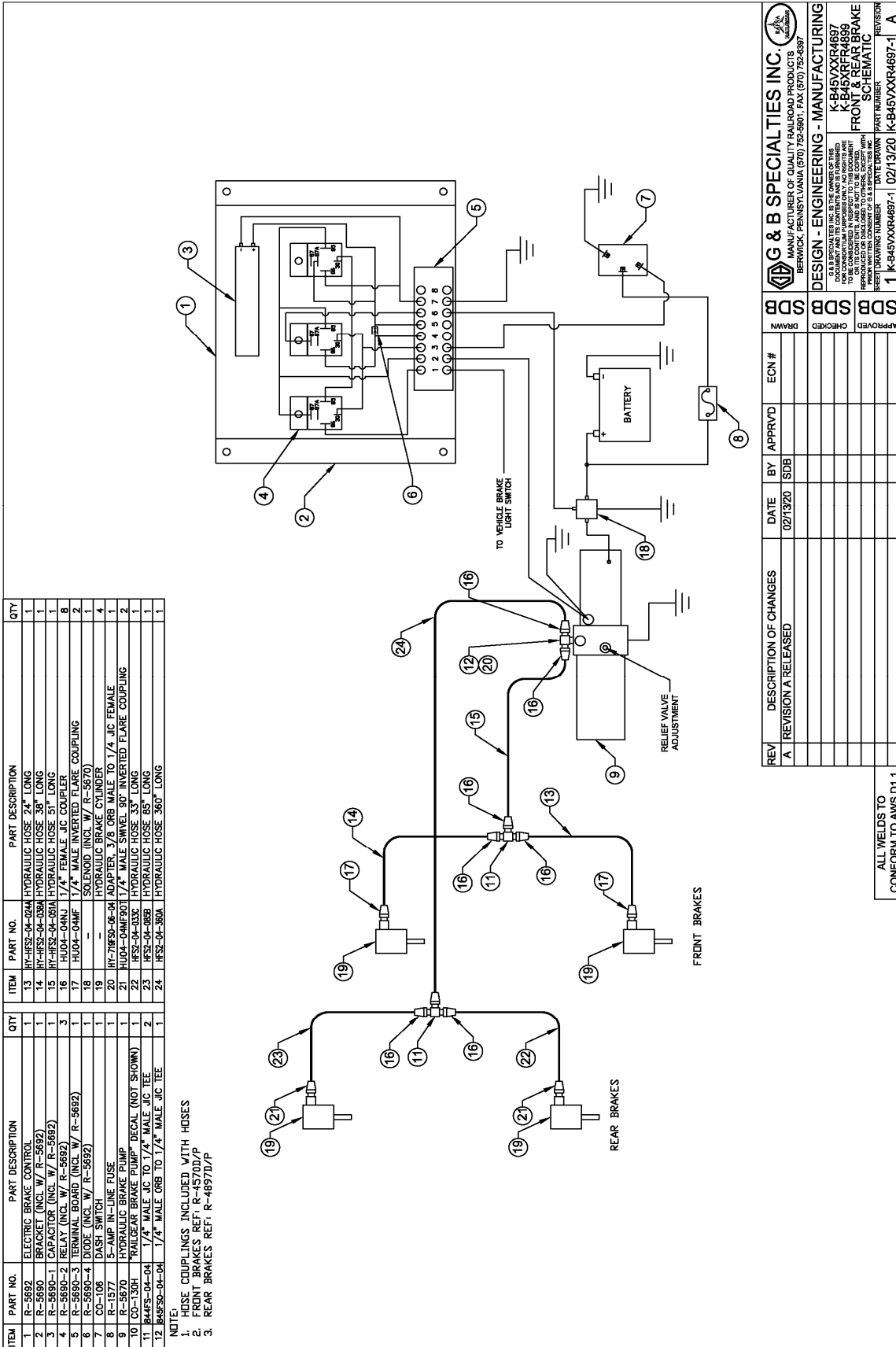

OPERATION SAFETY PRECAUTIONS

If any operation problems are encountered, please call G&B Specialties, Inc. for technical assistance before continuing with the installation process.



- Failure to heed to any of the following warnings could result in severe bodily injury and/or equipment damage.
- Read and understand this manual completely before attempting operation of the equipment.
- Operation instructions provided below only address the RAFNA railgear equipment. Applicable railway company procedures and policies must be adhered to.
- Before performing any work under the vehicle or railgear, ensure the engine is turned off and the parking brake is set.
- Beware of all pinch points on the railgear and keep all parts of the body clear.
- When routing hydraulic hoses, ensure that the hoses do not contact any sharp edges or hot surfaces.
- All wire connections should be soldered and heat shrink sealed to prevent future corrosion-related problems.
- All wires must be covered with protective cable loom.
- Always disconnect the vehicle's battery when welding on the vehicle or railgear in order to protect the vehicle's electrical system.
- Do not use regular brake fluid in the hydraulic brake system, as it will damage the hydraulic brake pump and the brake cylinders.

OPERATION OF HYDRAULIC BRAKE KIT

With the brake kit installed on this vehicle, it may be operated as normal. It should be noted, even when using the brake kit, stopping distances will be longer than on road. The hydraulic brake pump must be turned “Off” during road travel and “On” during rail travel. The hydraulic brake kit provides additional braking power when on rail. Braking distance on rail is much greater than when on road and will be adversely affected by inclement weather.

Never operate the vehicle if the Gross Vehicle Weight Rating (GVWR), Gross Axle Weight Rating Front or Rear (GAWR), or the wheel or tire load ratings are exceeded.

A dash switch is provided to turn off the power to the hydraulic brake pump, which prevents the railgear brakes from functioning during road travel. When traveling on rail, with the dash switch in the “On” position, the railgear hydraulic brakes act together with the vehicle’s brakes to provide added braking power through the rail wheels.

To Operate The Vehicle On Rail:

1. Turn the “Railgear Brake Pump” dash switch to the “On” position.
2. Proceed with rail travel. The railgear hydraulic brakes will function with the vehicle brakes when the vehicle brake pedal is depressed.

To Operate The Vehicle On Road:

3. Turn the “Railgear Brake Pump” dash switch to the “Off” position.
4. Proceed with road travel. The railgear hydraulic brakes will remain in-active.

SERVICE OF HYDRAULIC BRAKE KIT

The brake kit must be serviced regularly to avoid damage to the equipment. Table 1 below provides the Recommended Service Schedule and Table 2 provides Standard Fastener Torque Values.

Do not torque the 1/2" fasteners that pass through the brake shoe linkage. These fasteners must remain slightly loose to allow the hydraulic brakes to function freely. Table 2 provides all other Standard Fastener Torque Values.

Table 1: Recommended Service Schedule

Service Required	Initial 100 km (62 Miles) of road and/or rail use	Monthly	6 Months	Yearly
Inspect hydraulic brake kit fasteners (re-torque if required)	✓		✓	✓
Inspect all hydraulic fittings and hoses for leaks and wear	✓		✓	✓
Check oil in hydraulic reservoir (fill if required)	✓	✓		✓
Check / adjust brake shoe to rail wheel clearance (see procedure)	✓		✓	✓

Table 2: Standard Fastener Torque Values

Fastener Size	Fastener Torque Value (ft-lbs) Dry
1" UNC Gr. 8 Fasteners	250
3/4" UNC Gr. 8 Fasteners	175
5/8" UNC Gr. 8 Fasteners	150
1/2" UNC Gr. 8 Fasteners	100
7/16" UNC Gr. 8 Fasteners	65
3/8" UNC Gr. 8 Fasteners	40
1/4" UNC Gr. 8 Fasteners	12

BRAKE SHOE TO RAIL WHEEL CLEARANCE ADJUSTMENT

Caution:

The clearance between the brake shoe and the rail wheel must be correctly adjusted to prevent brake drag and to ensure proper braking ability. Check and adjust the brake shoe to rail wheel clearance as follows:

1. With the hydraulic brake dash switch turned “Off” and the railgear hydraulic brakes in the retracted position, visually inspect the railgear hydraulic brake components for excessive damage and/or wear and measure the brake shoe to rail wheel clearance.

Acceptable Brake Shoe To Rail Wheel Clearance

1/8” - 1/4”

2. If the brake shoe to rail wheel clearance is not within specifications, adjust as follows:
 - a. Loosen the jam nut above the clevis on the clevis push rod.
 - b. Turn the clevis push rod to adjust the clevis up to increase the clearance or down to decrease the clearance.
 - c. When moving the clevis down on the clevis push rod, do not move the clevis down beyond the point at which the inside bottom face of the clevis is flush with the end of the push rod. Replace the brake shoe and re-adjust.
 - d. Tighten the jam nut above the clevis on the clevis push rod.
3. Re-check the brake shoe to rail wheel clearance and re-adjust as necessary.

HYDRAULIC BRAKE RELIEF VALVE SETTING

The hydraulic brake pump is equipped with one relief valve located on the hydraulic pump body. This relief valve protects the entire hydraulic brake system from over pressurization. The relief valve will require adjustment at installation and if ever there appears to be inadequate hydraulic pressure to operate the hydraulic brakes or if the rail wheels are found to skid when the brakes are applied.

1. Disconnect the hydraulic hose from the pump.
2. Install a hydraulic pressure gauge (up to 3000 PSI) between the disconnected hydraulic hose and the pump port. The pressure gauge will indicate the relief valve setting when the pump is loaded.
3. Turn the “Railgear Brake Pump” dash switch to the “On” position and depress the vehicle brake pedal so that activating the brakes creates a load on the pump. The pressure reading on the pressure gauge should climb to 700 PSI.
4. If the pressure is not correct, release the brake pedal and adjust the relief valve on the pump accordingly. Loosen the lock nut and turn the setscrew in to increase the pressure or out to decrease the pressure. Re-check the pressure.
5. Once the correct pressure on the pump relief valve is obtained, ensure that the lock nut on the relief valve is tightened. Release the pressure in the system and remove the pressure gauge. Re-connect the hydraulic hose.
6. Ensure that the hydraulic hoses are connected properly and that the hydraulic brakes are functioning properly.

PARTS OF HYDRAULIC BRAKE KIT

PARTS LIST			
ITEM	PART NUMBER	DESCRIPTION	QTY
1	R-4561	BRAKE HOUSING, R-450, FRONT	1
2	R-4557	BRAKE SHOE LINKAGE	1
3	R-5603	HYDRAULIC BRAKE CYLINDER	1
4	R-5604	SPRING, EXTENSION	1
5	R-5602	HYDRAULIC BRAKE PUSH ROD	1
6	JAM NUT	1/2" UNF, GR.8 JAM HEX	1
7	R-5601	CLEVIS ASSY	1
8	R-4554	BRAKE SHOE ASSY, 10" WHEEL	1
9	H.H.C.S.	1/4" X 1 1/2" LG, UNC, GR.8	2
10	H.H.C.S.	1/2" X 4 1/2" LG, UNC, GR.8	1
11	H.H.C.S.	1/2" X 3 1/2" LG, UNC, GR.8	1
12	H.H.C.S.	1/2" X 1 3/4" LG, UNC, GR.8	4
13	F WASHER	1/4" TYPE A, GR. 8	2
14	F WASHER	1/2" TYPE A, GR. 8	12
15	NYLOCK NUT	1/4" UNC, GR.8 STD NYLOCK	2
16	NYLOCK NUT	1/2" UNC, GR.8 STD NYLOCK	6

NOTES:

- HARDWARE KIT REF: R-990KIT-026
- APPROX. WEIGHT: 23.3 LBS
- SPRING SHOULD BE IN CENTER OF CLEVIS
- DO NOT TORQUE BRAKE SHOE HARDWARE, BRAKE SHOE MUST REMAIN LOOSE
- IF NECESSARY, ADD WASHERS TO SHIM BREAK SHOE TO ALIGN WITH WHEEL CYLINDER COMES WITH A PLUG, BUT IT MAY NEED TO BE MOVED DURING INSTALLATION
- PLUG BRAKE CYLINDER ON SIDE AWAY FROM VEHICLE
- CONNECT HOSE TO BRAKE CYLINDER ON SIDE TOWARDS VEHICLE

NOTE 4: [Diagram showing the brake shoe linkage assembly]

NOTE 3: [Diagram showing the brake shoe linkage assembly]

NOTE 5: [Diagram showing the brake shoe linkage assembly]

NOTE 6, 7, 8: [Diagram showing the brake shoe linkage assembly]

ALL WELDS TO CONFORM TO AWS D1.1

REV	DESCRIPTION OF CHANGES	DATE	BY	APPRVD	ECN #
A	REVISION A RELEASED	07/21/84	M.P.		
B	ADD ITEM 14, MOD DWG BOM	10/12/86	S.A		
C	CHANGE PIN AND DWG#	06/07/89	R.H		
D	GENERAL UPDATE	03/27/01	V.Z		
E	CHANGED POSITION OF ITEM 5	ADDED SHOP NOTES	07/01/11	V.Z	
F	REVISED ITEM 12	02/13/03	MEER		
G	MODIFY ITEMS 1 & 5	02/18/03	V.Z		
H	UPDATE ADD ITEM 16	09/04/03	R.H		
J	REDEW IN INVENTOR	02/13/20	SDB		ECN-26-070

G & B SPECIALTIES INC.
MANUFACTURER OF QUALITY LOGGING PRODUCTS
BERWICK, PENNSYLVANIA (570) 752-5901, FAX (570) 752-6387
DESIGN - ENGINEERING - MANUFACTURING
R-450 HYDRAULIC BRAKE, DRIVER, FRONT
PART NUMBER: 02/13/20/R-4570D

PARTS LIST			
ITEM	PART NUMBER	DESCRIPTION	QTY
1	R-4561	BRAKE HOUSING, R-450, FRONT	1
2	R-4557	BRAKE SHOE LINKAGE	1
3	R-5603	HYDRAULIC BRAKE CYLINDER	1
4	R-5604	SPRING, EXTENSION	1
5	R-5602	HYDRAULIC BRAKE PUSH ROD	1
6	JAM NUT	1/2" UNF, GR.8 JAM HEX	1
7	R-5601	CLEVIS ASSY	1
8	R-4554	BRAKE SHOE ASSY, 10" WHEEL	1
9	H.H.C.S.	1/4" X 1 1/2" LG, UNC, GR.8	2
10	H.H.C.S.	1/2" X 4 1/2" LG, UNC, GR.8	1
11	H.H.C.S.	1/2" X 3 1/2" LG, UNC, GR.8	1
12	H.H.C.S.	1/2" X 1 3/4" LG, UNC, GR.8	4
13	F WASHER	1/4" TYPE A, GR. 8	2
14	F WASHER	1/2" TYPE A, GR. 8	12
15	NYLOCK NUT	1/4" UNC, GR.8 STD NYLOCK	2
16	NYLOCK NUT	1/2" UNC, GR.8 STD NYLOCK	6

NOTES:

- HARDWARE KIT REF: R-990KIT-026
- APPROX. WEIGHT: 23.3 LBS
- SPRING SHOULD BE IN CENTER OF CLEVIS
- DO NOT TORQUE BRAKE SHOE HARDWARE, BRAKE SHOE MUST REMAIN LOOSE
- IF NECESSARY, ADD WASHERS TO SHIM BREAK SHOE TO ALIGN WITH WHEEL CYLINDER COMES WITH A PLUG, BUT IT MAY NEED TO BE MOVED DURING INSTALLATION
- PLUG BRAKE CYLINDER ON SIDE AWAY FROM VEHICLE
- CONNECT HOSE TO BRAKE CYLINDER ON SIDE TOWARDS VEHICLE

ALL WELDS TO CONFORM TO AWS D1.1

REV	DESCRIPTION OF CHANGES	DATE	BY	APPRVD	ECN #
0	REVISION A RELEASED	07/21/04	M.P.		
1	ADD ITEM 14, MOD DIMS BOM	10/12/08	S.A.		
2	CHANGE PIN AND DIMS#	06/07/09	R.H.		
3	GENERAL UPDATE	03/27/01	V.Z.		
4	CHANGED POSITION OF ITEM 5	ADDED SHOP NOTED 05/07/01	V.Z.		
5	REMOVED ITEM 10	02/13/03	MEF		
6	MODIFY ITEMS 1 & 5	GENERAL REVISION	02/18/03	V.Z.	
7	UPDATE ADD ITEM 16		03/04/03	R.H.	
8	REBUILD IN INVENTOR		02/13/20	SDB	ECN-20-071

SDB	SDB	SDB	SDB	SDB	SDB
DRAWN	CHECKED	APPROVED	DATE DESIGNED	PART NUMBER	REVISION
			02/13/20	R-450 HYDRAULIC BRAKE, PASS, FRONT	J
				1 R4570P	02/13/20 R-4570P

PARTS LIST		PARTS LIST	
ITEM	PART NUMBER	DESCRIPTION	QTY
1	R-4895D	BRAKE HOUSING, DRIVER SIDE	1
2	R-4896	BRAKE LEVER	1
3	R-4554	BRAKE SHOE ASSY, 10" WHEEL	1
4	R-5603	HYDRAULIC BRAKE CYLINDER	1
5	R-5602	HYDRAULIC BRAKE PUSH ROD	1
6	R-5604A	EXTENSION SPRING (R-5604 CUT IN HALF)	2
7	R-2411	RUBBER SWEEP	1
8	R-5561	SWEEPER PLATE	1
9	R-5590-6	1" CHAIN LINK BENT UP AT 30°	2
10	H.H.C.S.	1/4" X 1 1/2" LG, UNC, GR.8	4
11	H.H.C.S.	1/2" X 3 1/4" LG, UNC, GR.8	2
12	F' WASHER	1/4" TYPE A, GR. 8	6
13	F' WASHER	1/2" TYPE A, GR. 8	10
14	JAM NUT	1/2" UNF, GR.8 JAM HEX	2
15	NYLOCK NUT	1/4" UNC, GR.8 STD NYLOCK	4
16	NYLOCK NUT	1/2" UNC, GR.8 STD NYLOCK	2

NOTES:

- CYLINDER MUST BE PLUGGED AS DEPICTED
- PLUG COMES INSTALLED IN CYLINDER, BUT MAY NEED TO BE MOVED FROM IT'S ORIGINAL LOCATION
- LINK MUST BE BENT AS DEPICTED BELOW BEFORE INSTALLING UNDER BOLT HEAD
- 6 WASHERS MUST BE USED TO SPACE INSIDE OF BRAKE SHOE ON 1/2" BOLT
- APPROX. WEIGHT: 32.2 LBS
- HARDWARE KIT REF: R-990KIT-060

REV	DESCRIPTION OF CHANGES	DATE	BY	APPRVD	ECN #
A	REVISION A RELEASED	08/07/01	V.Z.		
B	ADD ITEMS #13 & #16, MODIFY #8	10/16/02	V.Z.		
C	MODIFY ITEM #6	07/20/03	V.Z.		
D	UPDATE BRAKE SHOE, HYDRAULIC CYLINDER	11/13/03	L.M.E.		
E	NOTE REMOVED	09/21/05	J.M.P.		
F	REVISED/REDISGN ITEM #1	04/13/05	A.V.I.L.		
G	ADDED HOLE FOR HOSE	09/04/15	S.W.M.I.		ECN-20-049
H	REDREW IN INVENTOR	07/28/20	S.D.B.		ECN-21-228
J	UPDATED TO SHOW HOSE CUTOUT	04/16/21	S.W.M.I.		

ALL WELDS TO CONFORM TO AWS D1.1

PARTS LIST			PARTS LIST				
ITEM	PART NUMBER	DESCRIPTION	QTY	ITEM	PART NUMBER	DESCRIPTION	QTY
1	R-4895P	BRAKE HOUSING, PASSENGER SIDE	1	9	R-5590-6	1" CHAIN LINK BENT UP AT 30°	2
2	R-4896	BRAKE LEVER	1	10	H.H.C.S.	1/4" X 1 1/2" LG, UNC, GR.8	4
3	R-4554	BRAKE SHOE ASSY, 10" WHEEL	1	11	H.H.C.S.	1/2" X 3 1/4" LG, UNC, GR.8	4
4	R-5603	HYDRAULIC BRAKE CYLINDER	1	12	F' WASHER	1/4" TYPE A, GR. 8	6
5	R-5602	HYDRAULIC BRAKE PUSH ROD	1	13	F' WASHER	1/2" TYPE A, GR. 8	10
6	R-5604A	EXTENSION SPRING (R-5604 CUT IN HALF)	2	14	JAM NUT	1/2" UNF, GR.8 JAM HEX	2
7	R-2411	RUBBER SWEEP	1	15	NYLOCK NUT	1/4" UNC, GR.8 STD NYLOCK	4
8	R-5561	SWEEPER PLATE	1	16	NYLOCK NUT	1/2" UNC, GR.8 STD NYLOCK	2

NOTES:

- CYLINDER MUST BE PLUGGED AS DEPICTED
- PLUG COMES INSTALLED IN CYLINDER, BUT MAY NEED TO BE MOVED FROM IT'S ORIGINAL LOCATION
- LINK MUST BE BENT AS DEPICTED BELOW BEFORE INSTALLING UNDER BOLT HEAD
- 6 WASHERS MUST BE USED TO SPACE INSIDE OF BRAKE SHOE ON 1/2" BOLT
- APPROX. WEIGHT: 32.2 LBS
- HARDWARE KIT REF: R-990KIT-060

R-5590-6 WITH BEND

NOTE 3

NOTE 4

NOTE 1

NOTE 2

NOTE 4

HOSE CUTOUT

30°

.28

REV	DESCRIPTION OF CHANGES	DATE	BY	APPRVD	ECN #
A	REVISION 1 RELEASED	09/21/05	JMP		
B	ADD ITEMS #13 & #16, MODIFY #6	10/16/02	V.Z.		
C	MODIFY ITEM #6	07/20/03	V.Z.		
D	UPDATE BRAKE SHOE, HYDRAULIC CYLINDER	11/13/03	LME		
E	DRAWING RELEASED	09/21/05	JMP		
F	REVISED/REDESIGN ITEM #1	04/13/05	AVIL		
G	ADDED HOLE FOR HOSE	09/04/15	SNM		
H	REVIEW IN INVENTOR	07/28/20	SDB		ECN-20-050
J	ADDED HOLE FOR HOSE	04/16/21	SDB		ECN-21-228
K	UPDATED TO SHOW HOSE CUTOUT		JMP		

ALL WELDS TO CONFORM TO AWS D1.1

G&B SPECIALTIES INC. MANUFACTURER OF QUALITY RAILROAD PRODUCTS. BERWICK, PENNSYLVANIA 17011-1701, PA. (570) 752-5901

DESIGN - ENGINEERING - MANUFACTURING

HYDRAULIC BRAKE PACKAGE

PASSENGER SIDE

1 R4897P 09/21/05 R-4897P K

PARTS LIST			
ITEM	PART NUMBER	DESCRIPTION	QTY
1	S-309600	MOTOR	1
2	S-309601	SOLENOID	1
3	S-309682	BODY VALVE BLOCK	1
4	S-309642	PUMP	1
5	S-309606	RELIEF	1
6	S-309683	CHECK VALVE (INTERNAL)	1
7	S-309643	2 WAY, 2 POSITION VALVE	1
8	S-309632	COIL	1
9	S-309608	TANK	1
10	S-309644	COUPLING	1
11	S-309645	SUCTION OIL PIPE	1
12	S-309646	FILTER	1
13	S-309612	MAGNET	1
14	S-309613	O-RING	1
15	S-309615	HEX FLANGE SCREW	4
16	S-309661	RESPIRATOR ASSEMBLY	1
17	S-309617	OIL RETURN PIPE	1
18	S-309647	HEX SOCKET BOLT ASSEMBLY	2
19	S-309620	IRON PLUG	1
20	S-309623	CABLE	1
21	S-309624	INSULATION COVER (RED)	2
22	S-309625	HOOP	1
23	S-309626	WHITE CABLE ASSEMBLY	1
24	S-309684	GROUND BOLT	1
25	S-309648	NUT	1

REVISION DESCRIPTION OF CHANGES	DATE	BY	APPRVD	ECN #	
A REVISION A RELEASED	03/19/20	SDB	SMM		
B UPDATED PART NUMBERS	07/14/20	SMM	SMM		

G & B SPECIALTIES INC. MANUFACTURER OF QUALITY RAILROAD PRODUCTS BERWICK, PENNSYLVANIA (570) 752-5901, FAX (570) 752-6397	DESIGN - ENGINEERING - MANUFACTURING	BAILEY R-5670
G & B SPECIALTIES INC. IS THE OWNER OF THIS DOCUMENT. IT IS TO BE USED ONLY FOR THE PURPOSES AND CONDITIONS SPECIFIED IN THE TITLE BLOCK. ANY REUSE OR MODIFICATION OF THIS DOCUMENT WITHOUT THE WRITTEN CONSENT OF G & B SPECIALTIES INC. IS PROHIBITED.		
SDB	SMM	SMM
APPROVED	CHECKED	DESIGNED
1	R5670	03/19/20/R-5670
		B

NOTES:
1. SEE SHEET 2 FOR HYDRAULIC SCHEMATIC
2. TO BE USED WITH BAILEY PUMPS ONLY

ALL WELDS TO CONFORM TO AWS D1.1

- NOTES:
 1. SEE SHEET ONE FOR PARTS LIST
 2. TO BE USED WITH BAILEY PUMPS ONLY

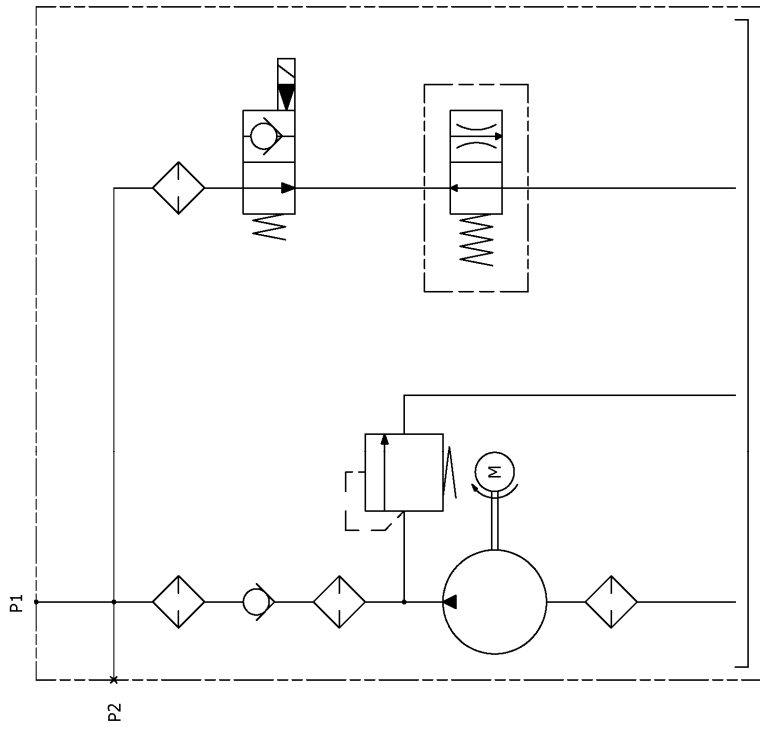

G & B SPECIALTIES INC.
 MANUFACTURER OF QUALITY RAILROAD PRODUCTS
 BERWICK, PENNSYLVANIA 17011-5901, FAX: (570) 752-6397

DESIGN - ENGINEERING - MANUFACTURING
 BAILEY R-5670
 HYDRAULIC PUMP
 PARTS BREAKDOWN
 REFERENCE PART NUMBER
 2 R5670 03/19/20 R-5670

REV/DESCRIPTION OF CHANGES	DATE	BY	APPRVD	ECN #
A REVISION/A RELEASED	03/19/20	SDB	SDB	
B UPDATED PART NUMBERS	07/14/20	SWM	SWM	

ALL WELDS TO CONFORM TO AWS D1.1

8.0 STEERING WHEEL LOCK

INSTALLATION SAFETY PRECAUTIONS

If any installation problems are encountered, please call G&B Specialties, Inc. for technical assistance before continuing with the installation process.



- Failure to heed to any of the following warnings could result in severe bodily injury and/or equipment damage.
- Read and understand this manual completely before attempting installation of the equipment.
- Installation instructions provided below only address the Rafna railgear equipment. Applicable railway company procedures and policies must be adhered to.
- Ensure the areas where the adhesive back strips will be affixed are clean, and free of dirt and grease. Do not touch these areas or the adhesive on the back of the strips.
- Wait a minimum of 24 hours for the adhesive strips to fully cure before using the steering wheel lock.
- Ensure that the steering wheel lock does not interfere with any vehicle devices including the air bags

INSTALLATION OF STEERING WHEEL LOCK
Table 1: Steering Wheel Lock Parts List (K-SXXXXX00450)

Part Number	Description	Qty
S-001050	Steering Wheel Lock	1
S-001040	Steering Wheel Lock Decal	1
R-21164	Speed Decal	1

1. Ensure the front wheels are pointing straight ahead and the steering wheel is centered before installation.
2. The steering wheel lock consists of one steering wheel lock patch with Rafna logo and three adhesive back strips.
3. Without removing the protective backing, position one adhesive back strip on top of the steering column cover and another on the steering wheel. The strips should be close enough together so that the patch will cover both when the steering wheel lock is engaged. Ensure that the adhesive back strips do not interfere with any devices, such as the hazard light button on the steering column cover or the air bag cover on the steering wheel. Modify the adhesive back strips as required to clear any obstructions. Mark their locations on the steering column cover and the steering wheel.
4. Without removing the protective backing, position the third adhesive back strip in a convenient location on the dash (so that it does not interfere with the view and/or operation of the vehicle). This adhesive back strip will serve as a holder when the steering wheel lock is disengaged. Mark the location.
5. Scuff the three areas previously marked with medium / fine sand paper. The areas should be free of dust, dirt, and any oily residue. Thoroughly clean the areas with denatured alcohol or a similar non-oil based degreaser that will not react with the plastic. Let dry.
6. Take care when placing the adhesive back strips; once they are applied, they should not be removed. Do not touch the adhesive with your fingers. Removing the adhesive back strips once installed or touching the adhesive may cause poor adhesion.
7. Peel off the protective backing from the adhesive back strips. Firmly press them into place as previously located. Do not disturb the adhesive back strips for 24 to 30 hours to allow the adhesive to fully cure.
8. Store the steering wheel lock patch on the adhesive back strip located on the dash.
9. Stick the steering wheel lock decal in a highly visible spot on the dashboard.
10. Stick the maximum speed decal in a highly visible spot, within clear sight of the operator, on the dashboard.

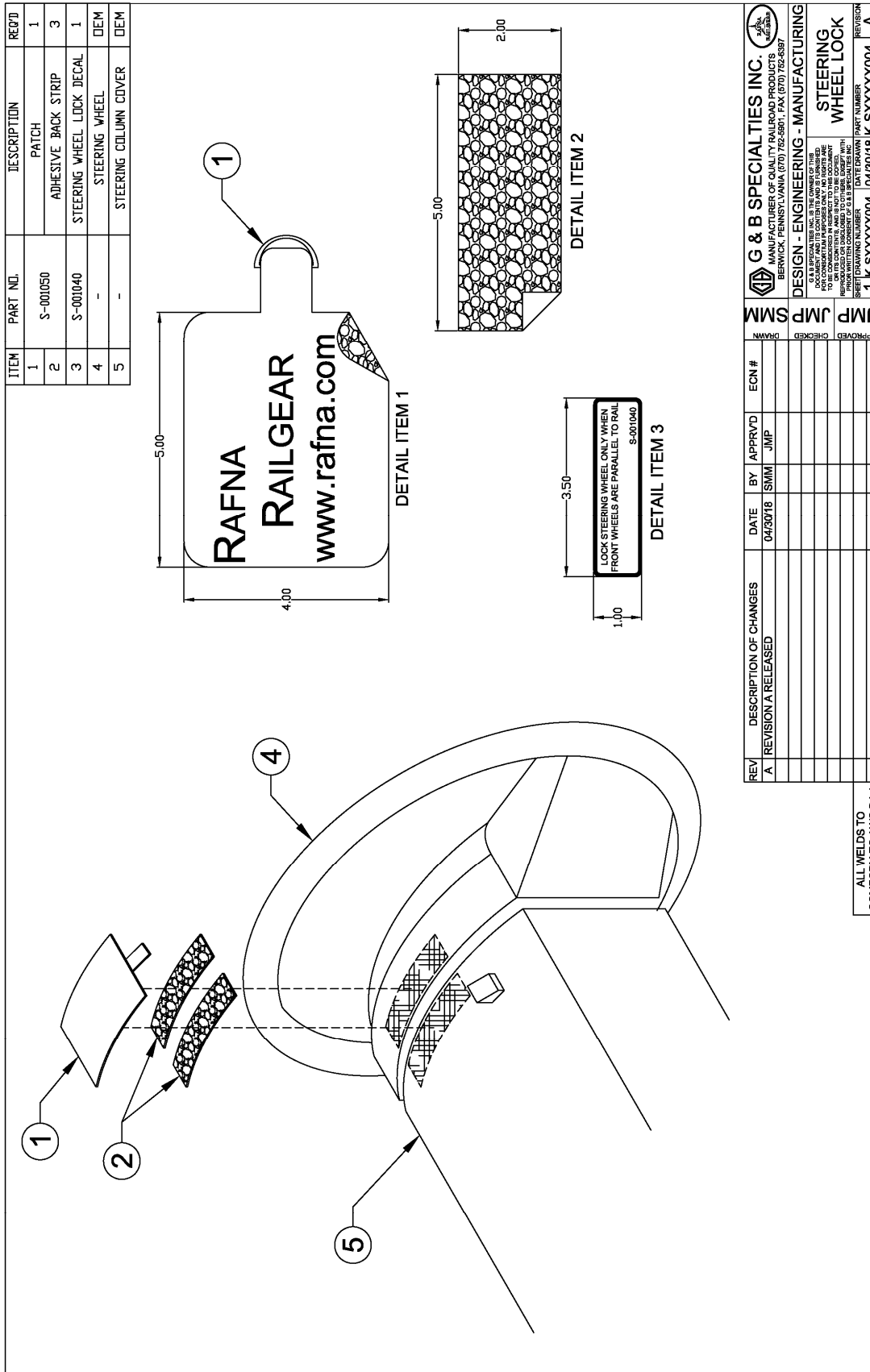

ITEM	PART NO.	DESCRIPTION	REQ'D
1	S-001050	PATCH	1
2	S-001050	ADHESIVE BACK STRIP	3
3	S-001040	STEERING WHEEL LOCK DECAL	1
4	-	STEERING WHEEL	DEM
5	-	STEERING COLUMN COVER	DEM

REV	DESCRIPTION OF CHANGES	DATE	BY	APPRVD	ECN #	APPROVED	CHECKED	DRAWN
A	REVISION A RELEASED	04/20/18	ISMM	JMP				

JMP	SMM	DATE	BY	APPRVD	ECN #	APPROVED	CHECKED	DRAWN

DESIGN - ENGINEERING - MANUFACTURING	STEERING WHEEL LOCK	REVISION
G & B SPECIALTIES INC. IS THE OWNER OF THIS MANUFACTURER OF QUALITY RAILROAD PRODUCTS BERWICK, PENNSYLVANIA (70) 752-5901, FAX (70) 752-6397		
FOR CONSULTATION PURPOSES ONLY AND NOT BE USED FOR CONSTRUCTION. ANY CHANGES TO BE MADE MUST BE APPROVED BY THE DESIGN ENGINEER AND MANUFACTURER WITH THE CONSENT OF G & B SPECIALTIES INC.		
SHEET DRAWING NUMBER	DATE	REVISION
1 K-SXXXXX004	04/30/18	K-SXXXXX004
		A

ALL WELDS TO CONFORM TO AWS D1.1

R-21164 THIS VEHICLE IS EQUIPPED WITH
A RAIL CONVERSION UNIT
RAFNA MODEL R-450
35 MPH / 56 KM/H
RECOMMENDED MAXIMUM SPEED ON RAIL
Railway company rules governing rail travel must be observed at all times.

OPERATION SAFETY PRECAUTIONS

If any operating, services or parts problems are encountered, please call G&B Specialties, Inc. for technical assistance.



- Failure to heed to any of the following warnings could result in severe bodily injury and/or equipment damage.
- Read and understand this manual completely before attempting operation of the railgear equipped vehicle.
- Operating instructions provided below only address the RAFNA railgear equipment. Applicable railway company procedures and policies must be adhered to.
- Railway company rules governing rail travel must be observed at all times.
- At level rail crossings, ensure that no other vehicles are approaching and flag the crossing to ensure safety. This vehicle will not operate crossing signals. Use caution when approaching and traversing level crossings.
- The steering wheel lock must be engaged at all times while on rail.

OPERATION OF STEERING WHEEL LOCK

The following procedure details the steering wheel lock operation.

1. Placing The Vehicle On The Track:

- Engage the steering wheel lock after both the front and rear railgear are fully deployed and prior to rail travel.
- Turn the steering wheel until the front tires point straight ahead.
- Position the patch portion of the steering wheel lock onto the adhesive back strips affixed to the steering wheel and steering column cover. Press firmly into place. When installed on the adhesive back strips the patch should restrict the steering wheel from turning.

2. Traveling On Rail:

- The steering wheel lock must be engaged at all times while on rail.

3. Removing The Vehicle From The Track:

- Disengage the steering wheel lock after both the front and rear Railgear are fully retracted in the road position and prior to road travel.
- Firmly grasp the steering wheel lock patch's d-ring and peel it off the adhesive back strips.
- Store the patch on the adhesive back strip which serves as the holder located on the dash.

SERVICE OF STEERING WHEEL LOCK

Take care when removing the Patch. Due to certain plasticizers in the steering wheel steering column cover and dash, along with the vehicle's operating environment, the adhesive back strips may peel off and be removed. If the adhesive back strips do peel off, replace the strips with new ones at the earliest convenience.

9.0 EMERGENCY HAND PUMP FOR PTO APPLICATIONS

INSTALLATION SAFETY PRECAUTIONS

If any installation problems are encountered, please call G&B Specialties, Inc. for technical assistance before continuing with the installation process.



- Failure to heed to any of the following warnings could result in severe bodily injury and/or equipment damage.
- Read and understand this manual completely before attempting installation of the equipment.
- Installation instructions provided below only address the Rafna railgear equipment. Applicable railway company procedures and policies must be adhered to.
- Before performing any work under the vehicle or railgear, ensure the engine is turned off and the parking brake is set.
- Beware of all pinch points on the railgear and keep all parts of the body clear.
- When routing hydraulic hoses, ensure that the hoses do not contact any sharp edges or hot surfaces.
- When routing electrical wires, ensure that the wires do not contact any sharp edges or hot surfaces.
- All wire connections are to be soldered and heat shrink sealed to prevent future corrosion related problems.
- All wires must be covered with protective cable loom.
- Always disconnect the vehicle's battery when welding on the vehicle or railgear in order to protect the vehicle's electrical system.

INSTALLATION OF EMERGENCY HAND PUMP

K-H46EMG001 - Emergency Hand Pump Kit - 1/4		
Part Number	Description	Qty
R-8594	Ball Valve	2
R-23200	4-Way cross connector, 1/4 JIC	4
R-23204	1/4 Quick Connect Plug	4
R-23202	1/4 Quick Connect Coupler	2
R-23206	1/4 Dust Cap	4
R-23208	1/4 Dust Plug	2
R-056	Emergency Hand Pump	1

K-H46EMG002 - Emergency Hand Pump Kit - 3/8		
Part Number	Description	Qty
R-8594	Ball Valve	2
R-23201	4-Way cross connector, 3/8 JIC	4
R-23205	3/8 Quick Connect Plug	4
R-23203	3/8 Quick Connect Coupler	2
R-23207	3/8 Dust Cap	4
R-23209	3/8 Dust Plug	2
R-056	Emergency Hand Pump	1

NEW INSTALLS:

1. The emergency hand pump quick connects and components must be installed in conjunction with the main hydraulic kit as ordered for the vehicle. Refer to the following hydraulic schematic for additional information.

EXISTING INSTALLS:

1. The emergency hand pump quick connects and components must be integrated into the existing hydraulics of the vehicle. Refer to the following hydraulic schematic for additional information.

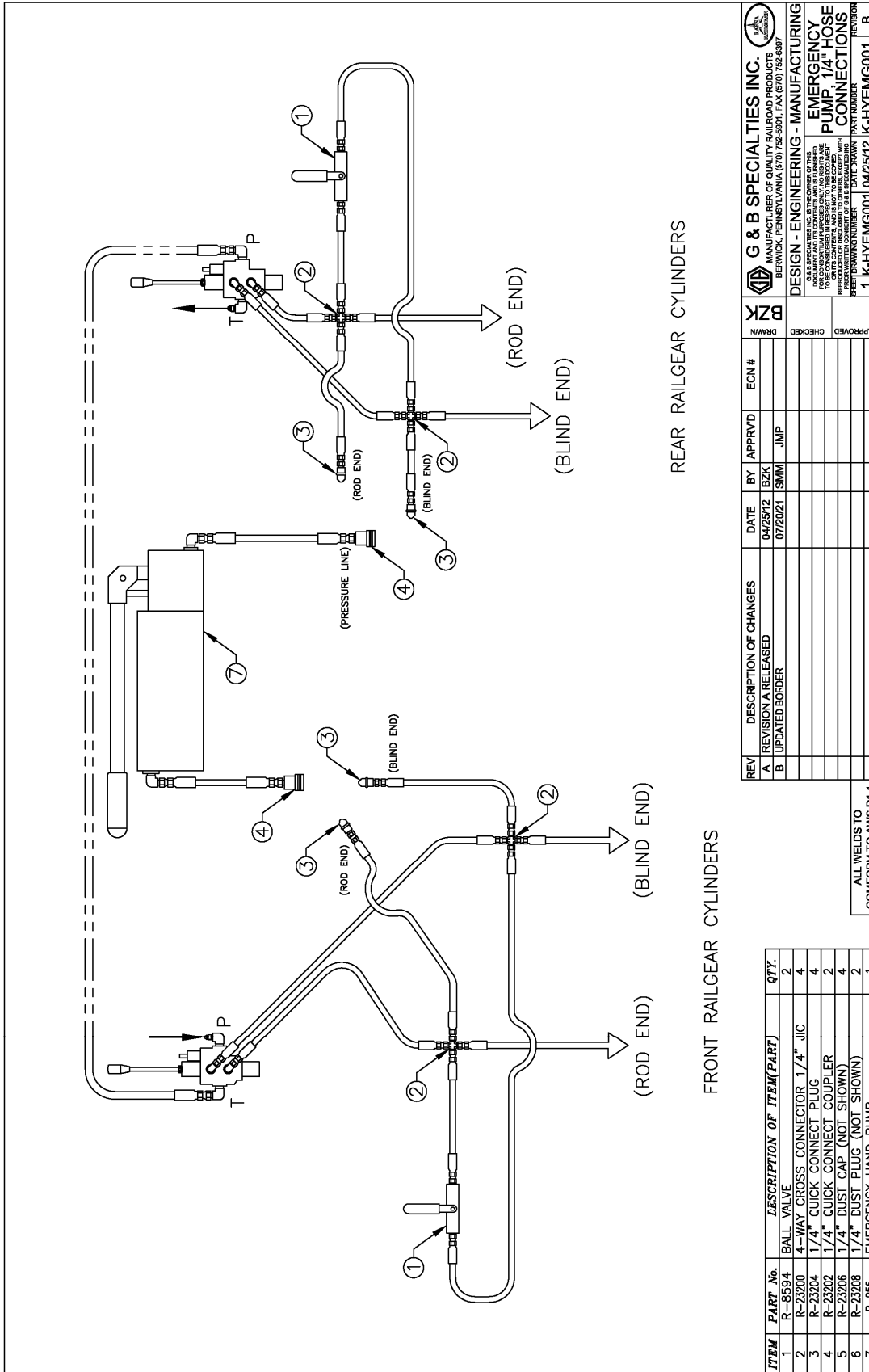

REAR RAILGEAR CYLINDERS

FRONT RAILGEAR CYLINDERS

ITEM	PART No.	DESCRIPTION OF ITEM(PART)	QTY.
1	R-8594	BALL VALVE	2
2	R-23200	4-WAY CROSS CONNECTOR 1/4" JIC	4
3	R-23204	1/4" QUICK CONNECT PLUG	4
4	R-23202	1/4" QUICK CONNECT COUPLER	2
5	R-23206	1/4" DUST CAP (NOT SHOWN)	4
6	R-23208	1/4" DUST PLUG (NOT SHOWN)	2
7	R-056	EMERGENCY HAND PUMP	1

REV	DESCRIPTION OF CHANGES	DATE	BY	APPRVD	ECN #
A	REVISION A RELEASED	04/25/12	BZK	JMP	
B	UPDATED BORDER	07/20/21	SMMI		

APPROVED	CHECKED	
BZK	BZK	

G & B SPECIALTIES INC.	MANUFACTURER OF QUALITY RAILROAD PRODUCTS
BERWICK, PENNSYLVANIA (970) 752-5801, FAX (970) 752-6397	
DESIGN - ENGINEERING - MANUFACTURING	EMERGENCY PUMP 1/4" HOSE CONNECTIONS
<small>G & B SPECIALTIES INC. IS THE OWNER OF THE MANUFACTURE OF QUALITY RAILROAD PRODUCTS FOR CONSTRUCTION PURPOSES ONLY. NO PARTS ARE TO BE USED IN ANY OTHER APPLICATIONS WITHOUT THE WRITTEN CONSENT OF G & B SPECIALTIES INC.</small>	
1 K-HYEMG001	04/25/12 K-HYEMG001 B

ALL WELDS TO CONFORM TO AWS D1.1

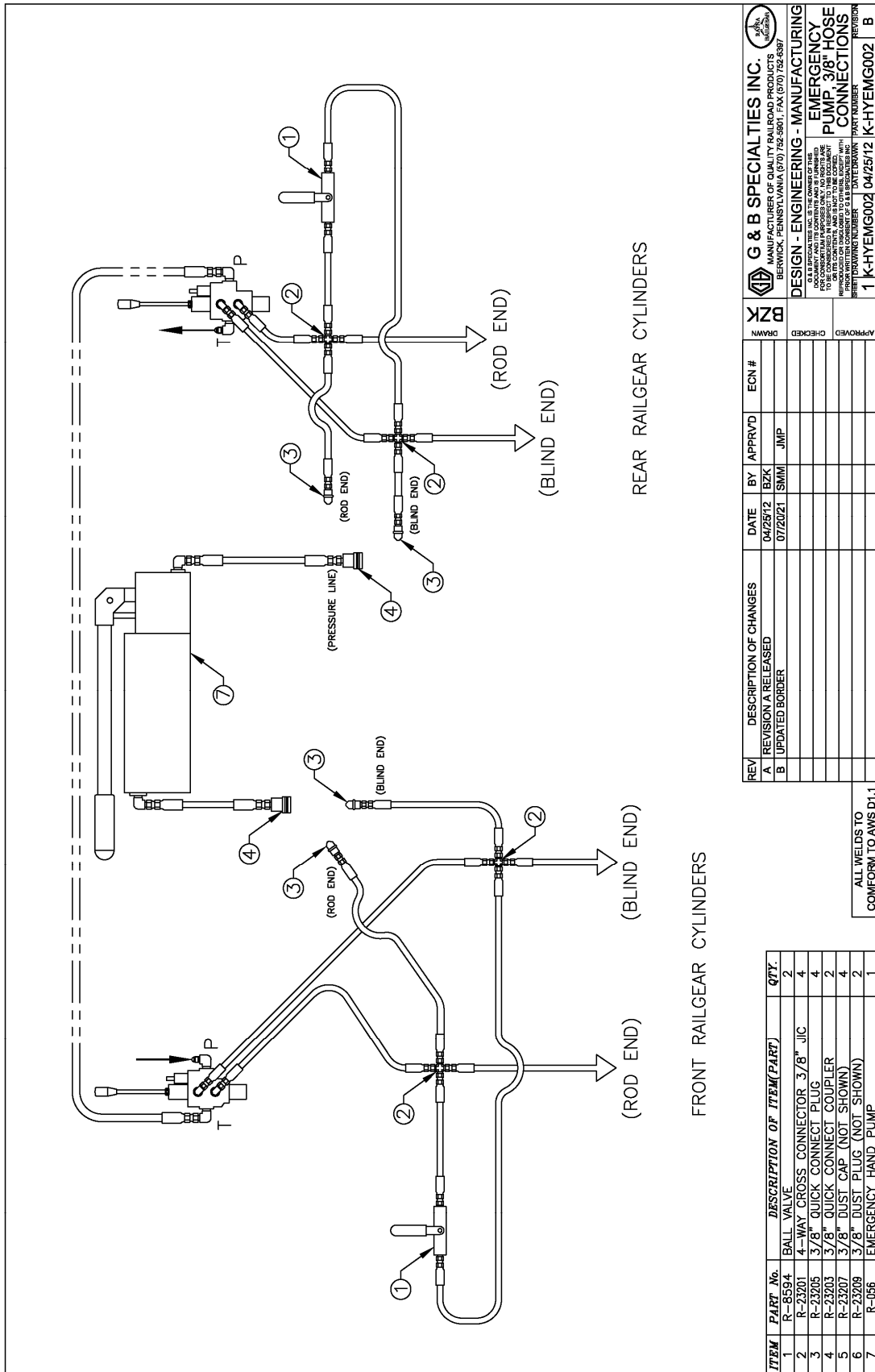

ITEM	PART No.	DESCRIPTION OF ITEM(PART)	QTY
1	R-8594	BALL VALVE	2
2	R-23701	4-WAY CROSS CONNECTOR 3/8" JIC	4
3	R-23705	3/8" QUICK CONNECT PLUG	4
4	R-23703	3/8" QUICK CONNECT COUPLER	2
5	R-23707	3/8" DUST CAP (NOT SHOWN)	4
6	R-23709	3/8" DUST PLUG (NOT SHOWN)	2
7	R-056	EMERGENCY HAND PUMP	1

REV	DESCRIPTION OF CHANGES	DATE	BY	APPRVD	ECN #
A	REVISION A RELEASED	04/25/12	BZK	JMP	
B	UPDATED BORDER	07/20/21	SMM		

APPROVED	CHECKED	DRAWN

DESIGN - ENGINEERING - MANUFACTURING	EMERGENCY PUMP, 3/8" HOSE CONNECTIONS
G & B SPECIALTIES INC. IS THE OWNER OF THIS MANUFACTURER OF QUALITY RAILROAD PRODUCTS BERWICK, PENNSYLVANIA (970) 752-5901, FAX (970) 752-6397	
FOR CONSULTATION PURPOSES ONLY, NO RIGHTS ARE GRANTED FOR REPRODUCTION OR DISTRIBUTION OF THIS DOCUMENT. ANY REPRODUCTION OF THIS DOCUMENT WITHOUT THE WRITTEN CONSENT OF G & B SPECIALTIES INC. IS STRICTLY PROHIBITED.	
1 K-HYEMG002 04/25/12 K-HYEMG002 B	

ALL WELDS TO CONFORM TO AWS D1.1

OPERATION SAFETY PRECAUTIONS

If any operating, service or parts problems are encountered, please call G&B Specialties, Inc. for technical assistance.



- Failure to heed to any of the following warnings could result in severe bodily injury and/or equipment damage.
- Read and understand this manual completely before attempting operation of the railgear equipped vehicle.
- Operating instructions provided below only address the Rafna railgear equipment. Applicable railway company procedures and policies must be adhered to.
- Railway company rules governing rail travel must be observed at all times.
- Before performing any work under the vehicle or railgear, ensure the engine is turned off and the parking brake is set.
- Ensure all body parts and loose clothing is clear of any moving parts of the railgear. Be aware of all pinch points.
- Ensure the hydraulic pump has been de-energized before starting road or rail travel.
- Never operate the vehicle if the Gross Vehicle Weight Rating (GVWR), Gross Axle Weight Rating Front or Rear (GAWR), or the wheel or tire load ratings are exceeded.

EMERGENCY HAND PUMP OPERATION

The emergency hand pump is designed to operate the railgear if the vehicle's PTO should fail. It can be used to raise and / or lower the railgear.



WARNING:

Do not use the emergency hand pump to raise and lower the railgear on a routine basis.

The following emergency hand pump operating procedures can be substituted into the normal operating procedures. The hand pump tank should be no more than 1/2 full. If the oil level is higher than this, it is possible for the tank to overflow.

To Raise Each Railgear Off The Track:

1. Position the hand pump on a solid railway tie near the railgear.
2. Locate the two hydraulic quick connects on the railgear. There is a ball valve between the two quick connects. Carefully open this ball valve. Note that if the railgear is partially off the track already, it may drop when the ball valve is opened. This will equalize the hydraulic pressure in the railgear hydraulic cylinder.
3. Locate the release valve on the hand pump. Open this valve to equalize the hydraulic pressure in the hand pump.
4. Remove the quick connect dust shields and connect the hand pump quick connects to the railgear quick connects. Ensure the hand pump pressure line is connected to the rod end of the hydraulic cylinder.
5. Close the ball valve between the quick connects on the railgear. Close the release valve on the hand pump.
6. Pump the hand pump to raise the railgear until the railgear locking pin clicks into place. Ensure that the lock pin is fully engaged.
7. Carefully open the ball valve between the quick connects on the railgear. Note that the railgear may drop if the lock pin is not engaged.
8. Carefully open the release valve on the hand pump. Note that the railgear may drop if the lock pin is not engaged.
9. Disconnect the hand pump quick connects and replace the dust shields on the quick connects.
10. Close the ball valve between the quick connects on the railgear. Close the release valve on the hand pump.

To Lower Each Railgear Onto The Track:

1. Position the hand pump on a solid railway tie near the railgear.
2. Locate the two hydraulic quick connects on the railgear. There is a ball valve between the two quick connects. Carefully open this ball valve. Note that the railgear may drop if the lock pin is not engaged. This will equalize the hydraulic pressure in the railgear hydraulic cylinder.
3. Locate the release valve on the hand pump. Open this valve to equalize the hydraulic pressure in the hand pump.
4. Remove the quick connect dust shields and connect the hand pump quick connects to the railgear quick connects. Ensure the hand pump pressure line is connected to the rod end of the hydraulic cylinder.
5. Close the ball valve between the quick connects on the railgear. Close the release valve on the hand pump.
6. Pump the hand pump to raise the railgear until the railgear locking pin can be disengaged. Disengage the lock pin.
7. Ensure that there is nothing beneath the railgear. Open the ball valve between the quick connects on the railgear. The railgear will drop to the rail position.
8. Disconnect and reconnect the quick connects so that the hand pump pressure line is connected to the blind end of the hydraulic cylinder. Close the ball valve between the quick connects on the railgear.
9. Pump the hand pump to lower the railgear until the hydraulic cylinder is fully extended.
10. Open the ball valve between the quick connects on the railgear. Open the release valve on the hand pump.
11. Disconnect the hand pump quick connects and replace the dust shields on the quick connects. Ensure that the ball valve between the quick connects on the railgear is closed and the release valve on the hand pump is closed.

THIS PAGE INTENTIONALLY LEFT BLANK

10.0 VERTICAL FRONT MANUAL LOCK KIT

INSTALLATION SAFETY PRECAUTIONS

If any installation problems are encountered, please call G&B Specialties, Inc. for technical assistance before continuing with the installation process.



- Failure to heed to any of the following warnings could result in severe bodily injury and/or equipment damage.
- Read and understand this manual completely before attempting installation of the equipment.
- Installation instructions provided below only address the RAFNA railgear equipment. Applicable railway company procedures and policies must be adhered to.
- Before performing any work under the vehicle or railgear, ensure the engine is turned off and the parking brake is set.
- Do not start the vehicle with the power steering hoses disconnected. Reconnect all hoses and secure the power steering cooler if the vehicle is started.
- Ensure all removed components are given to the vehicle owner after the installation of the railgear. These components must be re-installed if the railgear is removed from the vehicle.
- Always disconnect the vehicle's battery when welding on the vehicle or railgear in order to protect the vehicle's electrical system.
- Railway Company rules governing rail travel must be observed at all times.
- Never operate the vehicle if the Gross Vehicle Weight Rating (GVWR), Gross Axle Weight Rating Front or Rear (GAWR), or the wheel or tire load ratings are exceeded.

INSTALLATION OF FRONT RAILGEAR MANUAL LOCK KIT

The following procedure details the installation of the front railgear manual lock kit. The hardware required for this installation is listed in the table below.

Table 1: Front Railgear Manual Lock Installation Parts

Part Number	Description	Qty
R-10701	Hitch Pin	2
R-10702	Clamp Half	2
R-10706	Clamp Half with Holder	2
R-10707	Tether	2
R-10708	Split Ring	2
R-10709	Hairpin Clip	2
R-10900	Decal, "Pin Guide Tubes"	2
R-990KIT-418	3/8" UNC Gr. 8 Bolt x 1-1/4" Long	4
	3/8" Lock Washer, Split	4
	3/8" UNC Hex Nut	4

1. The front railgear manual lock cannot be installed until the railgear has been completely installed on the vehicle.
2. Deploy the front unit to the rail position by extending the cylinders to the maximum stroke. This gear is to stay in this position until installation is complete.
3. Locate the top of the inner guide by measuring from the center of the bolted connection at the axle up 26.875". This will be the top of the inner guide.
4. Measure up another 1.625" from the top of the inner guide or 28.5" from the center of the bolted connection. This dimension is a minimum distance the pin can be from the top of the inner guide. This will be the centerline of the placement of the clamps and hitch pin. Repeat for opposite side.
5. Clamp the two halves together using the 3/8" hardware supplied with the kit. Do not torque the hardware. The centerline of the clamps should be centered on the centerline marked in the previous step. The ears of the clamps should be parallel to the front of the vehicle. Repeat for opposite side.
6. Drill a 25/32" hole through the clamp using the hole predrilled as a guide. Drill each side separately to ensure it will line up properly. Repeat for opposite side.
7. Clean and deburr the area of any metal shavings.
8. Ensure the pin fits through the holes.
9. With the pin still in position, stitch weld the top and bottom of each clamp to the outer guide.
10. Remove pin and place in holder with hairpin clip, locking it in the holder.
11. Pass the tether through itself as shown, around the pin handle.

12. Install the split ring on the free end of the tether.
13. Install the hairpin clip onto the split ring. The pin, hairpin clip, and tether should be all tied together at this point.
14. Apply the decal to the front of the railgear, on each tube, approximately 2” above the clamps. The decal should be plainly visible when in standing in front of the gear, and when installing the lock pin.
15. Gear can now be raised to road position.



-WARNING-



If any components of the locking system become worn or damaged, components must be replaced with Rafna approved parts and unit put back to fully functioning condition. Any modifications/alterations to the railgear to circumvent this will void any warranty/support from Rafna on future issues. This includes, but is not limited to, drilling of the outer and inner guide tubes for a pinned/bolted connection lockup in the road or rail position. Failure to heed to this warning could result in severe bodily injury and/or equipment damage.

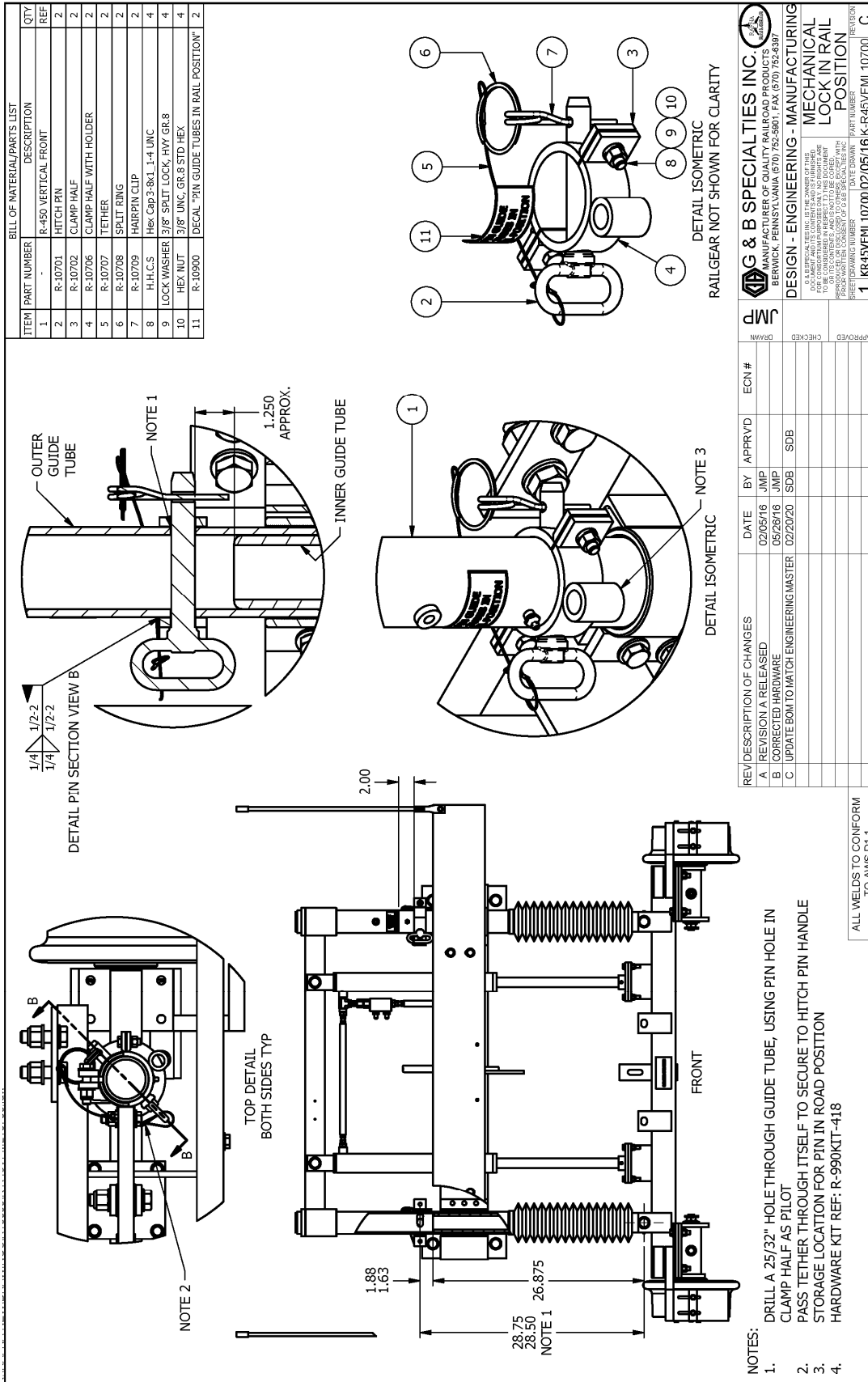

OPERATION SAFETY PRECAUTIONS

If any operating, service or parts problems are encountered, please call G&B Specialties, Inc. for technical assistance.



- Failure to heed to any of the following warnings could result in severe bodily injury and/or equipment damage.
- Read and understand this manual completely before attempting operation of the railgear equipped vehicle.
- Operating instructions provided below only address the Rafna railgear equipment. Applicable railway company procedures and policies must be adhered to.
- Railway company rules governing rail travel must be observed at all times.
- Before performing any work under the vehicle or railgear, ensure the engine is turned off and the parking brake is set.
- Never operate the vehicle if the Gross Vehicle Weight Rating (GVWR), Gross Axle Weight Rating Front or Rear (GAWR), or the wheel or tire load ratings are exceeded.

OPERATION OF FRONT RAILGEAR MANUAL LOCK KIT

With the front railgear manual lock kit installed on this vehicle, it may be operated as normal.

The front railgear manual lock should only be engaged for rail travel and must be disengaged for road travel. Never operate this vehicle on the road with the manual lock engaged.

Never operate the vehicle if the Gross Vehicle Weight Rating (GVWR), Gross Axle Weight Rating Front or Rear (GAWR), or the wheel or tire load ratings are exceeded.

To Engage Manual Lock:

1. Deploy the front railgear to the rail position.
2. Remove hairpin clip from hitch pin and remove hitch pin from holder.
3. Insert pin into the hole in the clamp and outer guide and engage hairpin clip once the hitch pin is fully through the outer guide.
4. Repeat for opposite side.

To Disengage Manual Lock:

1. Remove hairpin clip from hitch pin and remove from the clamp and outer guide.
2. Insert hitch pin into the clamp holder and engage hairpin clip for road travel storage.
3. Repeat for the opposite side.
4. Retract the front railgear to the road position.

SERVICE OF FRONT RAILGEAR MANUAL LOCK KIT

The front railgear manual lock kit must be serviced regularly to avoid damage to the equipment. Table 1 below provides the Recommended Service Schedule and Table 2 provides Standard Fastener Torque Values. DO NOT torque the 3/8" hardware.

Table 1: Recommended Service Schedule

Service Required	Daily	Weekly	Monthly
Inspect kit for wear on pin and outer guide		✓	✓

Table 2: Standard Fastener Torque Values

Fastener Size	Fastener Torque Value (ft-lbs) Dry
1" UNC Gr. 8 Fasteners	250
¾" UNC Gr. 8 Fasteners	175
5/8" UNC Gr. 8 Fasteners	150
½" UNC Gr. 8 Fasteners	100
3/8" UNC Gr. 8 Fasteners	40
¼" UNC Gr. 8 Fasteners	12

THIS PAGE INTENTIONALLY LEFT BLANK

11.0 RAILGEAR KITS/PARTS LISTS

G&B SPECIALTIES RAILGEAR				5-Mar-20
K-M45VXFF017 Front Mounting Kit				rev. D
Vehicle Application Chart				
Year	Make	Model #	Model	
2017-Present	Ford		F-450 All Models	
2017-Present	Ford		F-550 All Models	
Part Number	Description	# Req.	Remarks	Check
HR K-M45VXFF017 Front Mounting Kit				
R-33304D	Mounting Plate, Drivers Side	1		
R-33306P	Mounting Plate, Passengers Side	1		
R-33303D-A	Side Plate Assembly, Drivers Side	1		
R-33305P-A	Side Plate Assembly, Passengers Side	1		
R-33300	Frame Extension	2		
R-33309	Frame Extension Spacer	2		
R-11114A	Tie Bar Mntg Plate	1		
R-990KIT-107A	5/8" UNC GR.8 HHCS X 7" LONG	8		
	5/8" UNC GR.8 HHCS X 2" LONG	4		
	5/8" GR.8 NARROW TYPE A WASHER	24		
	5/8" UNC GR.8 NYLON INSERT LOCK NUT	12		
	7/8" UNC GR.8 HHCS X 7" LONG	2		
	7/8" GR.8 NARROW TYPE A WASHER	4		
MIO-M45VXFF017	Mounting Kit Installation/Operations Manual	1		
<p>Packed By : _____</p> <p>Tags : _____</p> <p>Customer : _____</p> <p>Date : _____</p> <p>Work order : _____</p> <p>Quantity : _____</p> <p>Legend: 1, 2, 3 = revision # C = Item Changed D = Item Deleted A = Item Added</p>				

Rafna Industries Ltd.				3-May-12
K-R45VXXR4531C Front Railgear Kit - Manual Axle Lock				rev. C
Vehicle Application Chart				
Year	Make	Model #	Model	
1999-Present	Ford	*4*	F-450 All Models	
1999-Present	Ford	*5*	F-550 All Models	
2008-Present	Ram	*4*	4500 All Models	
2008-Present	Ram	*5*	5500 All Models	
Part Number	Description	# Req.	Remarks	Check
R-4531AC	Vertical Front Railgear	1		
R-001	10" Wheel Assembly	2		
R-1000R	Rail Sweep Left Side	1		
R-1000L	Rail Sweep Right Side	1		
R-051	Side Wand Set	1		
R-2687AL	Front Bumper	1		
R-4699	Front Bumper Support	2		
R-4698	Collar	2		
S-001031	Railgear Operation Decal	1		
R-990KIT-204	Wheel Mounting Hardware	2		
R-990KIT-024	3/4" UNC Gr. 8 Bolt x 2.500" Long	8	Railgear Mounting	
	3/4" Gr. 8 Washer	16	Railgear Mounting	
	3/4" UNC Gr. 8 Nylon Insert Lock Nut	8	Railgear Mounting	
MI-R45VXXR4531C	Installation Manual	1		
MO-R45VXXR4531C	Operation, Service and Parts Manual	1		
<p>Packed By : _____</p> <p>Tags : _____</p> <p>Customer : _____</p> <p>Date : _____</p> <p>Work order : _____</p> <p>Quantity : _____</p> <p>Legend: 1, 2, 3 = revision # C = Item Changed D = Item Deleted A = Item Added</p>				

Rafna Industries Ltd.			4-Mar-20	
K-R45AVXFX005 Manual Front Axle Lock Kit			rev. B	
Vehicle Application Chart				
Year	Make	Model #	Model	
2017-Present	Ford	F-450/550	All 4X2 & 4X4 Models	
Part Number	Description	# Req.	Remarks	
R-12029D	L-Bracket Weldment Drivers Side	1		
R-12029P	L-Bracket Weldment Passengers Side	1		
R-5635	Insulator Washer	4		
R-4912-A	Hook	2		
R-12018	Spacer	2		
R-12031	Support Bracket	2		
R-4911	Bracket	2		
R-4914	Hook Catch	2		
R-6944	Rod Guide	2		
R-6947	Lock Tab	4		
R-6948A	Pull Rod	2		
R-12032	Washer, Fuel Cooler Spacer	1		
R-1650	Plate	2		
R-4686	Quick Release Pin	2		
-	SCREW, 0.375 X 4.000 HEX CAP Z/Y	2	USE HARDWARE KIT # R-990KIT-116A	
-	WASHER, SAE, 0.375	6		
-	NYLOCK NUT, UNC, 0.375	4		
-	WASHER, 0.500	8		
-	BOLT, UNC, 0.750 X 5.000 HEX CAP Z/Y	2		
-	BOLT, UNC, 0.750 X 5.500 HEX CAP Z/Y	2		
-	NYLOCK NUT, UNC, 0.500	2		
-	WASHER, 0.750	10		
-	NYLOCK NUT, UNC, 0.750	6		
-	WASHER, 0.250	2		
-	NYLOCK NUT, UNC, 0.250	2		
-	COTTER PIN, .1875 X 2.000	2		
MIO-R45AVXFX005	Installation Operations Manual	1		

<p>Legend:</p> <p>1, 2, 3 = revision #</p> <p>C = Item Changed</p> <p>D = Item Deleted</p> <p>A = Item Added</p>	<p>Packed By : _____</p> <p>Tags : _____</p> <p>Customer : _____</p> <p>Date : _____</p> <p>Work order : _____</p> <p>Quantity : _____</p>
------------------------------------------------------------------------------------------------------------------	--------------------------------------------------------------------------------------------------------------------------------------------

Rafna Industries Ltd.				10-Nov-17	
K-R46AVXF05 Manual Front Axle Lock Kit (Cable)				rev. B	
Vehicle Application Chart					
Year	Make	Model #	Model		
2017-Present	Ford	F-450/550	All 4X2 & 4X4 Models		
Part Number	Description	# Req.	Remarks	Check	
R-12029D	L-Bracket Weldment Drivers Side	1			
R-12029P	L-Bracket Weldment Passengers Side	1			
R-5635	Insulator Washer	4			
R-4912-A	Hook	2			
R-12018	Spacer	2			
R-12031	Support Bracket	2			
R-4911	Bracket	2			
R-4914	Hook Catch	2			
R-20319	Support Bracket, Pull Cable DS	1			
R-20319P	Support Bracket, Pull Cable PS	1			
R-20150	Clevis	2			
R-20143	Pin, Clevis	2			
R-12032	Washer, Fuel Cooler Spacer	1			
R-20320	Clevis Tab	2			
R-20325	Pull Cable Twist Lock, 90° Lng. 2" Trvl.	2			
P-00014	Bolt, Adaptor	2			
P-00018D	Mounting Bracket Pull Cable DS	1			
P-00018P	Mounting Bracket Pull Cable PS	1			
R-33285	Bumper Spacer	4			
990727-150-22	SCREW, 1/2" X 1 1/2" GR 8 H.H.C.S.	8			
990316-050-22	NUT, 1/2" GR 8 HEX NYLOCK Z/Y	8			
R-LABEL001	Pull to Unlock Placard	2			
990506-100-02	COTTER PIN, 0.125 X 1.000 Z/Y	2			
990600-050-002	WASHER, 0.500 Z/Y	18			
990310-050-22F	NUT, 0.500-20 GR 8 HEX JAM Z/Y	2			
-	NUT, NYLOCK, 0.500 UNC Z/Y	10	R-990KIT-277		
-	WASHER, FLAT, 0.500 TYPE-A Z/Y	20			
-	SCREW, 0.500 UNC X 3.500 HEX CAP Z/Y	8			
-	SCREW, 0.500 UNC X 3.250 HEX CAP Z/Y	2			
-	SCREW, 0.375 X 4.000 HEX CAP Z/Y	2			
-	WASHER, SAE, 0.375	6			
-	NYLOCK NUT, UNC, 0.375	4			
-	WASHER, 0.500	8			
-	BOLT, UNC, 0.750 X 5.000 HEX CAP Z/Y	2			
-	BOLT, UNC, 0.750 X 5.500 HEX CAP Z/Y	2			
-	NYLOCK NUT, UNC, 0.500	2	R-990KIT-116A		
-	WASHER, 0.750	10			
-	NYLOCK NUT, UNC, 0.750	6			
-	WASHER, 0.250	2			
-	NYLOCK NUT, UNC, 0.250	2			
-	COTTER PIN, .1875 X 2.000	2			
MIO-R46AVXF005	Installation Operations Manual	1			

Legend: 1, 2, 3 = revision # C = Item Changed D = Item Deleted A = Item Added	Packed By : _____ Tags : _____ Customer : _____ Date : _____ Work order : _____ Quantity : _____
--------------------------------------------------------------------------------------------------	-----------------------------------------------------------------------------------------------------------------

Rafna Industries Ltd.			30-Jan-18		
K-R45AVXF006 Hydraulic Front Axle Lock Kit			rev. B		
Vehicle Application Chart					
Year	Make	Model #	Model		
2017-PRESENT	Ford	F-450/550	All 4X2 & 4X4 Models		
Part Number	Description	# Req.	Remarks		
R-12029D	L-Bracket Weldment Drivers Side	1			
R-12029P	L-Bracket Weldment Passengers Side	1			
R-5635	Insulator Washer	4			
R-12018	Spacer	2			
R-12034D	Brkt Assy DS, Hydraulic Support	1			
R-12034P	Brkt Assy PS, Hydraulic Support	1			
R-4911	Bracket	2			
R-4914	Hook Catch	2			
R-12032	Washer, Fuel Cooler Spacer	1			
R-18072C	Cylinder, Lockup	2			
R-12035	Spacer, Cylinder	2			
R-12040	Clevis, Cylinder	2			
R-12041D	DS Hook, Hydraulic Axle Lockup	1			
R-12041P	PS Hook, Hydraulic Axle Lockup	1			
R-20161C	Fitting, 45 Elbow 1/4 JIC X 1/4 ORB	2			
R-20161A	Fitting, 90 Elbow 1/4 JIC X 1/4 ORB	2			
R-12043	RailGear Decal	1			
R-12043A	Axle Lock Decal	1			
-	SCREW, 0.375 X 4.000 HEX CAP Z/Y	2	USE HARDWARE KIT # R-990KIT-116AHYD		
-	WASHER, SAE, 0.375	13			
-	NYLOCK NUT, UNC, 0.375	5			
-	WASHER, 0.500	14			
-	BOLT, UNC, 0.750 X 5.000 HEX CAP Z/Y	2			
-	BOLT, UNC, 0.750 X 5.500 HEX CAP Z/Y	2			
-	NYLOCK NUT, UNC, 0.500	4			
-	WASHER, 0.750	10			
-	NYLOCK NUT, UNC, 0.750	6			
-	WASHER, 0.250	1			
-	NYLOCK NUT, UNC, 0.250	1			
-	BOLT, 0.500 X 2.250 HEX CAP Z/Y	2			
-	JAM NUT, UNF, 0.438	2			
MIO-R45AVXF006	Installation Operations Manual	1			
<table style="width:100%; border: none;"> <tr> <td style="width: 40%; vertical-align: top;"> <p>Legend: 1, 2, 3 = revision # C = Item Changed D = Item Deleted A = Item Added</p> </td> <td style="width: 60%; vertical-align: top;"> <p>Packed By : _____</p> <p>Tags : _____</p> <p>Customer : _____</p> <p>Date : _____</p> <p>Work order : _____</p> <p>Quantity : _____</p> </td> </tr> </table>				<p>Legend: 1, 2, 3 = revision # C = Item Changed D = Item Deleted A = Item Added</p>	<p>Packed By : _____</p> <p>Tags : _____</p> <p>Customer : _____</p> <p>Date : _____</p> <p>Work order : _____</p> <p>Quantity : _____</p>
<p>Legend: 1, 2, 3 = revision # C = Item Changed D = Item Deleted A = Item Added</p>	<p>Packed By : _____</p> <p>Tags : _____</p> <p>Customer : _____</p> <p>Date : _____</p> <p>Work order : _____</p> <p>Quantity : _____</p>				

Rafna Industries Ltd.				25-Apr-08
HR K-R45XRFR4836CBL Rear Railgear Kit				rev. 0
ORB Valves, Cable Lock-up, No brakes				
Vehicle Application Chart				
Year	Make	Model #	Model	
1999 - Present	Ford	*4*	F-450 All Models	
1999 - Present	Ford	*5*	F-550 All Models	
Part Number	Description	# Req.	Remarks	Check
R-4836G	Rotating Rear Railgear	1		
R-4837E	Axle Lock-Up	1		
R-001	10" Wheel Assembly	2		
R-4646R	Rail Sweep Right Side	1		
R-4646L	Rail Sweep Left Side	1		
R-4838	Push-Pull Cable	1		
S-001031	Railgear Operation Decal	1		
	"Pull To Unlock" Decal	1		
R-990KIT-204	Wheel Mounting Hardware	2		
	5/8" UNC Gr. 8 Bolt x 2.000" Long	6		
	5/8" Gr. 8 Washer	12		
R-990KIT-021	5/8" UNC Gr. 8 Nylon Insert Lock Nut	6	Railgear Mounting	
	3/4" UNC Gr. 8 Bolt x 2.25" Long	4		
	3/4" Gr. 8 Washer	8		
	3/4" UNC Gr. 8 Nylon Insert Lock Nut	4		
	Rear Lock-up Manual	1		
MI-R45XRFR4836	Installation Manual	1		
MO-R45XRFR4836	Operation, Service and Parts Manual	1		
<div style="display: flex; justify-content: space-between;"> <div style="width: 45%;"> <p>Legend: 1, 2, 3 = revision # C = Item Changed D = Item Deleted A = Item Added</p> </div> <div style="width: 50%;"> <p>Packed By : _____</p> <p>Tags : _____</p> <p>Customer : _____</p> <p>Date : _____</p> <p>Work order : _____</p> <p>Quantity : _____</p> </div> </div>				

Rafna Industries Ltd.				27-Aug-21
K-R45CBLBRZ Rear Railgear Kit				rev. A
ORB Valves, Cable Lock-up, No brakes, Bronze Bushings				
Vehicle Application Chart				
Year	Make	Model #	Model	
1999 - PRESENT	Ford	*4*	F-450 All Models	
1999 - PRESENT	Ford	*5*	F-550 All Models	
Part Number	Description	# Req.	Remarks	Check
R-4836GBRZ	Rotating Rear Railgear	1		
R-4837E	Axle Lock-Up	1		
R-001	10" Wheel Assembly	2		
R-4646R	Rail Sweep Right Side	1		
R-4646L	Rail Sweep Left Side	1		
R-4838	Push-Pull Cable	1		
S-001031	Railgear Operation Decal	1		
	"Pull To Unlock" Decal	1		
R-990KIT-204	Wheel Mounting Hardware	2		
	5/8" UNC Gr. 8 Bolt x 2.000" Long	6		
	5/8" Gr. 8 Washer	12		
R-990KIT-021	5/8" UNC Gr. 8 Nylon Insert Lock Nut	6	Railgear Mounting	
	3/4" UNC Gr. 8 Bolt x 2.25" Long	4		
	3/4" Gr. 8 Washer	8		
	3/4" UNC Gr. 8 Nylon Insert Lock Nut	4		
	Rear Lock-up Manual	1		
MI-R45XRFR4836	Installation Manual	1		
MO-R45XRFR4836	Operation, Service and Parts Manual	1		
<div style="display: flex; justify-content: space-between;"> <div style="width: 45%;"> <p>Legend: 1, 2, 3 = revision # C = Item Changed D = Item Deleted A = Item Added</p> </div> <div style="width: 50%;"> <p>Packed By : _____</p> <p>Tags : _____</p> <p>Customer : _____</p> <p>Date : _____</p> <p>Work order : _____</p> <p>Quantity : _____</p> </div> </div>				

Rafna Industries Ltd.				25-Apr-08
K-R45XRFR4836LVR Rear Railgear Kit				rev. 0
LEVER Lock-up, W/ Brakes				
Vehicle Application Chart				
Year	Make	Model #	Model	
1999-Present	Ford		F-450/550 All Models	
Part Number	Description	# Req.	Remarks	Check
R-4836G	Rotating Rear Railgear	1		
R-4837B	Axle Lock-Up	1		
K-R45XRFR4836	Lever Lock Up Kit	1		
R-001	10" Wheel Assembly Calgary	2		
R-4646R	Rail Sweep Right Side	1		
R-4646L	Rail Sweep Left Side	1		
S-001031	Railgear Operation Decal	1		
R-990KIT-204	Wheel Mounting Hardware	2		
R-990KIT-021	5/8" UNC Gr. 8 Bolt x 2.000" Long	6	Railgear Mounting	
	5/8" Gr. 8 Washer	12		
	5/8" UNC Gr. 8 Nylon Insert Lock Nut	6		
	3/4" UNC Gr. 8 Bolt x 2.25" Long	4		
	3/4" Gr. 8 Washer	8		
	3/4" UNC Gr. 8 Nylon Insert Lock Nut	4		
	Rear Lock-up Manual	1		
MI-R45XRFR4836	Installation Manual	1		
MO-R45XRFR4836	Operation, Service and Parts Manual	1		
<div style="display: flex; justify-content: space-between;"> <div style="width: 45%;"> <p>Legend:</p> <p>1, 2, 3 = revision #</p> <p>C = Item Changed</p> <p>D = Item Deleted</p> <p>A = Item Added</p> </div> <div style="width: 50%;"> <p>Packed By : _____</p> <p>Tags : _____</p> <p>Customer : _____</p> <p>Date : _____</p> <p>Work order : _____</p> <p>Quantity : _____</p> </div> </div>				

Rafna Industries Ltd.				27-Aug-21
K-R45LVRBRZ Rear Railgear Kit				rev. A
ORB Valves, Lever Lock-up, No brakes, Bronze Bushings				
Vehicle Application Chart				
Year	Make	Model #	Model	
1999-PRESENT	Ford		F-450/550 All Models	
Part Number	Description	# Req.	Remarks	Check
R-4836GBRZ	Rotating Rear Railgear	1		
R-4837B	Axle Lock-Up	1		
K-R45XRFR4836	Lever Lock Up Kit	1		
R-001	10" Wheel Assembly Calgary	2		
R-4646R	Rail Sweep Right Side	1		
R-4646L	Rail Sweep Left Side	1		
S-001031	Railgear Operation Decal	1		
R-990KIT-204	Wheel Mounting Hardware	2		
R-990KIT-021	5/8" UNC Gr. 8 Bolt x 2.000" Long	6	Railgear Mounting	
	5/8" Gr. 8 Washer	12		
	5/8" UNC Gr. 8 Nylon Insert Lock Nut	6		
	3/4" UNC Gr. 8 Bolt x 2.25" Long	4		
	3/4" Gr. 8 Washer	8		
	3/4" UNC Gr. 8 Nylon Insert Lock Nut	4		
	Rear Lock-up Manual	1		
MI-R45XRFR4836	Installation Manual	1		
MO-R45XRFR4836	Operation, Service and Parts Manual	1		
<div style="display: flex; justify-content: space-between;"> <div style="width: 45%;"> <p>Legend:</p> <p>1, 2, 3 = revision #</p> <p>C = Item Changed</p> <p>D = Item Deleted</p> <p>A = Item Added</p> </div> <div style="width: 50%;"> <p>Packed By : _____</p> <p>Tags : _____</p> <p>Customer : _____</p> <p>Date : _____</p> <p>Work order : _____</p> <p>Quantity : _____</p> </div> </div>				

Rafna Industries Ltd.				6-Mar-20
HR K-H45VRF004 Hydraulic Kit w/ Pump - Manual Axle Lock				rev. E
Vehicle Application Chart				
Year	Make	Model #	Model	
1999 +	Ford	*4*	F-450 All Models	
1999 +	Ford	*5*	F-550 All Models	
Part Number	Description	# Req.	Remarks	Check
R-060	Railgear Hydraulic Pump	1		
R-19048	Control Mounting Plate	2		
R-2837	Pump Mounting Bracket	1		
CO-106	Dash Switch	1		
R-1577	5 Amp In-Line Fuse Connector	1		
R-1577-1	5 Amp Automotive Fuse	1		
CO-130G	"Railgear Pump" Decal	1		
H-990KIT-011	Hydraulic Fitting	4	HY-848FSO-04-06	
	Hydraulic Fitting	2	844FS-04-04	
	Hydraulic Hose 20" Long	2	HFS2-04-020A	
	Hydraulic Hose 33" Long	2	HFS2-04-033A	
	Hydraulic Hose 32" Long	2	HFS2-04-032A	
R-990KIT-023	Hydraulic Hose 360" Long	2	HFS2-04-360B	
	3/8" UNC Gr. 8 Bolt x 1" Long	2	Installed on Pump	
	3/8" SAE Washer	2	Installed on Pump	
	3/8" Lock Washer	2	Pump	
MIO-H45VRF004	Installation and Operation. Manual	1		
MO-R45XXXXR060EMY	Emergency Hand Pump Operations Manual	1		
<p>Legend:</p> <p>1, 2, 3 = revision #</p> <p>C = Item Changed</p> <p>D = Item Deleted</p> <p>A = Item Added</p> <p>Packed By : _____</p> <p>Tags : _____</p> <p>Customer : _____</p> <p>Date : _____</p> <p>Work order : _____</p> <p>Quantity : _____</p> <p>Pump S/N: _____</p>				

Rafna Industries Ltd.				5-Sep-08
K-H45VRF005 Hydraulic Kit w/o Pump - Manual Axle Lock				rev. C
Vehicle Application Chart				
Year	Make	Model #	Model	
1999 - Present	Ford	*4*	F-450 All Models	
1999 - Present	Ford	*5*	F-550 All Models	
2008 - Present	Dodge		4500 Chassis Cab	
2008 - Present	Dodge		5500 Chassis Cab	
Part Number	Description	# Req.	Remarks	Check
S-802020	Operating Valve	2		
R-1013	Operating Valve Mounting Plate	2		
R-2407	Operating Valve Bracket	1		
HY-849FSO-04-06	Hydraulic Fitting	2	Installed On Operating Valve	
HY-844FS-04-04	Hydraulic Fitting	2		
HY-HU04-04NJ	Hydraulic Coupling	12	Installed on Hoses	
HY-HFS2-04 x 12"	Hydraulic Hose 12" Long	2	HU-04-04NJ Both Ends	
HY-HFS2-04 x 20"	Hydraulic Hose 20" Long	2	HU-04-04NJ Both Ends	
HY-HFS2-04 x 33"	Hydraulic Hose 33" Long	2	HU-04-04NJ Both Ends	
-	1/4" UNC Gr. 8 Bolt x 2.25" Long	4		
-	1/4" SAE Washer	8		
-	1/4" UNC Gr. 3 Nylock Nut	4		
MI-H45VRF005	Installation Manual	1		
MO-H45VRF005	Operation, Service and Parts Manual	1		
<p>Legend:</p> <p>1, 2, 3 = revision #</p> <p>C = Item Changed</p> <p>D = Item Deleted</p> <p>A = Item Added</p> <p>Packed By : _____</p> <p>Tags : _____</p> <p>Customer : _____</p> <p>Date : _____</p> <p>Work order : _____</p> <p>Quantity : _____</p>				

Rafna Industries Ltd.				02/12/20
K-B45VXXR4697 Front Hydraulic Brake Kit				rev. 9
Vehicle Application Chart				
Year	Make	Model #	Model	
1999-PRESENT	Ford	*4*	F-450 All Models	
1999-PRESENT	Ford	*5*	F-550 All Models	
Part Number	Description	# Req.	Remarks	Check
R-4570D	Hydraulic Brake (Left Side)	1	MTG HDW INCLUDED	
R-4570P	Hydraulic Brake (Right Side)	1	MTG HDW INCLUDED	
R-1577	In-Line Fuse Connector	1		
R-1577-1	5A In-Line Fuse	1		
R-5670	Hydraulic Brake Pump	1		
R-4574A	Hydraulic Brake Pump Bracket	1		
R-5692	Electric Brake Control	1		
CO-106	Pilot Switch, Red	1		
CO-130H	"Railgear Brake Pump" Decal	1		
H-990KIT-002	Hydraulic Fitting 1/4 JIC "T"	1	844FS-04-04	
	Hydraulic Hose 24" Long	1	HY-HFS2-04-024A	
	Hydraulic Hose 38" Long	1	HY-HFS2-04-038A	
	Hydraulic Hose 51" Long	1	HY-HFS2-04-051A	
R-990KIT-025	1/4" UNC Gr. 8 Bolt x 0.75" Long	3	Pump	
	1/4" SAE Washer	3	Pump	
	1/4" Lock Washer	3	Pump	
MIO-B45VXX4697	Installation Manual	1		
	Operation, Service and Parts Manual	1		
Packed By : _____ Tags : _____ Customer : _____ Date : _____ Work order : _____ Quantity : _____				

Rafna Industries Ltd.				18-Feb-20
K-B45XRFR4899 Rear Hydraulic Brake Kit				rev. 10
Vehicle Application Chart				
Year	Make	Model #	Model	
1999 +	Ford	*4*	F-450 All Models	
1999 +	Ford	*5*	F-550 All Models	
Part Number	Description	# Req.	Remarks	Check
K-B45XRFR4899 Rear Hydraulic Brake Kit				
R-4897D	Hydraulic Brake Driver's Side	1		
R-4897P	Hydraulic Brake Passenger's Side	1		
H-990KIT-010	Hydraulic Fitting	1	HY-719-FSC-06-04	
	Hydraulic Fitting	1	HY-845FSC-04-04	
	Hydraulic Fitting	1	HY-844FS-04-04	
	Hydraulic Hose 33" Long	1	HFS2-04-033C	
	Hydraulic Hose 65" Long	1	HFS2-04-065B	
	Hydraulic Hose 360" Long	1	HFS2-04-360A	
R-990KIT-457 (QTY 2X)	Screw, 0.500 X 2.250 Hex Cap Z/Y	6	HDW to Mount Brakes to Axle	
	Washer, 0.500 Type A Narrow Flat Z/Y	12		
	Nut, 0.500 Reg Hex Nylon Insert Lock Z/Y	6		
MIO-B45VXX4697	Brake Installation/Operations Manual	1		
Legend: 1, 2, 3 = revision # C = Item Changed D = Item Deleted A = Item Added				

Rafna Industries Ltd.				14-Jan-16
K- SXXXXX004450 Steering Wheel Lock Kit (Hook & Loop)				rev. A
Vehicle Application Chart				
Part Number	Description	# Req.	Remarks	Check
K-SXXXXX004	Seering Wheel Lock Kit	1		
R-21164	Sticker, Max. Recommended Speed	1		
MIO-SXXXXX004450	Sticker, Max. Recommended Speed	1		

Rafna Industries Ltd.				26-Apr-12		
K-H46EMG001 EMERGENCY PUMP KIT				rev. A		
1/4" HOSE CONNECTIONS						
Rotary R-460/R-450						
Vehicle Application Chart						
Year	Make	Model #	Model			
Part Number	Description	# Req.	Remarks	Check		
R-8594	Ball Valve	2				
R-23200	4-Way Cross Connector 1/4" JIC	4				
R-23204	1/4" Quick Connect Plug	4				
R-23202	1/4" Quick Connect Coupler	2				
R-23206	1/4" Dust Cap	4				
R-23208	1/4" Dust Plug	2				
R-056	Emergency Hand Pump	1				
<table style="width: 100%; border: none;"> <tr> <td style="width: 40%; vertical-align: top;"> <p>Legend:</p> <p>1, 2, 3 = revision #</p> <p>C = Item Changed</p> <p>D = Item Deleted</p> <p>A = Item Added</p> </td> <td style="width: 60%; vertical-align: top;"> <p>Packed By : _____</p> <p>Tags : _____</p> <p>Customer : _____</p> <p>Date : _____</p> <p>Work order : _____</p> <p>Quantity : _____</p> </td> </tr> </table>					<p>Legend:</p> <p>1, 2, 3 = revision #</p> <p>C = Item Changed</p> <p>D = Item Deleted</p> <p>A = Item Added</p>	<p>Packed By : _____</p> <p>Tags : _____</p> <p>Customer : _____</p> <p>Date : _____</p> <p>Work order : _____</p> <p>Quantity : _____</p>
<p>Legend:</p> <p>1, 2, 3 = revision #</p> <p>C = Item Changed</p> <p>D = Item Deleted</p> <p>A = Item Added</p>	<p>Packed By : _____</p> <p>Tags : _____</p> <p>Customer : _____</p> <p>Date : _____</p> <p>Work order : _____</p> <p>Quantity : _____</p>					

Rafna Industries Ltd.				26-Apr-12
K-H46EMG002 EMERGENCY PUMP KIT				rev. A
3/8" HOSE CONNECTIONS				
Rotary R-460/R-450				
Vehicle Application Chart				
Year	Make	Model #	Model	
Part Number	Description	# Req.	Remarks	Check
R-8594	Ball Valve	2		
R-23201	4-Way Cross Connector 3/8" JIC	4		
R-23205	3/8" Quick Connect Plug	4		
R-23203	3/8" Quick Connect Coupler	2		
R-23207	3/8" Dust Cap	4		
R-23209	3/8" Dust Plug	2		
R-056	Emergency Hand Pump	1		
<div style="display: flex; justify-content: space-between;"> <div style="width: 45%;"> <p>Legend:</p> <p>1, 2, 3 = revision #</p> <p>C = Item Changed</p> <p>D = Item Deleted</p> <p>A = Item Added</p> </div> <div style="width: 50%;"> <p>Packed By : _____</p> <p>Tags : _____</p> <p>Customer : _____</p> <p>Date : _____</p> <p>Work order : _____</p> <p>Quantity : _____</p> </div> </div>				

Rafna Industries Ltd.				10-Feb-16
K-R45VFML10700				8-Jan-20
R-450VF MECHANICAL LOCK				rev. B
Vehicle Application Chart				
Year	Make	Model #	Model	
ALL	ALL		ALL	
Part Number	Description	# Req.	Remarks	Check
R-10701	HITCH PIN	2		
R-10702	CLAMP HALF	2		
R-10706	CLAMP HALF WITH HOLDER	2		
R-10707	TETHER	2		
R-10708	SPLIT RING	2		
R-10709	HAIRPIN CLIP	2		
R-10900	DECAL "PIN GUIDE TUBES"	2		
R-990KIT-418	H.H.C.S., 3/8" UNC X 1-1/4"	2	HARDWARE KIT	
	LOCK WASHER, 3/8"	2		
	HEX NUT, 3/8" UNC	2		

